

MATLAB[®]

The Language of Technical Computing

- Computation
- Visualization
- Programming

External Interfaces

Version 7



How to Contact The MathWorks:



www.mathworks.com	Web
comp.soft-sys.matlab	Newsgroup



support@mathworks.com	Technical support
suggest@mathworks.com	Product enhancement suggestions
bugs@mathworks.com	Bug reports
doc@mathworks.com	Documentation error reports
service@mathworks.com	Order status, license renewals, passcodes
info@mathworks.com	Sales, pricing, and general information



508-647-7000	Phone
--------------	-------



508-647-7001	Fax
--------------	-----



The MathWorks, Inc. 3 Apple Hill Drive Natick, MA 01760-2098	Mail
--	------

For contact information about worldwide offices, see the MathWorks Web site.

MATLAB External Interfaces

© COPYRIGHT 1984 - 2004 by The MathWorks, Inc.

The software described in this document is furnished under a license agreement. The software may be used or copied only under the terms of the license agreement. No part of this manual may be photocopied or reproduced in any form without prior written consent from The MathWorks, Inc.

FEDERAL ACQUISITION: This provision applies to all acquisitions of the Program and Documentation by, for, or through the federal government of the United States. By accepting delivery of the Program or Documentation, the government hereby agrees that this software or documentation qualifies as commercial computer software or commercial computer software documentation as such terms are used or defined in FAR 12.212, DFARS Part 227.72, and DFARS 252.227-7014. Accordingly, the terms and conditions of this Agreement and only those rights specified in this Agreement, shall pertain to and govern the use, modification, reproduction, release, performance, display, and disclosure of the Program and Documentation by the federal government (or other entity acquiring for or through the federal government) and shall supersede any conflicting contractual terms or conditions. If this License fails to meet the government's needs or is inconsistent in any respect with federal procurement law, the government agrees to return the Program and Documentation, unused, to The MathWorks, Inc.

MATLAB, Simulink, Stateflow, Handle Graphics, and Real-Time Workshop are registered trademarks, and TargetBox is a trademark of The MathWorks, Inc.

Other product or brand names are trademarks or registered trademarks of their respective holders.

Printing History:	December 1996	First printing	New for MATLAB 5 (Release 8)
	July 1997	Online only	Revised for MATLAB 5.1 (Release 9)
	January 1998	Second printing	Revised for MATLAB 5.2 (Release 10)
	October 1998	Third printing	Revised for MATLAB 5.3 (Release 11)
	November 2000	Fourth printing	Revised and renamed for MATLAB 6.0 (Release 12)
	June 2001	Online only	Revised for MATLAB 6.1 (Release 12.1)
	July 2002	Online only	Revised for MATLAB 6.5 (Release 13)
	January 2003	Online only	Revised for MATLAB 6.5.1 (Release 13SP1)
	June 2004	Online only	Revised for MATLAB 7.0 (Release 14)
	October 2004	Online only	Revised for MATLAB 7.0.1 (Release 14SP1)

Importing and Exporting Data

1

Using MAT-Files	1-2
Importing Data to MATLAB	1-2
Exporting Data from MATLAB	1-3
Exchanging Data Files Between Platforms	1-4
Reading and Writing MAT-Files	1-5
Writing Character Data	1-8
Finding Associated Files	1-9
Examples of MAT-Files	1-12
Creating a MAT-File in C	1-12
Reading a MAT-File in C	1-17
Creating a MAT-File in Fortran	1-21
Reading a MAT-File in Fortran	1-26
Compiling and Linking MAT-File Programs	1-30
Masking Floating Point Exceptions	1-30
Compiling and Linking on UNIX	1-31
Compiling and Linking on Windows	1-33
Required Files from Third-Party Sources	1-33
Working Directly with Unicode	1-35

MATLAB Interface to Generic DLLs

2

Overview	2-2
Loading and Unloading the Library	2-3
Loading the Library	2-3
Unloading the Library	2-3
Getting Information About the Library	2-4

Invoking Library Functions	2-7
Passing Arguments	2-8
Some General Rules	2-9
Passing References	2-10
Data Conversion	2-11
Primitive Types	2-11
Enumerated Types	2-15
Structures	2-15
Creating References	2-21
Reference Pointers	2-25

Calling C and Fortran Programs from MATLAB

3

Introducing MEX-Files	3-2
Using MEX-Files	3-2
The Distinction Between mx and mex Prefixes	3-3
MATLAB Data	3-4
The MATLAB Array	3-4
Data Storage	3-4
Data Types in MATLAB	3-5
Sparse Matrices	3-7
Using Data Types	3-7
Building MEX-Files	3-9
Compiler Requirements	3-9
Testing Your Configuration on UNIX	3-10
Testing Your Configuration on Windows	3-12
Specifying an Options File	3-15
Custom Building MEX-Files	3-18
Who Should Read this Chapter	3-18
MEX Script Switches	3-18
Default Options File on UNIX	3-20

Default Options File on Windows	3-21
Custom Building on UNIX	3-22
Custom Building on Windows	3-24
Troubleshooting	3-28
Configuration Issues	3-28
Understanding MEX-File Problems	3-30
Compiler and Platform-Specific Issues	3-33
Memory Management Compatibility Issues	3-33
Additional Information	3-38
Files and Directories - UNIX Systems	3-38
Files and Directories - Windows Systems	3-41
Examples	3-43
Technical Support	3-44

Creating C Language MEX-Files

4

C MEX-Files	4-2
The Components of a C MEX-File	4-2
Required Arguments to a MEX-File	4-4
Examples of C MEX-Files	4-6
A First Example — Passing a Scalar	4-7
Passing Strings	4-10
Passing Two or More Inputs or Outputs	4-13
Passing Structures and Cell Arrays	4-16
Handling Complex Data	4-20
Handling 8-,16-, and 32-Bit Data	4-23
Manipulating Multidimensional Numerical Arrays	4-25
Handling Sparse Arrays	4-29
Calling Functions from C MEX-Files	4-33
Advanced Topics	4-36
Help Files	4-36
Linking Multiple Files	4-36

Workspace for MEX-File Functions	4-37
Memory Management	4-37
Large File I/O	4-40
Using LAPACK and BLAS Functions	4-45
Debugging C Language MEX-Files	4-53
Debugging on UNIX	4-53
Debugging on Windows	4-54

Creating Fortran MEX-Files

5

Fortran MEX-Files	5-2
The Components of a Fortran MEX-File	5-2
The %val Construct	5-7
Examples of Fortran MEX-Files	5-8
A First Example — Passing a Scalar	5-9
Passing Strings	5-11
Passing Arrays of Strings	5-13
Passing Matrices	5-15
Passing Two or More Inputs or Outputs	5-18
Handling Complex Data	5-21
Dynamically Allocating Memory	5-24
Handling Sparse Matrices	5-26
Calling Functions from Fortran MEX-Files	5-30
Advanced Topics	5-34
Help Files	5-34
Linking Multiple Files	5-34
Workspace for MEX-File Functions	5-34
Memory Management	5-35
Debugging Fortran Language MEX-Files	5-36
Debugging on UNIX	5-36
Debugging on Windows	5-37

Calling MATLAB from C and Fortran Programs

6

Using the MATLAB Engine	6-2
The Engine Library	6-2
GUI-Intensive Applications	6-4
Examples of Calling Engine Functions	6-5
Calling MATLAB from a C Application	6-5
Calling MATLAB from a Fortran Application	6-10
Attaching to an Existing MATLAB Session	6-14
Compiling and Linking Engine Programs	6-16
Masking Floating-Point Exceptions	6-16
Compiling and Linking on UNIX	6-17
Compiling and Linking on Windows	6-19
Required Files from Third-Party Sources	6-19
Working Directly with Unicode	6-21

Calling Java from MATLAB

7

Using Java from MATLAB: An Overview	7-2
Java Interface Is Integral to MATLAB	7-2
Benefits of the MATLAB Java Interface	7-2
Who Should Use the MATLAB Java Interface	7-2
To Learn More About Java Programming	7-3
Platform Support for the Java Virtual Machine	7-3
Using a Different Version of the Java JVM	7-3
Bringing Java Classes and Methods into MATLAB	7-6
Sources of Java Classes	7-6
Defining New Java Classes	7-7
The Java Class Path	7-7
Making Java Classes Available to MATLAB	7-9
Loading Java Class Definitions	7-11

Simplifying Java Class Names	7-12
Locating Native Method Libraries	7-13
Creating and Using Java Objects	7-14
Constructing Java Objects	7-14
Concatenating Java Objects	7-16
Saving and Loading Java Objects to MAT-Files	7-18
Finding the Public Data Fields of an Object	7-19
Accessing Private and Public Data	7-20
Determining the Class of an Object	7-22
Invoking Methods on Java Objects	7-23
Using Java and MATLAB Calling Syntax	7-23
Invoking Static Methods on Java Classes	7-25
Obtaining Information About Methods	7-26
Java Methods That Affect MATLAB Commands	7-30
How MATLAB Handles Undefined Methods	7-31
How MATLAB Handles Java Exceptions	7-32
Working with Java Arrays	7-33
How MATLAB Represents the Java Array	7-34
Creating an Array of Objects Within MATLAB	7-38
Accessing Elements of a Java Array	7-40
Assigning to a Java Array	7-43
Concatenating Java Arrays	7-47
Creating a New Array Reference	7-48
Creating a Copy of a Java Array	7-49
Passing Data to a Java Method	7-51
Conversion of MATLAB Argument Data	7-51
Passing Built-In Data Types	7-53
Passing String Arguments	7-54
Passing Java Objects	7-55
Other Data Conversion Topics	7-58
Passing Data to Overloaded Methods	7-59
Handling Data Returned from a Java Method	7-61
Conversion of Java Return Data	7-61
Built-In Data Types	7-62

Java Objects	7-62
Converting Objects to MATLAB Data Types	7-62
Introduction to Programming Examples	7-67
Example – Reading a URL	7-68
Description of URLdemo	7-68
Running the Example	7-69
Example – Finding an Internet Protocol Address	7-71
Description of resolveip	7-71
Running the Example	7-72
Example – Communicating Through a Serial Port	7-73
Description of Serial Example	7-74
Running the serialexample Program	7-77
Example – Creating and Using a Phone Book	7-78
Description of Function phonebook	7-79
Description of Function pb_lookup	7-83
Description of Function pb_add	7-84
Description of Function pb_remove	7-85
Description of Function pb_change	7-85
Description of Function pb_listall	7-87
Description of Function pb_display	7-87
Description of Function pb_keyfilter	7-88
Running the phonebook Program	7-88

COM and DDE Support (Windows Only)

8

Introducing MATLAB COM Integration	8-2
Concepts and Terminology	8-2
Supported Client/Server Configurations	8-4
Registering Controls and Servers	8-8

MATLAB COM Client Support	8-10
Creating the Server Process — an Overview	8-10
Creating an ActiveX Control	8-12
Instantiating a DLL Component	8-18
Instantiating an EXE Component	8-18
Getting Interfaces to the Object	8-19
Invoking Commands on a COM Object	8-22
Identifying Objects and Interfaces	8-26
Invoking Methods	8-27
Object Properties	8-33
Control and Server Events	8-43
Writing Event Handlers	8-52
Saving Your Work	8-58
Releasing COM Interfaces and Objects	8-59
Identifying Objects	8-59
Examples of MATLAB as an Automation Client	8-61
Additional COM Client Information	8-66
Using COM Collections	8-66
Converting Data	8-67
Using MATLAB as a DCOM Client	8-69
MATLAB COM Support Limitations	8-69
MATLAB Automation Server Support	8-70
Creating the Automation Server	8-70
Connecting to an Existing Server	8-71
Automation Server Functions	8-72
Example — Running an M-File from Visual Basic	8-76
Example — Viewing Methods from a Visual Basic Client	8-77
MATLAB Automation Properties	8-77
Additional Automation Server Information	8-79
Creating the Server Manually	8-79
Specifying a Shared or Dedicated Server	8-79
Using MATLAB as a DCOM Server	8-80
Dynamic Data Exchange (DDE)	8-81
DDE Concepts and Terminology	8-81
Accessing MATLAB as a Server	8-83
The DDE Name Hierarchy	8-84

Example — Using Visual Basic and the MATLAB DDE Server	8-88
Using MATLAB as a Client	8-90
Example — Importing Data From an Excel Application	8-91
DDE Advisory Links	8-92

Using Web Services in MATLAB

9

What Are Web Services in MATLAB?	96
Understanding Data Type Conversions	98
Finding More Information About Web Services	99
 Using Web Services in MATLAB	 100
 Building MATLAB Applications with Web Services	 104
Understanding Web Service Limitations	104
Programming with Web Services	104
Simple M Code Example	105

Serial Port I/O

10

Introduction	9-3
What Is the MATLAB Serial Port Interface?	9-3
Supported Serial Port Interface Standards	9-3
Supported Platforms	9-3
Using the Examples with Your Device	9-4
 Overview of the Serial Port	 9-5
What Is Serial Communication?	9-5
The Serial Port Interface Standard	9-5
Connecting Two Devices with a Serial Cable	9-6
Serial Port Signals and Pin Assignments	9-7

Serial Data Format	9-12
Finding Serial Port Information for Your Platform	9-16
Selected Bibliography	9-18
Getting Started with Serial I/O	9-19
Example: Getting Started	9-19
The Serial Port Session	9-20
Configuring and Returning Properties	9-21
Creating a Serial Port Object	9-25
Configuring Properties During Object Creation	9-26
The Serial Port Object Display	9-26
Creating an Array of Serial Port Objects	9-27
Connecting to the Device	9-28
Configuring Communication Settings	9-29
Writing and Reading Data	9-30
Example: Introduction to Writing and Reading Data	9-30
Controlling Access to the MATLAB Command Line	9-30
Writing Data	9-32
Reading Data	9-37
Example: Writing and Reading Text Data	9-44
Example: Parsing Input Data Using <code>stread</code>	9-45
Example: Reading Binary Data	9-46
Events and Callbacks	9-50
Example: Introduction to Events and Callbacks	9-50
Event Types and Callback Properties	9-51
Storing Event Information	9-52
Creating and Executing Callback Functions	9-54
Enabling Callback Functions After They Error	9-55
Example: Using Events and Callbacks	9-56
Using Control Pins	9-58
Signaling the Presence of Connected Devices	9-58
Controlling the Flow of Data: Handshaking	9-61

Debugging: Recording Information to Disk	9-64
Example: Introduction to Recording Information	9-64
Creating Multiple Record Files	9-65
Specifying a Filename	9-65
The Record File Format	9-66
Example: Recording Information to Disk	9-67
Saving and Loading	9-70
Using Serial Port Objects on Different Platforms	9-70
Disconnecting and Cleaning Up	9-71
Disconnecting a Serial Port Object	9-71
Cleaning Up the MATLAB Environment	9-71
Property Reference	9-72
The Property Reference Page Format	9-72
Serial Port Object Properties	9-73

Index

Importing and Exporting Data

Using MAT-Files (p. 1-2)

Examples of MAT-Files (p. 1-12)

Compiling and Linking MAT-File
Programs (p. 1-30)

Methods of importing and exporting MATLAB® data, and
MAT-file routines that enable you to do this

Programs to create and read a MAT-file in C and Fortran

Compiling and linking on Windows and UNIX

Using MAT-Files

This section describes the various techniques for importing data to and exporting data from the MATLAB environment. The main topics that are discussed are:

- “Importing Data to MATLAB” on page 1-2
- “Exporting Data from MATLAB” on page 1-3
- “Exchanging Data Files Between Platforms” on page 1-4
- “Reading and Writing MAT-Files” on page 1-5
- “Writing Character Data” on page 1-8
- “Finding Associated Files” on page 1-9

The most important approach to importing and exporting data involves the use of MAT-files, the data file format that MATLAB uses for saving data to your disk. MAT-files provide a convenient mechanism for moving your MATLAB data between different platforms and for importing and exporting your data to other stand-alone MATLAB applications.

To simplify your use of MAT-files in applications outside of MATLAB, we have developed a library of access routines with a `mat` prefix that you can use in your own C or Fortran programs to read and write MAT-files. Programs that access MAT-files also use the `mx` prefixed API routines discussed in Chapter 4, “Creating C Language MEX-Files” and Chapter 5, “Creating Fortran MEX-Files.”

Importing Data to MATLAB

You can introduce data from other programs into MATLAB by several methods. The best method for importing data depends on how much data there is, whether the data is already in machine-readable form, and what format the data is in. Here are some choices. Select the one that best meets your needs.

- **Enter the data as an explicit list of elements.**

If you have a small amount of data, less than 10-15 elements, it is easy to type the data explicitly using brackets `[]`. This method is awkward for larger amounts of data because you can't edit your input if you make a mistake.

- **Create data in an M-file.**

Use your text editor to create an M-file that enters your data as an explicit list of elements. This method is useful when the data isn't already in computer-readable form and you have to type it in. Essentially the same as the first method, this method has the advantage of allowing you to use your editor to change the data and correct mistakes. You can then just rerun your M-file to re-enter the data.

- **Load data from an ASCII flat file.**

A *flat file* stores the data in ASCII form, with fixed-length rows terminated with new lines (carriage returns) and with spaces separating the numbers. You can edit ASCII flat files using a normal text editor. Flat files can be read directly into MATLAB using the `load` command. The result is to create a variable with the same name as the filename.

See the `load` function reference page for more information.

- **Read data using MATLAB I/O functions.**

You can read data using `fopen`, `fread`, and MATLAB other low-level I/O functions. This method is useful for loading data files from other applications that have their own established file formats.

- **Write a MEX-file to read the data.**

This is the method of choice if subroutines are already available for reading data files from other applications. See the section, "Introducing MEX-Files" on page 3-2, for more information.

- **Write a program to translate your data.**

You can write a program in C or Fortran to translate your data into MAT-file format. You can then read the MAT-file into MATLAB using the `load` command. Refer to the section, "Reading and Writing MAT-Files" on page 1-5, for more information.

Exporting Data from MATLAB

There are several methods for getting MATLAB data back to the outside world:

- **Create a diary file.**

For small matrices, use the `diary` command to create a diary file and display the variables, echoing them into this file. You can use your text editor to manipulate the diary file at a later time. The output of `diary` includes the

MATLAB commands used during the session, which is useful for inclusion into documents and reports.

- **Use the Save command.**

Save the data in ASCII form using the save command with the `-ascii` option. For example,

```
A = rand(4,3);  
save temp.dat A -ascii  
creates an ASCII file called temp.dat containing  
1.3889088e-001 2.7218792e-001 4.4509643e-001  
2.0276522e-001 1.9881427e-001 9.3181458e-001  
1.9872174e-001 1.5273927e-002 4.6599434e-001  
6.0379248e-001 7.4678568e-001 4.1864947e-001
```

The `-ascii` option supports two-dimensional double and character arrays only. Multidimensional arrays, cell arrays, and structures are not supported. See the save function reference page for more information.

- **Use MATLAB I/O functions.**

Write the data in a special format using `fopen`, `fwrite`, and the other low-level I/O functions. This method is useful for writing data files in the file formats required by other applications.

- **Develop a MEX-file to write the data.**

You can develop a MEX-file to write the data. This is the method of choice if subroutines are already available for writing data files in the form needed by other applications. See the section, “Introducing MEX-Files” on page 3-2, for more information.

- **Translate data from a MAT-file.**

You can write out the data as a MAT-file using the save command. You can then write a program in C or Fortran to translate the MAT-file into your own special format. See the section, “Reading and Writing MAT-Files” on page 1-5, for more information.

Exchanging Data Files Between Platforms

You may want to work with MATLAB implementations on several different computer systems, or need to transmit MATLAB applications to users on other

systems. MATLAB applications consist of M-files containing functions and scripts, and MAT-files containing binary data.

Both types of files can be transported directly between machines: M-files because they are platform independent and MAT-files because they contain a machine signature in the file header. MATLAB checks the signature when it loads a file and, if a signature indicates that a file is foreign, performs the necessary conversion.

Using MATLAB across several different machine architectures requires a facility for exchanging both binary and ASCII data between the various machines. Examples of this type of facility include FTP, NFS, Kermit, and other communication programs. When using these programs, be careful to transmit binary MAT-files in *binary file mode* and ASCII M-files in *ASCII file mode*. Failure to set these modes correctly corrupts the data.

Reading and Writing MAT-Files

The save command in MATLAB saves the MATLAB arrays currently in memory to a binary disk file called a MAT-file. The term MAT-file is used because these files have the extension `.mat`. The load command performs the reverse operation. It reads the MATLAB arrays from a MAT-file on disk back into MATLAB workspace.

A MAT-file may contain one or more of any of the data types supported in MATLAB 5 or later, including strings, matrices, multidimensional arrays, structures, and cell arrays. MATLAB writes the data sequentially onto disk as a continuous byte stream.

MAT-File Interface Library

The MAT-file interface library contains a set of routines for reading and writing MAT-files. You can call these routines from within your own C and Fortran programs. We recommend that you use these routines, rather than attempt to write your own code, to perform these operations. By using the routines in this library, you will be insulated from future changes to the MAT-file structure.

The MAT-file library contains routines for reading and writing MAT-files. They all begin with the three-letter prefix `mat`. These tables list all the available MAT-functions and their purposes.

Table 1-1: C MAT-File Routines

MAT-Function	Purpose
<code>matOpen</code>	Open a MAT-file
<code>matClose</code>	Close a MAT-file
<code>matGetDir</code>	Get a list of MATLAB arrays from a MAT-file
<code>matGetFp</code>	Get an ANSI C file pointer to a MAT-file
<code>matGetVariable</code>	Read a MATLAB array from a MAT-file
<code>matPutVariable</code>	Write a MATLAB array to a MAT-file
<code>matGetNextVariable</code>	Read the next MATLAB array from a MAT-file
<code>matDeleteVariable</code>	Remove a MATLAB array from a MAT-file
<code>matPutVariableAsGlobal</code>	Put a MATLAB array into a MAT-file such that the load command will place it into the global workspace
<code>matGetVariableInfo</code>	Load a MATLAB array header from a MAT-file (no data)
<code>matGetNextVariableInfo</code>	Load the next MATLAB array header from a MAT-file (no data)

Table 1-2: Fortran MAT-File Routines

MAT-Function	Purpose
matOpen	Open a MAT-file
matClose	Close a MAT-file
matGetDir	Get a list of MATLAB arrays from a MAT-file
matGetVariable	Get a named MATLAB array from a MAT-file
matGetVariableInfo	Get header for named MATLAB array from a MAT-file
matPutVariable	Put a MATLAB array into a MAT-file
matPutVariableAsGlobal	Put a MATLAB array into a MAT-file
matGetNextVariable	Get the next sequential MATLAB array from a MAT-file
matGetNextVariableInfo	Get header for next sequential MATLAB array from a MAT-file
matDeleteVariable	Remove a MATLAB array from a MAT-file

Writing Character Data

MATLAB writes character data to MAT-files using Unicode character encoding by default. You can override this setting and use the default character set for your system instead by doing one of the following:

- From the MATLAB command line or a MATLAB function, save your data to the MAT-file using the command `save -nounicode`
- From a C mex file, open the MAT-file you will write the data to using the command `matOpen -wL`

See the individual reference pages for these functions for more information.

You can override this setting for all of your MATLAB sessions using the **Preferences** dialog box. Open the **Preferences** dialog and select **General** and then **MAT-Files**. Click on **Unicode** or **Local Character Set**. See “General Preferences for MATLAB” in the Desktop Tools and Development Environment documentation for more information.

Note Level 4 MAT files support only ASCII character data. If you have non-ASCII character data, writing a Level 4 MAT file is not officially supported. In the event that a Level 4 MAT file is created with such character data, it is unlikely that the original representation of the characters will be preserved.

Converting Character Data

Writing character data to MAT-files using Unicode encoding enables you to share data with users that have systems with a different default system character encoding scheme, without character data loss or corruption. Although conversion between Unicode and other encoding forms is often lossless, there are scenarios in which round-trip conversions can result in loss of data. The following guidelines may reduce your chances of data loss or corruption.

In order to prevent loss or corruption of character data, all users sharing the data must have at least one of the following in common:

- They exchange Unicode-based MAT-files, and use a version of MATLAB that supports these files.

- Their computer systems all use the same default character set, and all character data in the MAT-file was written using the `-nunicode` option

As an illustration, if one user on a Japanese language operating system writes ASCII data having more than 7 bits per character to a MAT-file, another user running MATLAB version 6.5 on an English language operating system will be unable to read the data accurately. However, if both had MATLAB version 7, then the information could be shared freely without loss of data or corruption.

Finding Associated Files

A collection of files associated with reading and writing MAT-files is located on your disk. The following table, MAT-Function Subdirectories, lists the path to the required subdirectories for importing and exporting data using MAT-functions.

Table 1-3: MAT-Function Subdirectories

Platform	Contents	Directories
Windows	Include Files	<matlab>\extern\include
	Libraries	<matlab>\bin\win32
	Examples	<matlab>\extern\examples\eng_mat
UNIX	Include Files	<matlab>/extern/include
	Libraries	<matlab>/extern/lib/\$arch
	Examples	<matlab>/extern/examples/eng_mat

Include Files

The `include` directory holds header files containing function declarations with prototypes for the routines that you can access in the API Library. These files are the same for both Windows and UNIX. Included in the subdirectory are:

- `matrix.h`, the header file that defines MATLAB array access and creation methods
- `mat.h`, the header file that defines MAT-file access and creation methods

Libraries

The subdirectory that contains shared (dynamically linkable) libraries for linking your programs is platform dependent.

Shared Libraries on Windows. The `bin` subdirectory contains the shared libraries for linking your programs:

- The `libmat.dll` library of MAT-file routines (C and Fortran)
- The `libmx.dll` library of array access and creation routines
- The `libut.dll` library of utility routines

Shared Libraries on UNIX. The `extern/lib/$arch` subdirectory, where `$arch` is your machine's architecture, contains the shared libraries for linking your programs. For example, on `sol2`, the subdirectory is `extern/lib/sol2`:

- The `libmat.so` library of MAT-file routines (C and Fortran)
- The `libmx.so` library of array access and creation routines
- The `libut.so` library of utility routines

Example Files

The `examples/eng_mat` subdirectory contains C and Fortran source code for a number of example files that demonstrate how to use the MAT-file routines. The source code files are the same for both Windows and UNIX.

Table 1-4: C and Fortran Examples

Library	Description
<code>matcreat.c</code>	Example C program that demonstrates how to use the library routines to create a MAT-file that can be loaded into MATLAB
<code>matdgns.c</code>	Example C program that demonstrates how to use the library routines to read and diagnose a MAT-file

Table 1-4: C and Fortran Examples (Continued)

Library	Description
matdemo1.f	Example Fortran program that demonstrates how to call the MATLAB MAT-file functions from a Fortran program
matdemo2.f	Example Fortran program that demonstrates how to use the library routines to read in the MAT-file created by matdemo1.f and describe its contents

For additional information about the MATLAB API files and directories, see “Additional Information” on page 3-38.

Examples of MAT-Files

This section includes C and Fortran examples of writing, reading, and diagnosing MAT-files. The examples cover the following topics:

- “Creating a MAT-File in C”
- “Reading a MAT-File in C” on page 1-17
- “Creating a MAT-File in Fortran” on page 1-21
- “Reading a MAT-File in Fortran” on page 1-26

Creating a MAT-File in C

This sample program illustrates how to use the library routines to create a MAT-file that can be loaded into MATLAB. The program also demonstrates how to check the return values of MAT-function calls for read or write failures.

```
/*
 * MAT-file creation program
 *
 * See the MATLAB API Guide for compiling information.
 *
 * Calling syntax:
 *
 *   matcreat
 *
 * Create a MAT-file which can be loaded into MATLAB.
 *
 * This program demonstrates the use of the following functions:
 *
 *   matClose
 *   matGetVariable
 *   matOpen
 *   matPutVariable
 *   matPutVariableAsGlobal
 *
 * Copyright 1984-2000 The MathWorks, Inc.
 * $Revision: 1.13 $
 */
#include <stdio.h>
#include <string.h> /* For strcmp() */
```

```
#include <stdlib.h> /* For EXIT_FAILURE, EXIT_SUCCESS */
#include "mat.h"

#define BUFSIZE 256

int main() {
    MATFile *pmat;
    mxArray *pa1, *pa2, *pa3;
    double data[9] = { 1.0, 4.0, 7.0, 2.0, 5.0, 8.0, 3.0, 6.0, 9.0 };
    const char *file = "mattest.mat";
    char str[BUFSIZE];
    int status;

    printf("Creating file %s...\n\n", file);
    pmat = matOpen(file, "w");
    if (pmat == NULL) {
        printf("Error creating file %s\n", file);
        printf("Do you have write permission in this directory?\n");
        return(EXIT_FAILURE);
    }

    pa1 = mxCreateDoubleMatrix(3,3,mxREAL);
    if (pa1 == NULL) {
        printf("%s : Out of memory on line %d\n", __FILE__,
            __LINE__);
        printf("Unable to create mxArray.\n");
        return(EXIT_FAILURE);
    }

    pa2 = mxCreateDoubleMatrix(3,3,mxREAL);
    if (pa2 == NULL) {
        printf("%s : Out of memory on line %d\n", __FILE__,
            __LINE__);
        printf("Unable to create mxArray.\n");
        return(EXIT_FAILURE);
    }
    memcpy((void *) (mxGetPr(pa2)), (void *) data, sizeof(data));

    pa3 = mxCreateString("MATLAB: the language of technical
        computing");
}
```

```
if (pa3 == NULL) {
    printf("%s : Out of memory on line %d\n", __FILE__,
        __LINE__);
    printf("Unable to create string mxArray.\n");
    return(EXIT_FAILURE);
}

status = matPutVariable(pmat, "LocalDouble", pa1);
if (status != 0) {
    printf("%s : Error using matPutVariable on line %d\n",
        __FILE__, __LINE__);
    return(EXIT_FAILURE);
}

status = matPutVariableAsGlobal(pmat, "GlobalDouble", pa2);
if (status != 0) {
    printf("Error using matPutVariableAsGlobal\n");
    return(EXIT_FAILURE);
}

status = matPutVariable(pmat, "LocalString", pa3);
if (status != 0) {
    printf("%s : Error using matPutVariable on line %d\n",
        __FILE__, __LINE__);
    return(EXIT_FAILURE);
}

/*
 * Oops! we need to copy data before writing the array. (Well,
 * ok, this was really intentional.) This demonstrates that
 * matPutVariable will overwrite an existing array in a MAT-file.
 */
memcpy((void *) (mxGetPr(pa1)), (void *) data, sizeof(data));
status = matPutVariable(pmat, "LocalDouble", pa1);
if (status != 0) {
    printf("%s : Error using matPutVariable on line %d\n",
        __FILE__, __LINE__);
    return(EXIT_FAILURE);
}
```

```
/* Clean up. */
mxDestroyArray(pa1);
mxDestroyArray(pa2);
mxDestroyArray(pa3);

if (matClose(pmat) != 0) {
    printf("Error closing file %s\n",file);
    return(EXIT_FAILURE);
}

/* Re-open file and verify its contents with matGetVariable. */
pmat = matOpen(file, "r");
if (pmat == NULL) {
    printf("Error reopening file %s\n", file);
    return(EXIT_FAILURE);
}

/* Read in each array we just wrote. */
pa1 = matGetVariable(pmat, "LocalDouble");
if (pa1 == NULL) {
    printf("Error reading existing matrix LocalDouble\n");
    return(EXIT_FAILURE);
}
if (mxGetNumberOfDimensions(pa1) != 2) {
    printf("Error saving matrix: result does not have two
           dimensions\n");
    return(EXIT_FAILURE);
}

pa2 = matGetVariable(pmat, "GlobalDouble");
if (pa2 == NULL) {
    printf("Error reading existing matrix GlobalDouble\n");
    return(EXIT_FAILURE);
}
if (!(mxIsFromGlobalWS(pa2))) {
    printf("Error saving global matrix: result is not global\n");
    return(EXIT_FAILURE);
}

pa3 = matGetVariable(pmat, "LocalString");
```

```
    if (pa3 == NULL) {
        printf("Error reading existing matrix LocalString\n");
        return(EXIT_FAILURE);
    }

    status = mxGetString(pa3, str, sizeof(str));
    if(status != 0) {
        printf("Not enough space. String is truncated.");
        return(EXIT_FAILURE);
    }
    if (strcmp(str, "MATLAB: the language of technical
        computing")) {
        printf("Error saving string: result has incorrect
            contents\n");
        return(EXIT_FAILURE);
    }

    /* Clean up before exit. */
    mxDestroyArray(pa1);
    mxDestroyArray(pa2);
    mxDestroyArray(pa3);

    if (matClose(pmat) != 0) {
        printf("Error closing file %s\n",file);
        return(EXIT_FAILURE);
    }
    printf("Done\n");
    return(EXIT_SUCCESS);
}
```

To produce an executable version of this example program, compile the file and link it with the appropriate library. Details on how to compile and link MAT-file programs on the various platforms are discussed in the section, “Compiling and Linking MAT-File Programs” on page 1-30.

Once you have compiled and linked your MAT-file program, you can run the stand-alone application you have just produced. This program creates a MAT-file, `mattest.mat`, that can be loaded into MATLAB. To run the application, depending on your platform, either double-click on its icon or enter `matcreat` at the system prompt.

```
matcreat
Creating file mattest.mat...
```

To verify that the MAT-file has been created, at the MATLAB prompt enter

```
whos -file mattest.mat
  Name              Size           Bytes  Class

  GlobalDouble      3x3             72    double array (global)
  LocalDouble       3x3             72    double array
  LocalString       1x43            86    char array
```

```
Grand total is 61 elements using 230 bytes
```

Reading a MAT-File in C

This sample program illustrates how to use the library routines to read and diagnose a MAT-file.

```
/*
 * MAT-file diagnose program
 *
 * Calling syntax:
 *
 *   matdgn <matfile.mat>
 *
 * It diagnoses the MAT-file named <matfile.mat>.
 *
 * This program demonstrates the use of the following functions:
 *
 *   matClose
 *   matGetDir
 *   matGetNextVariable
 *   matGetNextVariableInfo
 *   matOpen
 *
 * Copyright (c) 1984-2000 The MathWorks, Inc.
 * $Revision: 1.8 $
 */
```

```
#include <stdio.h>
#include <stdlib.h>
#include "mat.h"

int diagnose(const char *file) {
    MATFile *pmat;
    char **dir;
    const char *name;
    int ndir;
    int i;
    mxArray *pa;

    printf("Reading file %s...\n\n", file);

    /* Open file to get directory. */
    pmat = matOpen(file, "r");
    if (pmat == NULL) {
        printf("Error opening file %s\n", file);
        return(1);
    }

    /* Get directory of MAT-file. */
    dir = matGetDir(pmat, &ndir);
    if (dir == NULL) {
        printf("Error reading directory of file %s\n", file);
        return(1);
    } else {
        printf("Directory of %s:\n", file);
        for (i=0; i < ndir; i++)
            printf("%s\n", dir[i]);
    }
    mxFree(dir);

    /* In order to use matGetNextXXX correctly, reopen file to
       read in headers. */
    if (matClose(pmat) != 0) {
        printf("Error closing file %s\n",file);
        return(1);
    }
    pmat = matOpen(file, "r");
}
```

```
if (pmat == NULL) {
    printf("Error reopening file %s\n", file);
    return(1);
}

/* Get headers of all variables. */
printf("\nExamining the header for each variable:\n");
for (i=0; i < ndir; i++) {
    pa = matGetNextVariableInfo(pmat, &name);
    if (pa == NULL) {
        printf("Error reading in file %s\n", file);
        return(1);
    }
    /* Diagnose header pa. */
    printf("According to its header, array %s has %d dimensions\n",
           name, mxGetNumberOfDimensions(pa));
    if (mxIsFromGlobalWS(pa))
        printf(" and was a global variable when saved\n");
    else
        printf(" and was a local variable when saved\n");
    mxDestroyArray(pa);
}

/* Reopen file to read in actual arrays. */
if (matClose(pmat) != 0) {
    printf("Error closing file %s\n",file);
    return(1);
}
pmat = matOpen(file, "r");
if (pmat == NULL) {
    printf("Error reopening file %s\n", file);
    return(1);
}

/* Read in each array. */
printf("\nReading in the actual array contents:\n");
for (i=0; i<ndir; i++) {
    pa = matGetNextVariable(pmat, &name);
    if (pa == NULL) {
        printf("Error reading in file %s\n", file);
    }
}
```

```
        return(1);
    }
    /*
     * Diagnose array pa
     */
    printf("According to its contents, array %s has %d
           dimensions\n", name, mxGetNumberOfDimensions(pa));
    if (mxIsFromGlobalWS(pa))
        printf(" and was a global variable when saved\n");
    else
        printf(" and was a local variable when saved\n");
    mxDestroyArray(pa);
}

if (matClose(pmat) != 0) {
    printf("Error closing file %s\n",file);
    return(1);
}
printf("Done\n");
return(0);
}

int main(int argc, char **argv)
{
    int result;

    if (argc > 1)
        result = diagnose(argv[1]);
    else{
        result = 0;
        printf("Usage: matdgn <matfile>");
        printf(" where <matfile> is the name of the MAT-file");
        printf(" to be diagnosed\n");
    }
    return (result==0) ? EXIT_SUCCESS : EXIT_FAILURE;
}
```

After compiling and linking this program, you can view its results.

```
matdgns mattest.mat
Reading file mattest.mat...
```

```
Directory of mattest.mat:
GlobalDouble
LocalString
LocalDouble
```

```
Examining the header for each variable:
According to its header, array GlobalDouble has 2 dimensions
    and was a global variable when saved
According to its header, array LocalString has 2 dimensions
    and was a local variable when saved
According to its header, array LocalDouble has 2 dimensions
    and was a local variable when saved
```

```
Reading in the actual array contents:
According to its contents, array GlobalDouble has 2 dimensions
    and was a global variable when saved
According to its contents, array LocalString has 2 dimensions
    and was a local variable when saved
According to its contents, array LocalDouble has 2 dimensions
    and was a local variable when saved
Done
```

Creating a MAT-File in Fortran

This example creates a MAT-file, matdemo.mat.

```
C    matdemo1.f
C    This is a simple program that illustrates how to call the
C    MATLAB MAT-file functions from a Fortran program.  This
C    demonstration focuses on writing MAT-files.
C
C    matdemo1 - Create a new MAT-file from scratch.
C
C    Copyright (c) 1984-2000 The MathWorks, Inc.
C    $Revision: 1.9 $
```

```
program matdemo1

integer matOpen, matClose
integer matGetVariable, matPutVariable
integer matPutVariableAsGlobal, matDeleteVariable
integer mxCreateDoubleMatrix, mxCreateString
integer mxIsFromGlobalWS, mxGetPr

integer mp, pa1, pa2, pa3, pa0, status
double precision dat(9)
data dat / 1.0, 2.0, 3.0, 4.0, 5.0, 6.0, 7.0, 8.0, 9.0 /
```

```
C   Open MAT-file for writing.
write(6,*) 'Creating MAT-file matdemo.mat ...'
mp = matOpen('matdemo.mat', 'w')
if (mp .eq. 0) then
    write(6,*) 'Can''t open ''matdemo.mat'' for writing.'
    write(6,*) '(Do you have write permission in this
                directory?)'
    stop
end if

C   Create variables.
pa0 = mxCreateDoubleMatrix(3,3,0)
call mxCopyReal8ToPtr(dat, mxGetPr(pa0), 9)

pa1 = mxCreateDoubleMatrix(3,3,0)

pa2 = mxCreateString('MATLAB: The language of computing')

pa3 = mxCreateString('MATLAB: The language of computing')

status = matPutVariableAsGlobal(mp, 'NumericGlobal', pa0)
if (status .ne. 0) then
    write(6,*) 'matPutVariableAsGlobal ''Numeric Global''
                failed'
    stop
end if
status = matPutVariable(mp, 'Numeric', pa1)
```

```

if (status .ne. 0) then
    write(6,*) 'matPutVariable 'Numeric'' failed'
    stop
end if
status = matPutVariable(mp, 'String', pa2)
if (status .ne. 0) then
    write(6,*) 'matPutVariable 'String'' failed'
    stop
end if
status = matPutVariable(mp, 'String2', pa3)
if (status .ne. 0) then
    write(6,*) 'matPutVariable 'String2'' failed'
    stop
end if

```

C Whoops! Forgot to copy the data into the first matrix --
C it is now blank. Well, ok, this was deliberate. This
C demonstrates that matPutVariable will overwrite existing
C matrices.

```

call mxCopyReal8ToPtr(dat, mxGetPr(pa1), 9)
status = matPutVariable(mp, 'Numeric', pa1)
if (status .ne. 0) then
    write(6,*) 'matPutVariable 'Numeric'' failed 2nd time'
    stop
end if

```

C We will delete String2 from the MAT-file.

```

status = matDeleteVariable(mp, 'String2')
if (status .ne. 0) then
    write(6,*) 'matDeleteVariable 'String2'' failed'
    stop
end if

```

C Finally, read back in MAT-file to make sure we know what
C we put in it.

```

status = matClose(mp)

```

```
if (status .ne. 0) then
    write(6,*) 'Error closing MAT-file'
    stop
end if

mp = matOpen('matdemo.mat', 'r')
if (mp .eq. 0) then
    write(6,*) 'Can''t open ''matdemo.mat'' for reading.'
    stop
end if

pa0 = matGetVariable(mp, 'NumericGlobal')
if (mxIsFromGlobalWS(pa0) .eq. 0) then
    write(6,*) 'Invalid non-global matrix written to MAT-file'
    stop
end if

pa1 = matGetVariable(mp, 'Numeric')
if (mxIsNumeric(pa1) .eq. 0) then
    write(6,*) 'Invalid non-numeric matrix written to
                MAT-file'

    stop
end if

pa2 = matGetVariable(mp, 'String')
if (mxIsString(pa2) .eq. 0) then
    write(6,*) 'Invalid non-string matrix written to MAT-file'
    stop
end if

pa3 = matGetVariable(mp, 'String2')
if (pa3 .ne. 0) then
    write(6,*) 'String2 not deleted from MAT-file'
    stop
end if

C    Clean up memory.
    call mxDestroyArray(pa0)
    call mxDestroyArray(pa1)
```



```
call mxDestroyArray(pa2)
call mxDestroyArray(pa3)

status = matClose(mp)
if (status .ne. 0) then
    write(6,*) 'Error closing MAT-file'
    stop
end if

write(6,*) 'Done creating MAT-file'
stop
end
```

Once you have compiled and linked your MAT-file program, you can run the stand-alone application you have just produced. This program creates a MAT-file, `matdemo.mat`, that can be loaded into MATLAB. To run the application, depending on your platform, either double-click on its icon or enter `matdemo1` at the system prompt.

```
matdemo1
Creating MAT-file matdemo.mat ...
Done creating MAT-file
```

To verify that the MAT-file has been created, at the MATLAB prompt enter

```
whos -file matdemo.mat
Name           Size           Bytes  Class

Numeric        3x3             72    double array
String          1x33            66    char array
```

```
Grand total is 42 elements using 138 bytes
```

Note For an example of a Windows stand-alone program (not MAT-file specific), see `engwindemo.c` in the `<matlab>\extern\examples\eng_mat` directory.

Reading a MAT-File in Fortran

This sample program illustrates how to use the library routines to read in the MAT-file created by `matdemo1.f` and describe its contents.

```
C      matdemo2.f
C
C      This is a simple program that illustrates how to call the
C      MATLAB MAT-file functions from a Fortran program. This
C      demonstration focuses on reading MAT-files. It reads in
C      the MAT-file created by matdemo1.f and describes its
C      contents.
C
C      Copyright (c) 1984-2000 The MathWorks, Inc.
C      $Revision: 1.11 $

      program matdemo2

      integer matOpen, matClose, matGetDir
      integer matGetNextVariable, matGetNextVariableInfo
      integer mxGetM, mxGetN

      integer mp, dir, adir(100), pa
      integer ndir, i, stat
      character*32 names(100), name

C      Open file and read directory.
      mp = matOpen('matdemo.mat', 'r')
      if (mp .eq. 0) then
          write(6,*) 'Can''t open ''matdemo.mat''.'
          stop
      end if

      dir = matgetdir(mp, ndir)
      if (dir .eq. 0) then
          write(6,*) 'Can''t read directory.'
          stop
      endif

C      Copy pointer into an array of pointers.
      call mxCopyPtrToPtrArray(dir, adir, ndir)
```

```

C      Copy pointer to character string.
      do 20 i=1,ndir
          call mxCopyPtrToCharacter(adir(i), names(i), 32)
20 continue

      write(6,*) 'Directory of Mat-file:'
      do 30 i=1,ndir
          write(6,*) names(i)
30 continue

      stat = matClose(mp)
      if (stat .ne. 0) then
          write(6,*) 'Error closing ''matdemo.mat''.'
          stop
      end if

C      Reopen file and read full arrays.
      mp = matOpen('matdemo.mat', 'r')
      if (mp .eq. 0) then
          write(6,*) 'Can''t open ''matdemo.mat''.'
          stop
      end if

C      Get Information on first array in mat file.
      write(6,*) 'Getting Header info from first array.'
      pa = matGetVariableInfo(mp, names(1))
      write(6,*) 'Retrieved ', names(1)
      write(6,*) ' With size ', mxGetM(pa), '-by-', mxGetN(pa)
      call mxDestroyArray(pa)

      write(6,*) 'Getting Header info from next array.'
      pa = matGetNextVariableInfo(mp, name)
      write(6,*) 'Retrieved ', name
      write(6,*) ' With size ', mxGetM(pa), '-by-', mxGetN(pa)
      call mxDestroyArray(pa)

C      Read directory.
      write(6,*) 'Getting rest of array contents:'
      pa = matGetNextVariable(mp, name)

```

```
C      Copy name to character string.
      do while (pa .ne. 0)
         i=mxGetM(pa)
         write(*, *) i
         write(6,*) 'Retrieved ', name
         write(6,*) ' With size ', mxGetM(pa), '-by-', mxGetN(pa)
         call mxDestroyArray(pa)
         pa = matGetNextVariable(mp, name)
      end do

      stat = matClose(mp)
      if (stat .ne. 0) then
         write(6,*) 'Error closing ''matdemo.mat''.'
         stop
      end if
      stop
      end
```

After compiling and linking this program, you can view its results.

```
matdemo2
Directory of Mat-file:
String
Numeric
Getting full array contents:
  1
Retrieved String
  With size  1-by- 33
  3
Retrieved Numeric
  With size  3-by-  3
```

Compiling and Linking MAT-File Programs

This section describes the steps required to compile and link MAT-file programs on UNIX and Windows systems. It begins by looking at a special consideration for compilers that do not mask floating-point exceptions. Topics covered are:

- “Masking Floating Point Exceptions”
- “Compiling and Linking on UNIX” on page 1-31
- “Compiling and Linking on Windows” on page 1-33
- “Required Files from Third-Party Sources” on page 1-33
- “Working Directly with Unicode” on page 1-35

Masking Floating Point Exceptions

Certain mathematical operations can result in nonfinite values. For example, division by zero results in the nonfinite IEEE value, `inf`. A floating-point exception occurs when such an operation is performed. Because MATLAB uses an IEEE model that supports nonfinite values such as `inf` and `NaN`, MATLAB disables, or *masks*, floating-point exceptions.

Some compilers do not mask floating-point exceptions by default. This causes MAT-file applications built with such compilers to terminate when a floating-point exception occurs. Consequently, you need to take special precautions when using these compilers to mask floating-point exceptions so that your MAT-file application will perform properly.

Note MATLAB-based applications should never get floating-point exceptions. If you do get a floating-point exception, verify that any third party libraries that you link against do not enable floating-point exception handling.

The only compiler and platform on which you need to mask floating-point exceptions is the Borland C++ compiler on Windows.

Borland C++ Compiler on Windows

To mask floating-point exceptions when using the Borland C++ compiler on the Windows platform, you must add some code to your program. Include the following at the beginning of your `main()` or `WinMain()` function, before any calls to MATLAB API functions.

```
#include <float.h>
.
.
.
_control187(MCW_EM,MCW_EM);
.
.
.
```

Compiling and Linking on UNIX

Under UNIX at runtime, you must tell the system where the API shared libraries reside. These sections provide the necessary UNIX commands depending on your shell and system architecture.

Setting Runtime Library Path

In C shell, the command to set the library path is

```
setenv LD_LIBRARY_PATH $MATLAB/bin/$ARCH
```

where `$MATLAB` is the MATLAB root directory and `$ARCH` is your system architecture on which MATLAB is supported.

In Bourne shell, the commands to set the library path are

```
LD_LIBRARY_PATH=$MATLAB/bin/$ARCH:$LD_LIBRARY_PATH
export LD_LIBRARY_PATH
```

Setting Runtime Library Path on Macintosh

On the Macintosh platform, the library path variable is called `DYLD_LIBRARY_PATH`. Use the following commands to set the library path:

In C shell, the command to set the library path is

```
setenv DYLD_LIBRARY_PATH
$MATLAB/bin/mac:$MATLAB/sys/os/mac:$DYLD_LIBRARY_PATH
```

In Bourne shell, the commands to set the library path are

```
DYLD_LIBRARY_PATH=  
$MATLAB/bin/mac:$MATLAB/sys/os/mac:$DYLD_LIBRARY_PATH  
export DYLD_LIBRARY_PATH
```

Platform-Specific Environment Variables

Note that the environment variable (LD_LIBRARY_PATH in this example) varies on several platforms. The following table lists the different environment variable names you should use on these systems.

Table 1-5: Environment Variable Names

Architecture	Environment Variable
HP-UX	SHLIB_PATH
Mac OS X	DYLD_LIBRARY_PATH

It is convenient to place these commands in a startup script such as `~/ .cshrc` for C shell or `~/ .profile` for Bourne shell.

Using the Options File

MATLAB provides an options file, `matopts.sh`, that lets you use the `mex` script to easily compile and link MAT-file applications. For example, to compile and link the `matcreat.c` example, first copy the file

```
$MATLAB/extern/examples/eng_mat/matcreat.c
```

(where `$MATLAB` is the MATLAB root directory) to a directory that is writable, and then use the following command to build it:

```
mex -f $MATLAB/bin/matopts.sh matcreat.c
```

If you need to modify the options file for your particular compiler or platform, use the `-v` switch to view the current compiler and linker settings and then make the appropriate changes in a local copy of the `matopts.sh` file.

Compiling and Linking on Windows

To compile and link Fortran or C MAT-file programs, use the `mex` script with a MAT options file. The MAT options files reside in `$MATLAB\bin\win32\mexopts` and are named `*engmatopts.bat`, where `*` represents the compiler type (e.g., `bcc` for Borland, `wat` for Watcom, etc.).

For example, to compile and link the stand-alone MAT application `matcreat.c` using MSVC Version 7.1 on Windows, first copy the file

```
$MATLAB\extern\examples\eng_mat\matcreat.c
```

(where `$MATLAB` is the MATLAB root directory) to a directory that is writable, and then use the following command to build it:

```
mex -f $MATLAB\bin\win32\mexopts\msvc71engmatopts.bat matcreat.c
```

If you need to modify the options file for your particular compiler, use the `-v` switch to view the current compiler and linker settings and then make the appropriate changes in a local copy of the options file.

Required Files from Third-Party Sources

MATLAB requires the following data and library files for building any MAT-file application. You must also distribute these files along with any MAT-file application that you deploy to another system:

Third-Party Data Files

When building a MAT-file application on your system or deploying a MAT-file application to some other system, make sure that the appropriate Unicode data file is installed in the `$MATLAB/bin/$ARCH` directory. MATLAB uses this file to support Unicode.

For systems that order bytes in a big-endian manner, use

```
icudt24b.dat.
```

For systems that order bytes in a little-endian manner, use

```
icudt24l.dat.
```

Third-Party Libraries

When building a MAT-file application on your system or deploying a MAT-file application to some other system, make sure that the appropriate libraries are installed in the `$MATLAB/bin/$ARCH` directory (where `$MATLAB` is the MATLAB root directory and `$ARCH` is your system architecture).

On UNIX	On Windows
-----	-----
<code>libmat.{so dylib sl}</code>	<code>libmat.dll</code>
<code>libmx.{so dylib sl}</code>	<code>libmx.dll</code>
<code>libut.{so dylib sl}</code>	<code>libut.dll</code>

In addition to these libraries, you must also have all third-party library files that `libmat` depends on. MATLAB uses these additional libraries to support Unicode character encoding and data compression in MAT-files. These library files must reside in the same directory as `libmx` and `libut`.

You can determine what most of these libraries are using the platform-specific methods described below.

On Linux, Solaris, or HP-UX Systems

Type the following command:

```
ldd -d libmat.{so|sl}
```

On Macintosh Systems

Type the following command:

```
otool -L libmat.dylib
```

On Windows Systems

Download the Dependency Walker utility from the following Web site

```
http://www.dependencywalker.com/
```

and then drag-and-drop the file `$MATLAB/bin/win32/libmat.dll` into Depends window. (`$MATLAB` represents the MATLAB root directory).

Working Directly with Unicode

If you need to manipulate Unicode text directly in your application, version 2.4 of International Components for Unicode (ICU) is freely available online from the IBM Corporation Web site at:

`http://oss.software.ibm.com/icu/download/2.4/index.html`

MATLAB Interface to Generic DLLs

A shared library is a collection of functions that are available for use by one or more applications running on a system. On Windows systems, the library is precompiled into a dynamic link library (.dll) file. At run-time, the library is loaded into memory and made accessible to all applications. The MATLAB Interface to Generic DLLs enables you to interact with functions in dynamic link libraries directly from MATLAB.

This chapter covers the following topics.

Overview (p. 2-2)

Provides a brief introduction to the interface.

Loading and Unloading the Library
(p. 2-3)

Describes functions to use in loading the library into MATLAB memory and later releasing that memory.

Getting Information About the Library
(p. 2-4)

Shows several ways of obtaining information about the functions contained in a library.

Invoking Library Functions (p. 2-7)

Tells you how to make a call to any function in the library.

Passing Arguments (p. 2-8)

Explains how to construct MATLAB arguments that are compatible with the argument types found in the library functions.

Data Conversion (p. 2-11)

Describes how to convert MATLAB data to C data types when you need to do the conversion manually.

Overview

C programs built into external, shared libraries are easily accessed by MATLAB through a command line interface. This interface gives you the ability to load an external library into MATLAB memory space and then access any of the functions defined therein. Although data types differ between the two language environments, in most cases you can pass MATLAB types to the C functions without having to do the work of conversion. MATLAB does this for you.

This interface also supports libraries containing functions programmed in languages other than C, provided that the functions have a C interface.

Loading and Unloading the Library

To give MATLAB access to external functions in a shared library, you must first load the library into memory. Once loaded, you can request information about any of the functions in the library and call them directly from MATLAB. When the library is no longer needed, you will need to unload it from memory to conserve memory usage.

Loading the Library

To load a shared library into MATLAB, use the `loadlibrary` function. The syntax for `loadlibrary` is

```
loadlibrary('shrlib', 'hfile')
```

where `shrlib` is the filename for the `.dll` shared library file, and `hfile` is the filename for the header file that contains the function prototypes. See the reference page for `loadlibrary` for variations in the syntax that you can use.

Note The header file provides signatures for the functions in the library and is a required argument for `loadlibrary`.

As an example, you can use `loadlibrary` to load the `libmx` library that defines the MATLAB `mx` routines. The first statement below forms the directory specification for the `matrix.h` header file for the `mx` routines. The second loads the library from `libmx.dll`, also specifying the header file:

```
hfile = [matlabroot '\extern\include\matrix.h'];  
loadlibrary('libmx', hfile)
```

There are also several optional arguments that you can use with `loadlibrary`. See the `loadlibrary` reference page for more information.

Unloading the Library

To unload the library and free up the memory that it occupied, use the `unloadlibrary` function. For example,

```
unloadlibrary libmx
```

Getting Information About the Library

You can use either of two functions to get information on the functions available in a library that you have loaded:

```
libfunctions('libname')
```

```
libfunctionsview('libname')
```

The main difference is that `libfunctions` displays the information in the MATLAB Command Window (and you can assign its output to a variable), and `libfunctionsview` displays the information as a graphical display in a new window.

To see what functions are available in the `libmx` library, use `libfunctions`, specifying the library filename as the only argument. Note that you can use the MATLAB command syntax (with no parentheses or quotes required) when specifying no output variables:

```
libfunctions libmx
```

```
Methods for class lib.libmx:
```

<code>mxAddField</code>	<code>mxGetFieldNumber</code>	<code>mxIsLogicalScalarTrue</code>
<code>mxArrayToString</code>	<code>mxGetImagData</code>	<code>mxIsNaN</code>
<code>mxCalcSingleSubscript</code>	<code>mxGetInf</code>	<code>mxIsNumeric</code>
<code>mxCalloc</code>	<code>mxGetIr</code>	<code>mxIsObject</code>
<code>mxClearScalarDoubleFlag</code>	<code>mxGetJc</code>	<code>mxIsOpaque</code>
<code>mxCreateCellArray</code>	<code>mxGetLogicals</code>	<code>mxIsScalarDoubleFlagSet</code>
<code>.</code>	<code>.</code>	<code>.</code>
<code>.</code>	<code>.</code>	<code>.</code>

To list the functions along with their signatures, use the `-full` switch with `libfunctions`. This shows the MATLAB syntax for calling functions written in C. The data types used in the argument lists and return values match MATLAB types, not C types. See the section “Data Conversion” on page 2-11 for more information on these data types.

```
libfunctions libmx -full
```

```
Methods for class lib.libmx:
```

```
[mxClassID, MATLAB array] mxGetClassID(MATLAB array)
[lib.pointer, MATLAB array] mxGetData(MATLAB array)
[MATLAB array, voidPtr] mxSetData(MATLAB array, voidPtr)
[lib.pointer, MATLAB array] mxGetPr(MATLAB array)
[MATLAB array, doublePtr] mxSetPr(MATLAB array, doublePtr)
uint8 mxIsFinite(double)
uint8 mxIsInf(double)
:
:
```

Viewing Functions in a GUI Interface

The `libfunctionsview` function creates a new window that displays all of the functions defined in a specific library. For each method, the following information is shown.

Heading	Description
Return Type	Data types that the method returns
Name	Function name
Arguments	Valid data types for input arguments
Inherited From	Not relevant for shared library functions

The following command opens the window shown below for the `libmx` library:

```
libfunctionsview libmx
```

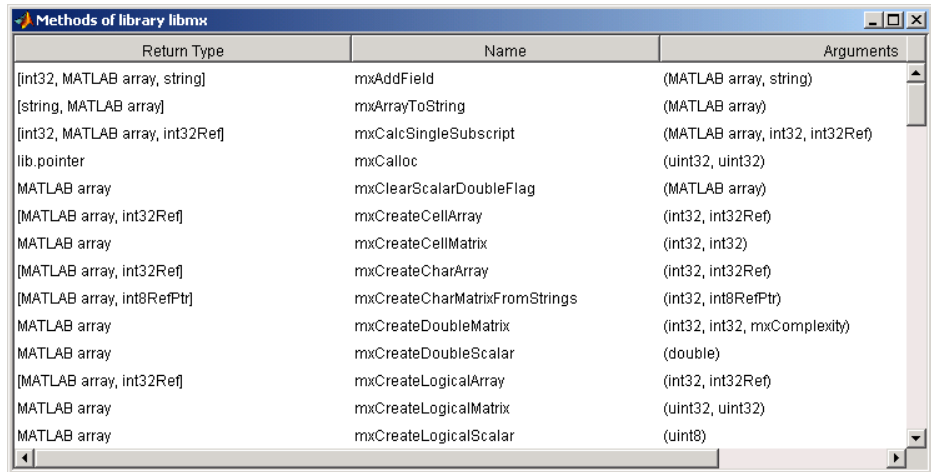

Return Type	Name	Arguments
[int32, MATLAB array, string]	<code>mxAddField</code>	(MATLAB array, string)
[string, MATLAB array]	<code>mxArrayToString</code>	(MATLAB array)
[int32, MATLAB array, int32Ref]	<code>mxCalcSingleSubscript</code>	(MATLAB array, int32, int32Ref)
<code>lib.pointer</code>	<code>mxCalloc</code>	(uint32, uint32)
MATLAB array	<code>mxClearScalarDoubleFlag</code>	(MATLAB array)
[MATLAB array, int32Ref]	<code>mxCreateCellArray</code>	(int32, int32Ref)
MATLAB array	<code>mxCreateCellMatrix</code>	(int32, int32)
[MATLAB array, int32Ref]	<code>mxCreateCharArray</code>	(int32, int32Ref)
[MATLAB array, int8RefPtr]	<code>mxCreateCharMatrixFromStrings</code>	(int32, int8RefPtr)
MATLAB array	<code>mxCreateDoubleMatrix</code>	(int32, int32, mxComplexity)
MATLAB array	<code>mxCreateDoubleScalar</code>	(double)
[MATLAB array, int32Ref]	<code>mxCreateLogicalArray</code>	(int32, int32Ref)
MATLAB array	<code>mxCreateLogicalMatrix</code>	(uint32, uint32)
MATLAB array	<code>mxCreateLogicalScalar</code>	(uint8)

As was true for the `libfunctions` function, the data types displayed here are MATLAB types. See the section “Data Conversion” on page 2-11 for more information on these data types.

Invoking Library Functions

Once a shared library has been loaded into MATLAB, use the `calllib` function to call any of the functions from that library. Specify the library name, function name, and any arguments that get passed to the function:

```
calllib('libname', 'funcname', arg1, ..., argN)
```

This example calls functions from the `libmx` library to test the value stored in `y`.

```
hfile = [matlabroot '\extern\include\matrix.h'];  
loadlibrary('libmx', hfile)
```

```
y = rand(4, 7, 2);
```

```
calllib('libmx', 'mxGetNumberOfElements', y)  
ans =  
    56
```

```
calllib('libmx', 'mxGetClassID', y)  
ans =  
    mxDOUBLE_CLASS
```

Passing Arguments

To determine which MATLAB data types to use when passing arguments to library functions, see the output of `libfunctionsview` or `libfunctions -full`. These functions list all of the functions found in a particular library along with a specification of the data types required for each argument.

A sample external library called `shrlibsample` is supplied with MATLAB. The `.dll` file for the `shrlibsample` library resides in the directory, `extern\examples\shrlib`. To use the `shrlibsample` library, you first need to either add this directory to your MATLAB path with the command,

```
addpath([matlabroot '\extern\examples\shrlib'])
```

or make this your current working directory with the command,

```
cd([matlabroot '\extern\examples\shrlib'])
```

The following example loads the `shrlibsample` library and displays some of the functions that come with the library:

```
loadlibrary shrlibsample shrlibsample.h
libfunctions shrlibsample -full

doublePtr multDoubleArray(doublePtr, int32)
double addMixedTypes(int16, int32, double)
[double, doublePtr] addDoubleRef(double, doublePtr, double)
[string, string] stringToUpper(string)
string readEnum(Enum1)
double addStructFields(c_struct)
[lib.pointer, doublePtr] multDoubleRef(doublePtr)
[double, c_structPtr] addStructByRef(c_structPtr)
c_structPtrPtr allocateStruct(c_structPtrPtr)
voidPtr deallocateStruct(voidPtr)
int16Ptr multiplyShort(int16Ptr, int32)
```

These functions are all written in C. What you see here is the MATLAB syntax for calling the C functions.

Some General Rules

There are a few interesting things to note about the input and output arguments shown in the function listing above:

- Many of the arguments (like `int32`, `double`) are very similar to their C counterparts. In these cases, you only need to pass in the MATLAB data types shown for these arguments.
- Some arguments in C (like `**double`, or predefined structures), are quite different from standard MATLAB data types. In these cases, you usually have the option of either passing a standard MATLAB type and letting MATLAB convert it for you, or converting the data yourself using MATLAB functions like `libstruct` and `libpointer`. See the next section on “Data Conversion” on page 2-11.
- C input arguments are often passed by reference. Although MATLAB does not support passing by reference, you can create MATLAB arguments that are compatible with C references. In the listing shown above, these are the arguments with names ending in `Ptr` and `PtrPtr`. See “Creating References” on page 2-21.
- C functions often return data in input arguments passed by reference. MATLAB creates additional output arguments to return these values. Note in the listing shown above that all input arguments ending in `Ptr` or `PtrPtr` are also listed as outputs.

A few general guidelines on passing arguments:

- Nonscalar arguments must be declared as passed by reference in the library functions.
- If the library function uses single subscript indexing to reference a two-dimensional matrix, keep in mind that C programs process matrices row by row while MATLAB processes matrices by column. To get C behavior from the function, transpose the input matrix before calling the function, and then transpose the function output.

- When passing an array having more than two dimensions, the shape of the array may be altered by MATLAB. To ensure that the array retains its shape, store the size of the array before making the call, and then use this same size to reshape the output array to the correct dimensions:

```
vs = size(vin)           % Store the original dimensions
vs =
     2     5     2

vout = calllib('shrllibsample','multDoubleArray', vin, 20);

size(vout)              % Dimensions have been altered
ans =
     2    10

vout = reshape(vout, vs); % Restore the array to 2-by-5-by-2

size(vout)
ans =
     2     5     2
```

- Use an empty array, [], to pass a NULL parameter to a library function that supports optional input arguments. This is valid only when the argument is declared as a Ptr or PtrPtr as shown by libfunctions or libfunctionsview.

Passing References

Many functions in external libraries use arguments that are passed by reference. To enable you to interact with these functions, MATLAB passes what is called a *pointer object* to these arguments. This should not be confused with “passing by reference” in the typical sense of the term. See “Creating References” on page 2-21 for more information.

Data Conversion

This section contains information on how MATLAB handles conversion of argument data and how to convert data yourself when you decide that would be more efficient.

Under most conditions, data passed to and from external library functions is automatically converted by MATLAB to the data type expected by the external function. However, you may choose, at times, to convert some of your argument data manually. Circumstances under which you might find this advantageous are

- When you pass the same piece of data to a series of library functions, it probably makes more sense to convert it once manually at the start rather than having MATLAB convert it automatically on every call. This saves time on unnecessary copy and conversion operations.
- When you pass large structures, you can save memory by creating MATLAB structures that match the shape of the C structures used in the external function instead of using generic MATLAB structures. The `libstruct` function creates a MATLAB structure modeled from a C structure taken from the library.
- When an argument to an external function uses more than one level of referencing (e.g., `double **`), you will need to pass a reference (constructed by the `libpointer` function) rather than have MATLAB convert the data type automatically.

Primitive Types

All standard scalar C data types are supported by the shared library interface. These are shown in the two tables below along with their equivalent MATLAB types. MATLAB uses the type from the right column for arguments having the C type shown in the left column.

(The second table shows *extended* MATLAB types in the right column. These are instances of the MATLAB `lib.pointer` class rather than standard

MATLAB data types. See “Creating References” on page 2-21 for information on the `lib.pointer` class.)

C Type (on a 32-bit computer)	Equivalent MATLAB Type
<code>char, byte</code>	<code>int8</code>
<code>unsigned char, byte</code>	<code>uint8</code>
<code>short</code>	<code>int16</code>
<code>unsigned short</code>	<code>uint16</code>
<code>int, long</code>	<code>int32</code>
<code>unsigned int, unsigned long</code>	<code>uint32</code>
<code>float</code>	<code>single</code>
<code>double</code>	<code>double</code>
<code>char *</code>	<code>string (1xn char array)</code>

C Type (on a 32-bit computer)	Extended MATLAB Type
<code>integer pointer types (int *)</code>	<code>(u)int(size)Ptr</code>
<code>float *</code>	<code>singlePtr</code>
<code>double *</code>	<code>doublePtr</code>
<code>mxArray *</code>	<code>MATLAB array</code>
<code>void *</code>	<code>voidPtr</code>
<code>type **</code>	Same as <code>typePtr</code> with an added <code>Ptr</code> (e.g., <code>double **</code> is <code>doublePtrPtr</code>)

Converting to Other Primitive Types

For primitive types, MATLAB automatically converts any argument to the data type expected by the external function. This means that you can pass a double to a function that expects to receive a byte (8-bit integer) and MATLAB does the conversion for you.

For example, the C function shown here takes arguments that are of types short, int, and double:

```
double addMixedTypes(short x, int y, double z)
{
    return (x + y + z);
}
```

You can simply pass all of the arguments as type double from MATLAB. MATLAB determines what type of data is expected for each argument and performs the appropriate conversions:

```
calllib('shrlibsample', 'addMixedTypes', 127, 33000, pi)
ans =
    3.3130e+004
```

Converting to a Reference

MATLAB also automatically converts an argument passed by value into an argument passed by reference when the external function prototype defines the argument as a reference. So a MATLAB double argument passed to a function that expects double * is converted to a double reference by MATLAB.

addDoubleRef is a C function that takes an argument of type double *:

```
double addDoubleRef(double x, double *y, double z)
{
    return (x + *y + z);
}
```

Call the function with three arguments of type double, and MATLAB handles the conversion:

```
calllib('shrlibsample', 'addDoubleRef', 1.78, 5.42, 13.3)
ans =
    20.5000
```

Strings

For arguments that require `char *`, you can pass a MATLAB string (i.e., character array).

This C function takes a `char *` input argument:

```
char* stringToUpper(char *input) {
    char *p = input;

    if (p != NULL)
        while (*p!=0)
            *p++ = toupper(*p);
    return input;
}
```

`libfunctions` shows that you can use a MATLAB string for this input.

```
libfunctions shrllibsample -full
    [string, string] stringToUpper(string)
```

Create a MATLAB character array, `str`, and pass it as the input argument:

```
str = 'This was a Mixed Case string';
calllib('shrllibsample', 'stringToUpper', str)
ans =
    THIS WAS A MIXED CASE STRING
```

Note Although the input argument that MATLAB passes to `stringToUpper` resembles a reference to type `char`, it is not a true reference data type. That is, it does not contain the address of the MATLAB character array, `str`. So, when the function executes, it returns the correct result but does not modify the value in `str`. If you now examine `str`, you find that its original value is unchanged:

```
str
str =
    This was a Mixed Case string
```

Enumerated Types

For arguments defined as C enumerated types, you can pass either the enumeration string or its integer equivalent.

The `readEnum` function from the `shrllibsample` library returns the enumeration string that matches the argument passed in. Here is the `Enum1` definition and the `readEnum` function in C:

```
enum Enum1 {en1 = 1, en2, en4 = 4} TEnum1;

char* readEnum(TEnum1 val) {
    switch (val) {
        case 1 :return "You chose en1";
        case 2: return "You chose en2";
        case 4: return "You chose en4";
        default : return "enum not defined";
    }
}
```

In **MATLAB**, you can express an enumerated type as either the enumeration string or its equivalent numeric value. The `TEnum1` definition above declares enumeration `en4` to be equal to 4. Call `readEnum` first with a string:

```
calllib('shrllibsample', 'readEnum', 'en4')
ans =
    You chose en4
```

Now call it with the equivalent numeric argument, 4:

```
calllib('shrllibsample', 'readEnum', 4)
ans =
    You chose en4
```

Structures

For library functions that take structure arguments, you need to pass structures that have field names that are the same as those in the structure definitions in the library. To determine the names and also the data types of structure fields, you can do one of the following:

- Consult the documentation that was provided with the library.
- Look for the structure definition in the header file that you used to load the library into MATLAB.

You can also determine the field names of an externally defined structure from within MATLAB using the following procedure. When you create and initialize the structure, you don't necessarily have to match the data types of numeric fields. MATLAB converts to the correct numeric type for you when you make the call using the `calllib` function. To get the structure field names:

- 1 Use `libfunctionsview` to display the signatures for all functions in the library you are using. `libfunctionsview` shows the names of the structures used by each function. For example, when you type

```
libfunctionsview shrlibsampl
```

MATLAB opens a new window displaying function signatures for the `shrlibsampl` library. The line showing the `addStructFields` function reads:

```
double addStructFields (c_struct)
```

- 2 If the function you are interested in takes a structure argument, get the structure type from the `libfunctionsview` display, and invoke the `libstruct` function on that type. `libstruct` returns an object that is modeled on the structure as defined in the library:

```
s = libstruct('c_struct');
```

- 3 Get the names of the structure fields from the object returned by `libstruct`:

```
get(s)
  p1: 0
  p2: 0
  p3: 0
```

- 4 Initialize the fields to the values you want to pass to the library function and make the call using `calllib`:

```
s.p1 = 476;   s.p2 = -299;   s.p3 = 1000;
calllib('shrlibsampl', 'addStructFields', s)
```

Specifying Structure Field Names

Here are a few general guidelines that apply to structures passed to external library functions:

- These structures may contain fewer fields than defined in the library structure. MATLAB sets any undefined or uninitialized fields to zero.
- Any structure field name that you use must match a field name in the structure definition. Structure names are case sensitive.
- Structures cannot contain additional fields that are not in the library structure definition.

Passing a MATLAB Structure

As with other data types, when an external function takes a structure argument (such as a C structure), you can pass a MATLAB structure to the function in its place. Structure field names must match field names defined in the library, but data types for numeric fields do not have to match. MATLAB converts each numeric field of the MATLAB structure to the correct data type.

Example of Passing a MATLAB Structure. The sample shared library, `shr1libsample`, defines the following C structure and function:

```
struct c_struct {
    double p1;
    short p2;
    long p3;
};

double addStructFields(struct c_struct st)
{
    double t = st.p1 + st.p2 + st.p3;
    return t;
}
```

The following code passes a MATLAB structure, `sm`, with three double fields to `addStructFields`. MATLAB converts the fields to the double, short, and long data types defined in the C structure, `c_struct`.

```
sm.p1 = 476;    sm.p2 = -299;    sm.p3 = 1000;

calllib('shrlibsample', 'addStructFields', sm)
ans =
    1177
```

Passing a libstruct Object

When you pass a structure to an external function, MATLAB makes sure that the structure being passed matches the library's definition for that structure type. It must contain all the necessary fields defined for that type and each field must be of the expected data type. For any fields that are missing in the structure being passed, MATLAB creates an empty field of that name and initializes its value to zero. For any fields that have a data type that doesn't match the structure definition, MATLAB converts the field to the expected type.

When working with small structures, it is efficient enough to have MATLAB do this work for you. You can pass the original MATLAB structure with `calllib` and let MATLAB handle the conversions automatically. However, when working with repeated calls that pass one or more large structures, it may be to your advantage to convert the structure manually before making any calls to external functions. In this way, you save processing time by converting the structure data only once at the start rather than at each function call. You can also save memory if the fields of the converted structure take up less space than the original MATLAB structure.

Using the `libstruct` Function. You can convert a MATLAB structure to a C-like structure derived from a specific type definition in the library in one step. Call the `libstruct` function, passing in the name of the structure type from the library, and the original structure from MATLAB. The syntax for `libstruct` is

```
s = libstruct('structtype', mlstruct)
```

The value `s` returned by this function is called a *libstruct object*. Although it is truly a MATLAB object, it handles much like a MATLAB structure. The fields of this new "structure" are derived from the external structure type specified by `structtype` in the syntax above.

For example, to convert a MATLAB structure, `sm`, to a `libstruct` object, `sc`, that is derived from the `c_struct` structure type, use

```
sm.p1 = 476;    sm.p2 = -299;    sm.p3 = 1000;
sc = libstruct('c_struct', sm);
```

The original structure, `sm`, has fields that are all of type `double`. The object, `sc`, returned from the `libstruct` call has fields that match the `c_struct` structure type. These fields are `double`, `short`, and `long`.

Note You can only use `libstruct` on scalar structures.

Creating an Empty `libstruct` Object. You can also create an empty `libstruct` object by calling `libstruct` with only the `structtype` argument. This constructs an object with all the required fields and with each field initialized to zero.

```
s = libstruct('structtype')
```

`libstruct` Requirements for Structures. when converting a MATLAB structure to a `libstruct` object, the structure to be converted must adhere to the same guidelines that were documented for MATLAB structures passed directly to external functions. See “Specifying Structure Field Names” on page 2-17.

Using the Structure as an Object

The value returned by `libstruct` is not a true MATLAB structure. It is actually an instance of a class called `lib.c_struct`, as seen by examining the output of `whos`:

```
whos sc
  Name      Size      Bytes  Class
  sc        1x1                lib.c_struct
```

```
Grand total is 1 element using 0 bytes
```

The fields of this structure are implemented as properties of the `lib.c_struct` class. You can read and modify any of these fields using the MATLAB object-oriented functions, `set` and `get`:

```
sc = libstruct('c_struct');

set(sc, 'p1', 100, 'p2', 150, 'p3', 200);

get(sc)
    p1: 100
    p2: 150
    p3: 200
```

You can also read and modify the fields by simply treating them like any other MATLAB structure fields:

```
sc.p1 = 23;

sc.p1
ans =
    23
```

Example of Passing a `libstruct` Object

Repeat the `addStructFields` example, this time converting the structure to one of type `c_struct` before calling the function:

```
sm.p1 = 476;  sm.p2 = -299;  sm.p3 = 1000;
sc = libstruct('c_struct', sm);

get(sc)
    p1: 476
    p2: -299
    p3: 1000
```

Now call the function, passing the structure `sc`:

```
calllib('shrlibsample', 'addStructFields', sc)
ans =
    1177
```

Note When passing manually converted structures, the structure passed must be of the same type as that used by the external function. For example, you cannot pass a structure of type records to a function that expects type `c_struct`.

Creating References

You can pass most arguments to an external function by value, even when the prototype for that function declares the argument to be a reference. However, you may find times when it is useful to pass a MATLAB argument that is the equivalent of a C reference.

Using the `libpointer` Function

To construct a reference, use the function `libpointer` with this syntax:

```
p = libpointer('type', 'value')
```

To give an example, create a pointer `pv` to an `int16` value. In the first argument to `libpointer`, enter the type of pointer you are creating. The type name is always the data type (`int16`, in this case) suffixed by the letters `Ptr`:

```
v = int16(485);  
pv = libpointer('int16Ptr', v);
```

The value returned, `pv`, is actually an instance of a MATLAB class called `lib.pointer`. The `lib.pointer` class has the properties `Value` and `DataType`. You can read and modify these properties with the MATLAB `get` and `set` functions:

```
get(pv)  
    Value: 485  
    DataType: 'int16Ptr'
```

The `lib.pointer` class also has two methods, `setdatatype` and `reshape`, that are described in the next section, “Obtaining the Function’s Return Values” on page 2-23:

```
methods(pv)

Methods for class lib.pointer:
    setdatatype  reshape
```

Creating a Reference to a Primitive Type

Here is a simple example that illustrates how to construct and pass a pointer to type `double`, and how to interpret the output data. The function `multDoubleRef` takes one input that is a reference to a `double` and returns the same.

Here is the C function:

```
double *multDoubleRef(double *x)
{
    *x *= 5;
    return x;
}
```

Construct a reference, `xp`, to input data, `x`, and verify its contents:

```
x = 15;
xp = libpointer('doublePtr', x);

get(xp)
    Value: 15
    DataType: 'doublePtr'
```

Now call the function and check the results:

```
calllib('shrlibsample', 'multDoubleRef', xp);

get(xp, 'Value')
ans =
    75
```

Note It is important to note that reference `xp` is not a true pointer as it would be in a language like C. That is, even though it was constructed as a reference to `x`, it does not contain the address of `x`. So, when the function executes, it modifies the `Value` property of `xp`, but it does not modify the value in `x`. If you now examine `x`, you find that its original value is unchanged:

```
x
x =
    15
```

Obtaining the Function's Return Values. In the last example, the result of the function called from MATLAB could be obtained by examining the modified input reference. But this function also returns data in its output arguments that may be useful.

The MATLAB prototype for this function (returned by `libfunctions -full`), indicates that MATLAB returns two outputs. The first is an object of class `lib.pointer`; the second is the `Value` property of the `doublePtr` input argument:

```
libfunctions shrlibsample -full
    [lib.pointer, doublePtr] multDoubleRef(doublePtr)
```

Run the example once more, but this time check the output values returned:

```
x = 15;
xp = libpointer('doublePtr', x);

[xobj, xval] = calllib('shrlibsample', 'multDoubleRef', xp)
xobj =
    lib.pointer
xval =
    75
```

Like the input reference argument, the first output, `xobj`, is an object of class `lib.pointer`. You can examine this output, but first you need to initialize its data type and size as these factors are undefined when returned by the function. Use the `setdatatype` method defined by class `lib.pointer` to set the data type to `doublePtr` and the size to 1-by-1.

Once initialized, you can examine the `xobj` output:

```
setdatatype(xobj, 'doublePtr', 1, 1)

get(xobj)
ans =
    Value: 75
    DataType: 'doublePtr'
```

The second output, `xval`, is a double copied from the Value of input `xp`.

Creating a Structure Reference

Creating a reference argument to a structure is not much different than using a reference to a primitive type. The function shown here takes a reference to a structure of type `c_struct` as its only input. It returns an output argument that is the sum of all fields in the structure. It also modifies the fields of the input argument:

```
double addStructByRef(struct c_struct *st)
{
    double t = st->p1 + st->p2 + st->p3;
    st->p1 = 5.5;
    st->p2 = 1234;
    st->p3 = 12345678;
    return t;
}
```

Passing the Structure Itself. Although this function expects to receive a structure reference input, it is easier to pass the structure itself and let MATLAB do the conversion to a reference. This example passes a MATLAB structure, `sm`, to the function `addStructByRef`. MATLAB returns the correct value in the output, `x`, but does not modify the contents of the input, `sm`, since `sm` is not a reference:

```
sm.p1 = 476;    sm.p2 = -299;    sm.p3 = 1000;

x = calllib('shrlibsample', 'addStructByRef', sm)
x =
    1177
```

Passing a Structure Reference. The second part of this example passes the structure by reference. This time, the function receives a pointer to the structure and is then able to modify the structure fields.

```

sp = libpointer('c_struct', sm);
calllib('shrlibsampl', 'addStructByRef', sp)
ans =
    1177

get(sp, 'Value')
ans =
    p1: 5.5000
    p2: 1234
    p3: 12345678

```

Reference Pointers

Arguments that have more than one level of referencing (e.g., `uint16 **`) are referred to here as reference pointers. In MATLAB, these argument types are named with the suffix `PtrPtr` (for example, `uint16PtrPtr`). See the output of `libfunctionsview` or `methods -full` for examples of this type.

When calling a function that takes a reference pointer argument, you can use a reference argument instead and MATLAB will convert it to the reference pointer. For example, the external `allocateStruct` function expects a `c_structPtrPtr` argument:

```

libfunctions shrlibsampl -full
    c_structPtrPtr allocateStruct(c_structPtrPtr)

```

Here is the C function:

```

void allocateStruct(struct c_struct **val)
{
    *val=(struct c_struct*) malloc(sizeof(struct c_struct));
    (*val)->p1 = 12.4;
    (*val)->p2 = 222;
    (*val)->p3 = 333333;
}

```

Although the prototype says that a `c_structPtrPtr` is required, you can use a `c_structPtr` and let MATLAB do the second level of conversion. Create a reference to an empty structure argument and pass it to `allocateStruct`:

```
sp = libpointer('c_structPtr');
calllib('shrllibsample', 'allocateStruct', sp)

get(sp)
ans =
    Value: [1x1 struct]
    DataType: 'c_structPtr'

get(sp, 'Value')
ans =
    p1: 12.4000
    p2: 222
    p3: 333333
```

When you are done, return the memory that you had allocated:

```
calllib('shrllibsample', 'deallocateStruct', sp)
```

Calling C and Fortran Programs from MATLAB

Although MATLAB is a complete, self-contained environment for programming and manipulating data, it is often useful to interact with data and programs external to the MATLAB environment. MATLAB provides an interface to external programs written in the C and Fortran languages.

Introducing MEX-Files (p. 3-2)	Using MEX-files, mx routines, and mex routines
MATLAB Data (p. 3-4)	Data types you can use in MEX-files
Building MEX-Files (p. 3-9)	Compiling and linking your MEX-file
Custom Building MEX-Files (p. 3-18)	Platform-specific instructions on custom building
Troubleshooting (p. 3-28)	Troubleshooting some of the more common problems you may encounter
Additional Information (p. 3-38)	Files you should know about, example programs, where to get help

Introducing MEX-Files

You can call your own C or Fortran subroutines from MATLAB as if they were built-in functions. MATLAB callable C and Fortran programs are referred to as MEX-files. MEX-files are dynamically linked subroutines that the MATLAB interpreter can automatically load and execute.

MEX-files have several applications:

- Large pre-existing C and Fortran programs can be called from MATLAB without having to be rewritten as M-files.
- Bottleneck computations (usually for-loops) that do not run fast enough in MATLAB can be recoded in C or Fortran for efficiency.

MEX-files are not appropriate for all applications. MATLAB is a high-productivity system whose specialty is eliminating time-consuming, low-level programming in compiled languages like Fortran or C. In general, most programming should be done in MATLAB. Don't use the MEX facility unless your application requires it.

Using MEX-Files

MEX-files are subroutines produced from C or Fortran source code. They behave just like M-files and built-in functions. While M-files have a platform-independent extension, `.m`, MATLAB identifies MEX-files by platform-specific extensions. This table lists the platform-specific extensions for MEX-files.

Table 3-1: MEX-File Extensions

Platform	MEX-File Extension
HP-UX	mexhpux
Linux	mexglx
Macintosh	mexmac
Solaris	mexsol
Windows	dll

You can call MEX-files exactly as you would call any M-function. For example, a MEX-file called `conv2.mex` on your disk in the MATLAB `datafun` toolbox directory performs a 2-D convolution of matrices. `conv2.m` only contains the help text documentation. If you invoke the function `conv2` from inside MATLAB, the interpreter looks through the list of directories on the MATLAB search path. It scans each directory looking for the first occurrence of a file named `conv2` with the corresponding filename extension from the table or `.m`. When it finds one, it loads the file and executes it. MEX-files take precedence over M-files when like-named files exist in the same directory. However, help text documentation is still read from the `.m` file.

The Distinction Between `mx` and `mex` Prefixes

Routines in the API that are prefixed with `mx` allow you to create, access, manipulate, and destroy `mxArrays`. Routines prefixed with `mex` perform operations back in the MATLAB environment.

`mx` Routines

The array access and creation library provides a set of array access and creation routines for manipulating MATLAB arrays. These subroutines, which are fully documented in the online API reference pages, always start with the prefix `mx`. For example, `mxGetPi` retrieves the pointer to the imaginary data inside the array.

Although most of the routines in the array access and creation library let you manipulate the MATLAB array, there are two exceptions — the IEEE routines and memory management routines. For example, `mxGetNaN` returns a double, not an `mxArray`.

`mex` Routines

Routines that begin with the `mex` prefix perform operations back in the MATLAB environment. For example, the `mexEvalString` routine evaluates a string in the MATLAB workspace.

Note `mex` routines are only available in MEX-functions.

MATLAB Data

Before you can program MEX-files, you must understand how MATLAB represents the many data types it supports. This section discusses the following topics:

- “The MATLAB Array”
- “Data Storage”
- “Data Types in MATLAB”
- “Using Data Types”

The MATLAB Array

The MATLAB language works with only a single object type: the MATLAB array. All MATLAB variables, including scalars, vectors, matrices, strings, cell arrays, structures, and objects are stored as MATLAB arrays. In C, the MATLAB array is declared to be of type `mxArray`. The `mxArray` structure contains, among other things:

- Its type
- Its dimensions
- The data associated with this array
- If numeric, whether the variable is real or complex
- If sparse, its indices and nonzero maximum elements
- If a structure or object, the number of fields and field names

Data Storage

All MATLAB data is stored columnwise, which is how Fortran stores matrices. MATLAB uses this convention because it was originally written in Fortran. For example, given the matrix

```
a=['house'; 'floor'; 'porch']  
a =  
    house  
    floor  
    porch
```

its dimensions are

```
size(a)
ans =
     3     5
```

and its data is stored as

h	f	p	o	l	o	u	o	r	s	o	c	e	r	h
---	---	---	---	---	---	---	---	---	---	---	---	---	---	---

Data Types in MATLAB

Complex Double-Precision Matrices

The most common data type in MATLAB is the complex double-precision, nonsparse matrix. These matrices are of type `double` and have dimensions `m`-by-`n`, where `m` is the number of rows and `n` is the number of columns. The data is stored as two vectors of double-precision numbers – one contains the real data and one contains the imaginary data. The pointers to this data are referred to as `pr` (pointer to real data) and `pi` (pointer to imaginary data), respectively. A real-only, double-precision matrix is one whose `pi` is `NULL`.

Numeric Matrices

MATLAB also supports other types of numeric matrices. These are single-precision floating-point and 8-, 16-, and 32-bit integers, both signed and unsigned. The data is stored in two vectors in the same manner as double-precision matrices.

Logical Matrices

The logical data type represents a logical true or false state using the numbers 1 and 0, respectively. Certain MATLAB functions and operators return logical 1 or logical 0 to indicate whether a certain condition was found to be true or not. For example, the statement `(5 * 10) > 40` returns a logical 1 value.

MATLAB Strings

MATLAB strings are of type `char` and are stored the same way as unsigned 16-bit integers except there is no imaginary data component. Unlike C, MATLAB strings are not null terminated.

Cell Arrays

Cell arrays are a collection of MATLAB arrays where each `mxAarray` is referred to as a cell. This allows MATLAB arrays of different types to be stored together. Cell arrays are stored in a similar manner to numeric matrices, except the data portion contains a single vector of pointers to `mxAarrays`. Members of this vector are called cells. Each cell can be of any supported data type, even another cell array.

Structures

A 1-by-1 structure is stored in the same manner as a 1-by-`n` cell array where `n` is the number of fields in the structure. Members of the data vector are called fields. Each field is associated with a name stored in the `mxAarray`.

Objects

Objects are stored and accessed the same way as structures. In MATLAB, objects are named structures with registered methods. Outside MATLAB, an object is a structure that contains storage for an additional classname that identifies the name of the object.

Multidimensional Arrays

MATLAB arrays of any type can be multidimensional. A vector of integers is stored where each element is the size of the corresponding dimension. The storage of the data is the same as matrices.

Empty Arrays

MATLAB arrays of any type can be empty. An empty `mxAarray` is one with at least one dimension equal to zero. For example, a double-precision `mxAarray` of type `double`, where `m` and `n` equal 0 and `pr` is `NULL`, is an empty array.

Sparse Matrices

Sparse matrices have a different storage convention than full matrices in MATLAB. The parameters `pr` and `pi` are still arrays of double-precision numbers, but there are three additional parameters, `nzmax`, `ir`, and `jc`:

- `nzmax` is an integer that contains the length of `ir`, `pr`, and, if it exists, `pi`. It is the maximum possible number of nonzero elements in the sparse matrix.
- `ir` points to an integer array of length `nzmax` containing the row indices of the corresponding elements in `pr` and `pi`.
- `jc` points to an integer array of length `N+1` that contains column index information. For `j`, in the range $0 \leq j \leq N-1$, `jc[j]` is the index in `ir` and `pr` (and `pi` if it exists) of the first nonzero entry in the `j`th column and `jc[j+1] - 1` index of the last nonzero entry. As a result, `jc[N]` is also equal to `nnz`, the number of nonzero entries in the matrix. If `nnz` is less than `nzmax`, then more nonzero entries can be inserted in the array without allocating additional storage.

Using Data Types

You can write MEX-files, MAT-file applications, and engine applications in C that accept any data type supported by MATLAB. In Fortran, only the creation of double-precision `n`-by-`m` arrays and strings are supported. You can treat C and Fortran MEX-files, once compiled, exactly like M-functions.

The explore Example

There is an example MEX-file included with MATLAB, called `explore`, that identifies the data type of an input variable. The source file for this example is in the `<matlab>/extern/examples/mex` directory, where `<matlab>` represents the top-level directory where MATLAB is installed on your system.

Note In platform independent discussions that refer to directory paths, this book uses the UNIX convention. For example, a general reference to the `mex` directory is `<matlab>/extern/examples/mex`.

For example, typing

```
cd([matlabroot ' /extern/examples/mex']);  
x = 2;  
explore(x);
```

produces this result

```
-----  
Name: prhs[0]  
Dimensions: 1x1  
Class Name: double  
-----  
(1,1) = 2
```

explore accepts any data type. Try using explore with these examples.

```
explore([1 2 3 4 5])  
explore 1 2 3 4 5  
explore({1 2 3 4 5})  
explore(int8([1 2 3 4 5]))  
explore {1 2 3 4 5}  
explore(sparse(eye(5)))  
explore(struct('name', 'Joe Jones', 'ext', 7332))  
explore(1, 2, 3, 4, 5)
```

Building MEX-Files

This section covers the following topics:

- “Compiler Requirements”
- “Testing Your Configuration on UNIX”
- “Testing Your Configuration on Windows”
- “Specifying an Options File”

Compiler Requirements

Your installed version of MATLAB contains all the tools you need to work with the API. MATLAB includes a C compiler for the PC called Lcc, but does not include a Fortran compiler. If you choose to use your own C compiler, it must be an ANSI C compiler. Also, if you are working on a Microsoft Windows platform, your compiler must be able to create 32-bit windows dynamically linked libraries (DLLs).

MATLAB supports many compilers and provides preconfigured files, called options files, designed specifically for these compilers. The Options Files table lists all supported compilers and their corresponding options files. The purpose of supporting this large collection of compilers is to provide you with the flexibility to use the tool of your choice. However, in many cases, you simply can use the provided Lcc compiler with your C code to produce your applications.

The MathWorks also maintains a list of compilers supported by MATLAB at the following location on the web:

<http://www.mathworks.com/support/tech-notes/1600/1601.shtml>.

Note The MathWorks provides an option (setup) for the mex script that lets you easily choose or switch your compiler.

The following sections contain configuration information for creating MEX-files on UNIX and Windows systems. More detailed information about the mex script is provided in “Custom Building MEX-Files” on page 3-18. In addition, there is a section on “Troubleshooting” on page 3-28, if you are having difficulties creating MEX-files.

Testing Your Configuration on UNIX

The quickest way to check if your system is set up properly to create MEX-files is by trying the actual process. There is C source code for an example, `yprime.c`, and its Fortran counterpart, `yprimef.F` and `yprimefg.F`, included in the `<matlab>/extern/examples/mex` directory, where `<matlab>` represents the top-level directory where MATLAB is installed on your system.

To compile and link the example source files, `yprime.c` or `yprimef.F` and `yprimefg.F`, on UNIX, you must first copy the file(s) to a local directory, and then change directory (`cd`) to that local directory.

At the MATLAB prompt, type

```
mex yprime.c
```

This uses the system compiler to create the MEX-file called `yprime` with the appropriate extension for your system.

You can now call `yprime` as if it were an M-function.

```
yprime(1,1:4)
ans =
    2.0000    8.9685    4.0000   -1.0947
```

To try the Fortran version of the sample program with your Fortran compiler, at the MATLAB prompt, type

```
mex yprimef.F yprimefg.F
```

In addition to running the `mex` script from the MATLAB prompt, you can also run the script from the system prompt.

Selecting a Compiler

To change your default compiler, you select a different options file. You can do this anytime by using the command

```
mex -setup
```

Using the `'mex -setup'` command selects an options file that is placed in `~/matlab` and used by default for `'mex'`. An options file in the current working directory or specified on the command line overrides the default options file in `~/matlab`.

Options files control which compiler to use, the compiler and link command options, and the runtime libraries to link against.

To override the default options file, use the 'mex -f' command (see 'mex -help' for more information).

The options files available for mex are:

- 1: <matlab>/bin/gccopts.sh :
 Template Options file for building gcc MEXfiles
- 2: <matlab>/bin/mexopts.sh :
 Template Options file for building MEXfiles using the
 system ANSI compiler

Enter the number of the options file to use as your default options file:

Select the proper options file for your system by entering its number and pressing **Return**. If an options file doesn't exist in your MATLAB directory, the system displays a message stating that the options file is being copied to your user-specific matlab directory. If an options file already exists in your matlab directory, the system prompts you to overwrite it.

Note The setup option creates a user-specific matlab directory in your individual home directory and copies the appropriate options file to the directory. (If the directory already exists, a new one is not created.) This matlab directory is used for your individual options files only; each user can have his or her own default options files (other MATLAB products may place options files in this directory). Do not confuse these user-specific matlab directories with the system matlab directory, where MATLAB is installed. To see the name of this directory on your machine, use the MATLAB command `prefdir`.

Using the setup option resets your default compiler so that the new compiler is used every time you use the mex script.

Testing Your Configuration on Windows

Before you can create MEX-files on the Windows platform, you must configure the default options file, `mexopts.bat`, for your compiler. The switch, `setup`, provides an easy way for you to configure the default options file. To configure or change the options file at anytime, run

```
mex -setup
```

from either the MATLAB or DOS command prompt.

Selecting a Compiler

MATLAB includes a C compiler, `Lcc`, that you can use to create C MEX-files. The `mex` script will use the `Lcc` compiler automatically if you do not have a C or C++ compiler of your own already installed on your system and you try to compile a C MEX-file. Naturally, if you need to compile Fortran programs, you must supply your own supported Fortran compiler.

The `mex` script uses the filename extension to determine the type of compiler to use for creating your MEX-files. For example,

```
mex test1.f
```

would use your Fortran compiler and

```
mex test2.c
```

would use your C compiler.

On Systems without a Compiler. If you do not have your own C or C++ compiler on your system, the `mex` utility automatically configures itself for the included `Lcc` compiler. So, to create a C MEX-file on these systems, you can simply enter

```
mex filename.c
```

This simple method of creating MEX-files works for the majority of users.

If using the included `Lcc` compiler satisfies your needs, you can skip ahead in this section to “Building the MEX-File on Windows” on page 3-14.

On Systems with a Compiler. On systems where there is a C, C++, or Fortran compiler, you can select which compiler you want to use. Once you choose your compiler, that compiler becomes your default compiler and you no longer have

to select one when you compile MEX-files. To select a compiler or change to existing default compiler, use `mex setup`.

This example shows the process of setting your default compiler to the Microsoft Visual C++ Version 6.0 compiler.

```
mex -setup
```

```
Please choose your compiler for building external interface (MEX) files.
```

```
Would you like mex to locate installed compilers [y]/n? n
```

```
Select a compiler:
```

```
[1] Compaq Visual Fortran version 6.6
```

```
[2] Lcc C version 2.4
```

```
[3] Microsoft Visual C/C++ version 6.0
```

```
[0] None
```

```
Compiler: 3
```

```
Your machine has a Microsoft Visual C/C++ compiler located at D:\Applications\Microsoft Visual Studio. Do you want to use this compiler [y]/n? y
```

```
Please verify your choices:
```

```
Compiler: Microsoft Visual C/C++ 6.0
```

```
Location: C:\Program Files\Microsoft Visual Studio
```

```
Are these correct?([y]/n): y
```

```
The default options file:
```

```
"C:\WINNT\Profiles\username\ApplicationData\MathWorks\MATLAB\R13\nexopts.bat" is being updated from ...
```

If the specified compiler cannot be located, you are given the message:

```
The default location for compiler-name is directory-name,  
but that directory does not exist on this machine.
```

```
Use directory-name anyway [y]/n?
```

Using the `setup` option sets your default compiler so that the new compiler is used every time you use the `mex` script.

Building the MEX-File on Windows

There is example C source code, `yprime.c`, and its Fortran counterpart, `yprimef.f` and `yprimefg.f`, included in the `<matlab>\extern\examples\mex` directory, where `<matlab>` represents the top-level directory where MATLAB is installed on your system.

To compile and link the example source file on Windows, at the MATLAB prompt, type

```
cd([matlabroot '\extern\examples\mex'])  
mex yprime.c
```

This should create the MEX-file called `yprime` with the `.DLL` extension, which corresponds to the Windows platform.

You can now call `yprime` as if it were an M-function.

```
yprime(1,1:4)  
ans =  
    2.0000    8.9685    4.0000   -1.0947
```

To try the Fortran version of the sample program with your Fortran compiler, switch to your Fortran compiler using `mex -setup`. Then, at the MATLAB prompt, type

```
cd([matlabroot '\extern\examples\mex'])  
mex yprimef.f yprimefg.f
```

In addition to running the `mex` script from the MATLAB prompt, you can also run the script from the system prompt.

Specifying an Options File

You can use the `-f` option to specify an options file on either UNIX or Windows. To use the `-f` option, at the MATLAB prompt type

```
mex filename -f <optionsfile>
```

and specify the name of the options file along with its pathname. The Options Files table, below, contains a list of the options files included with MATLAB.

There are several situations when it may be necessary to specify an options file every time you use the `mex` script. These include:

- (*Windows and UNIX*) You want to use a different compiler (and not use the `-setup` option), or you want to compile MAT or engine stand-alone programs.
- (*UNIX*) You do not want to use the system C compiler.

Preconfigured Options Files

MATLAB includes some preconfigured options files that you can use with particular compilers. The Options Files table lists the compilers whose options files are included with this release of MATLAB.

Table 3-2: Options Files

Platform	Compiler	Options File
Windows	Borland C++, Version 5.0 & 5.2	bccopts.bat
	Borland C++Builder 3.0 (Borland C++, Version 5.3)	bcc53opts.bat
	Borland C++Builder 4.0 (Borland C++, Version 5.4)	bcc54opts.bat
	Borland C++Builder 5.0 (Borland C++, Version 5.5)	bcc55opts.bat
	Lcc C Compiler, bundled with MATLAB	lccopts.bat
	Microsoft C/C++, Version 5.0	msvc50opts.bat

Table 3-2: Options Files (Continued)

Platform	Compiler	Options File
	Microsoft C/C++, Version 6.0	msvc60opts.bat
	Watcom C/C++, Version 11	wat11copts.bat
	DIGITAL Visual Fortran, Version 5.0	df50opts.bat
	Compaq Visual Fortran, Version 6.1	df61opts.bat
	Compaq Visual Fortran, Version 6.6	df66opts.bat
	Borland C, Version 5.0 & 5.2, for Engine and MAT stand-alone programs	bccengmatopts.bat
	Borland C, Version 5.3, for Engine and MAT stand-alone programs	bcc53engmatopts.bat
	Borland C, Version 5.4, for Engine and MAT stand-alone programs	bcc54engmatopts.bat
	Borland C, Version 5.5, for Engine and MAT stand-alone programs	bcc55engmatopts.bat
	Lcc C compiler for Engine and MAT stand-alone programs,	lccengmatopts.bat
	Microsoft Visual C for Engine and MAT stand-alone programs, Version 5.0	msvc50engmatopts.bat
	Microsoft Visual C for Engine and MAT stand-alone programs, Version 6.0	msvc60engmatopts.bat
	Watcom C for Engine and MAT stand-alone programs, Version 11	wat11engmatopts.bat

Table 3-2: Options Files (Continued)

Platform	Compiler	Options File
	DIGITAL Visual Fortran for MAT stand-alone programs, Version 5.0	df50engmatopts.bat
	Compaq Visual Fortran for MAT stand-alone programs, Version 6.1	df60engmatopts.bat
UNIX	System ANSI Compiler	mexopts.sh
	GCC	gccopts.sh
	System ANSI Compiler for Engine stand-alone programs	engopts.sh
	System ANSI Compiler for MAT stand-alone programs	matopts.sh

An up-to-date list of options files is available from our FTP server, <ftp://ftp.mathworks.com/pub/tech-support/docexamples/apiguide/R12/bin>. For a list of all the compilers supported by MATLAB, access the MathWorks Technical Support Web site at <http://www.mathworks.com/support>.

Note The next section, “Custom Building MEX-Files” on page 3-18, contains specific information on how to modify options files for particular systems.

Custom Building MEX-Files

This section discusses in detail the process that the MEX-file build script uses. It covers the following topics:

- “Who Should Read this Chapter”
- “MEX Script Switches”
- “Default Options File on UNIX”
- “Default Options File on Windows”
- “Custom Building on UNIX”
- “Custom Building on Windows”

Who Should Read this Chapter

In general, the defaults that come with MATLAB should be sufficient for building most MEX-files. There are reasons that you might need more detailed information, such as:

- You want to use an Integrated Development Environment (IDE), rather than the provided script, to build MEX-files.
- You want to create a new options file, for example, to use a compiler that is not directly supported.
- You want to exercise more control over the build process than the script uses.

The script, in general, uses two stages (or three, for Microsoft Windows) to build MEX-files. These are the compile stage and the link stage. In between these two stages, Windows compilers must perform some additional steps to prepare for linking (the prelink stage).

MEX Script Switches

The mex script has a set of switches (also called options) that you can use to modify the link and compile stages. The MEX Script Switches table lists the available switches and their uses. Each switch is available on both UNIX and Windows unless otherwise noted.

For customizing the build process, you should modify the options file, which contains the compiler-specific flags corresponding to the general compile, prelink, and link steps required on your system. The options file consists of a

series of variable assignments; each variable represents a different logical piece of the build process.

Table 3-3: MEX Script Switches

Switch	Function
@<rsp_file>	Include the contents of the text file <rsp_file> as command line arguments to the mex script.
-argcheck	Perform argument checking on MATLAB API functions (C functions only).
-c	Compile only; do not link.
-D<name>[#<def>]	Define C preprocessor macro <name> [as having value <def>]. (Note: UNIX also allows -D<name>[=<def>].)
-f <file>	Use <file> as the options file; <file> is a full pathname if it is not in current directory.
-g	Build an executable with debugging symbols included.
-h[elp]	Help; lists the switches and their functions.
-I<pathname>	Include <pathname> in the compiler include search path.
-inline	Inlines matrix accessor functions (mx*). The generated MEX-function may not be compatible with future versions of MATLAB.
-l<file>	(UNIX) Link against library lib<file>.
-L<pathname>	(UNIX) Include <pathname> in the list of directories to search for libraries.

Table 3-3: MEX Script Switches (Continued)

Switch	Function
<name>#<def>	Override options file setting for variable <name>. This option is equivalent to <ENV_VAR>#<val>, which temporarily sets the environment variable <ENV_VAR> to <val> for the duration of the call to mex. <val> can refer to another environment variable by prepending the name of the variable with a \$, e.g., COMPFLAGS#\$COMPFLAGS -myswitch".
<name>=<def>	(UNIX) Override options file setting for variable <name>.
-O	Build an optimized executable.
-outdir <name>	Place all output files in directory <name>.
-output <name>	Create an executable named <name>. (An appropriate executable extension is automatically appended.)
-setup	Set up default options file. This switch should be the only argument passed.
-U<name>	Undefine C preprocessor macro <name>.
-v	Verbose; print all compiler and linker settings.
-V5	Compile MATLAB 5-compatible MEX-file.

Default Options File on UNIX

The default MEX options file provided with MATLAB is located in <matlab>/bin. The mex script searches for an options file called mexopts.sh in the following order:

- The current directory
- The directory returned by the prefdir function
- The directory specified by [matlabroot '/bin']

`mex` uses the first occurrence of the options file it finds. If no options file is found, `mex` displays an error message. You can directly specify the name of the options file using the `-f` switch.

For specific information on the default settings for the MATLAB supported compilers, you can examine the options file in `fullfile(matlabroot, 'bin', 'mexopts.sh')`, or you can invoke the `mex` script in verbose mode (`-v`). Verbose mode will print the exact compiler options, prelink commands (if appropriate), and linker options used in the build process for each compiler. “Custom Building on UNIX” on page 3-22 gives an overview of the high-level build process.

Default Options File on Windows

The default MEX options file is placed in your user profile directory after you configure your system by running `mex -setup`. The `mex` script searches for an options file called `mexopts.bat` in the following order:

- The current directory
- The user profile directory (returned by the `prefdir` function)
- The directory specified by `[matlabroot '\bin\win32\mexopts']`

`mex` uses the first occurrence of the options file it finds. If no options file is found, `mex` searches your machine for a supported C compiler and automatically configures itself to use that compiler. Also, during the configuration process, it copies the compiler’s default options file to the user profile directory. If multiple compilers are found, you are prompted to select one.

For specific information on the default settings for the MATLAB supported compilers, you can examine the options file, `mexopts.bat`, or you can invoke the `mex` script in verbose mode (`-v`). Verbose mode will print the exact compiler options, prelink commands, if appropriate, and linker options used in the build process for each compiler. “Custom Building on Windows” on page 3-24 gives an overview of the high-level build process.

The User Profile Directory

The Windows user profile directory is a directory that contains user-specific information such as desktop appearance, recently used files, and **Start** menu items. The `mex` and `mbuild` utilities store their respective options files, `mexopts.bat` and `compopts.bat`, which are created during the `setup` process,

in a subdirectory of your user profile directory, named Application Data\MathWorks\MATLAB.

Custom Building on UNIX

On UNIX systems, there are two stages in MEX-file building: compiling and linking.

Compile Stage

The compile stage must:

- Add `<matlab>/extern/include` to the list of directories in which to find header files (`-I<matlab>/extern/include`)
- Define the preprocessor macro `MATLAB_MEX_FILE` (`-DMATLAB_MEX_FILE`)
- (C MEX-files only) Compile the source file, which contains version information for the MEX-file, `<matlab>/extern/src/mexversion.c`

Link Stage

The link stage must:

- Instruct the linker to build a shared library
- Link all objects from compiled source files (including `mexversion.c`)
- (Fortran MEX-files only) Link in the precompiled versioning source file, `<matlab>/extern/lib/$Arch/version4.o`
- Export the symbols `mexFunction` and `mexVersion` (these symbols represent functions called by MATLAB)

For Fortran MEX-files, the symbols are all lower case and may have appended underscores. For specific information, invoke the `mex` script in verbose mode and examine the output.

Build Options

For customizing the build process, you should modify the options file. The options file contains the compiler-specific flags corresponding to the general steps outlined above. The options file consists of a series of variable assignments; each variable represents a different logical piece of the build process. The options files provided with MATLAB are located in `<matlab>/bin`.

The section, “Default Options File on UNIX” on page 3-20, describes how the `mex` script looks for an options file.

To aid in providing flexibility, there are two sets of options in the options file that can be turned on and off with switches to the `mex` script. These sets of options correspond to building in *debug mode* and building in *optimization mode*. They are represented by the variables `DEBUGFLAGS` and `OPTIMFLAGS`, respectively, one pair for each *driver* that is invoked (`CDEBUGFLAGS` for the C compiler, `FDEBUGFLAGS` for the Fortran compiler, and `LDDEBUGFLAGS` for the linker; similarly for the `OPTIMFLAGS`).

- If you build in optimization mode (the default), the `mex` script will include the `OPTIMFLAGS` options in the compile and link stages.
- If you build in debug mode, the `mex` script will include the `DEBUGFLAGS` options in the compile and link stages, but will not include the `OPTIMFLAGS` options.
- You can include both sets of options by specifying both the optimization and debugging flags to the `mex` script (`-O` and `-g`, respectively).

Aside from these special variables, the `mex` options file defines the executable invoked for each of the three modes (C compile, Fortran compile, link) and the flags for each stage. You can also provide explicit lists of libraries that must be linked in to all MEX-files containing source files of each language.

The variables can be summed up as follows.

Variable	C Compiler	Fortran Compiler	Linker
Executable	CC	FC	LD
Flags	CFLAGS	FFLAGS	LDLFLAGS
Optimization	COPTIMFLAGS	FOPTIMFLAGS	LDOPTIMFLAGS
Debugging	CDEBUGFLAGS	FDEBUGFLAGS	LDDEBUGFLAGS
Additional libraries	CLIBS	FLIBS	(none)

For specifics on the default settings for these variables, you can:

- Examine the options file in `<matlab>/bin/mexopts.sh` (or the options file you are using), or
- Invoke the `mex` script in verbose mode

Custom Building on Windows

There are three stages to MEX-file building for both C and Fortran on Windows – compiling, prelinking, and linking.

Compile Stage

For the compile stage, a `mex` options file must:

- Set up paths to the compiler using the `COMPILER` (e.g., Watcom), `PATH`, `INCLUDE`, and `LIB` environment variables. If your compiler always has the environment variables set (e.g., in `AUTOEXEC.BAT`), you can remark them out in the options file.
- Define the name of the compiler, using the `COMPILER` environment variable, if needed.
- Define the compiler switches in the `COMPFLAGS` environment variable.
 - **a** The switch to create a DLL is required for MEX-files.
 - **b** For stand-alone programs, the switch to create an exe is required.
 - **c** The `-c` switch (compile only; do not link) is recommended.
 - **d** The switch to specify 8-byte alignment.
 - **e** Any other switch specific to the environment can be used.
- Define preprocessor macro, with `-D`, `MATLAB_MEX_FILE` is required.
- Set up optimizer switches and/or debug switches using `OPTIMFLAGS` and `DEBUGFLAGS`. These are mutually exclusive: the `OPTIMFLAGS` are the default, and the `DEBUGFLAGS` are used if you set the `-g` switch on the `mex` command line.

Prelink Stage

The prelink stage dynamically creates import libraries to import the required function into the MEX, MAT, or engine file:

- All MEX-files link against MATLAB only.
- MAT stand-alone programs link against `libmx.dll` (array access library), `libut.dll` (utility library), and `libmat.dll` (MAT-functions).
- Engine stand-alone programs link against `libmx.dll` (array access library), `libut.dll` (utility library), and `libeng.dll` for engine functions.

MATLAB and each DLL have corresponding `.def` files of the same names located in the `<matlab>\extern\include` directory.

Link Stage

Finally, for the link stage, a mex options file must:

- Define the name of the linker in the `LINKER` environment variable.
- Define the `LINKFLAGS` environment variable that must contain:
 - The switch to create a DLL for MEX-files, or the switch to create an exe for stand-alone programs.
 - Export of the entry point to the MEX-file as `mexFunction` for C or `MEXFUNCTION@16` for DIGITAL Visual Fortran.
 - The import library (or libraries) created in the `PRELINK_CMDS` stage.
 - Any other link switch specific to the compiler that can be used.
- Define the linking optimization switches and debugging switches in `LINKEROPTIMFLAGS` and `LINKDEBUGFLAGS`. As in the compile stage, these two are mutually exclusive: the default is optimization, and the `-g` switch invokes the debug switches.
- Define the link-file identifier in the `LINK_FILE` environment variable, if needed. For example, Watcom uses `file` to identify that the name following is a file and not a command.
- Define the link-library identifier in the `LINK_LIB` environment variable, if needed. For example, Watcom uses `library` to identify the name following is a library and not a command.
- Optionally, set up an output identifier and name with the output switch in the `NAME_OUTPUT` environment variable. The environment variable `MEX_NAME`

contains the name of the first program in the command line. This must be set for `-output` to work. If this environment is not set, the compiler default is to use the name of the first program in the command line. Even if this is set, it can be overridden by specifying the `mex -output` switch.

Linking DLLs to MEX-Files

To link a DLL to a MEX-file, list the DLL's `.lib` file on the command line.

Versioning MEX-Files

The `mex` script can build your MEX-file with a resource file that contains versioning and other essential information. The resource file is called `mexversion.rc` and resides in the `extern\include` directory. To support versioning, there are two new commands in the options files, `RC_COMPILER` and `RC_LINKER`, to provide the resource compiler and linker commands. It is assumed that:

- If a compiler command is given, the compiled resource will be linked into the MEX-file using the standard link command.
- If a linker command is given, the resource file will be linked to the MEX-file after it is built using that command.

Compiling MEX-Files with the Microsoft Visual C++ IDE

Note This section provides information on how to compile MEX-files in the Microsoft Visual C++ (MSVC) IDE; it is not totally inclusive. This section assumes that you know how to use the IDE. If you need more information on using the MSVC IDE, refer to the corresponding Microsoft documentation.

To build MEX-files with the Microsoft Visual C++ integrated development environment:

- 1 Create a project and insert your MEX source and `mexversion.rc` into it.
- 2 Create a `.DEF` file to export the MEX entry point. For example

```
LIBRARY MYFILE.DLL
EXPORTS mexFunction          <-- for a C MEX-file
or
```



```
EXPORTS _MEXFUNCTION@16      <-- for a Fortran MEX-file
```

- 3 Add the .DEF file to the project.
- 4 Locate the .LIB files for the compiler version you are using under matlabroot\extern\lib\win32\microsoft. For example, for version 6.0, these files are in the msvc60 subdirectory.
- 5 From this directory, add libmx.lib, libmex.lib, and libmat.lib to the library modules in the LINK settings option.
- 6 Add the MATLAB include directory, MATLAB\EXTERN\INCLUDE to the include path in the **Settings C/C++ Preprocessor** option.
- 7 Add MATLAB_MEX_FILE to the **C/C++ Preprocessor** option by selecting **Settings** from the **Build** menu, selecting **C/C++**, and then typing ,MATLAB_MEX_FILE after the last entry in the **Preprocessor definitions** field.
- 8 To debug the MEX-file using the IDE, put MATLAB.EXE in the **Settings Debug** option as the **Executable for debug session**.

If you are using a compiler other than the Microsoft Visual C/C++ compiler, the process for building MEX files is similar to that described above. In step 4, locate the .LIB files for the compiler you are using in a subdirectory of matlabroot\extern\lib\win32. For example, for version 5.4 of the Borland C/C++ compiler, look in matlabroot\extern\lib\win32\borland\bc54.

Troubleshooting

This section explains how to troubleshoot some of the more common problems you may encounter. It addresses the following topics:

- “Configuration Issues”
- “Understanding MEX-File Problems”
- “Compiler and Platform-Specific Issues”
- “Memory Management Compatibility Issues”

Configuration Issues

This section focuses on some common problems that might occur when creating MEX-files.

Search Path Problem on Windows

Under Windows, if you move the MATLAB executable without reinstalling MATLAB, you may need to modify `mex.bat` to point to the new MATLAB location.

MATLAB Pathnames Containing Spaces on Windows

If you have problems building MEX-files on Windows and there is a space in any of the directory names within the MATLAB path, you need to either reinstall MATLAB into a pathname that contains no spaces or rename the directory that contains the space. For example, if you install MATLAB under the Program Files directory, you may have difficulty building MEX-files with certain C compilers.

DLLs Not on Path on Windows

MATLAB will fail to load MEX-files if it cannot find all DLLs referenced by the MEX-file; the DLLs must be on the DOS path or in the same directory as the MEX-file. This is also true for third-party DLLs.

Internal Error When Using mex -setup (PC).

Some antivirus software packages may conflict with the mex -setup process or other mex commands. If you get an error message of the following form in response to a mex command,

```
mex.bat: internal error in sub get_compiler_info(): don't  
recognize <string>
```

then you need to disable your antivirus software temporarily and reenter the command. After you have successfully run the mex operation, you can re-enable your antivirus software.

Alternatively, you can open a separate MS-DOS window and enter the mex command from that window.

General Configuration Problem

Make sure you followed the configuration steps for your platform described in this chapter. Also, refer to “Custom Building MEX-Files” on page 3-18 for additional information.

Understanding MEX-File Problems

This section contains information regarding common problems that occur when creating MEX-files. Use the figure, below, to help isolate these problems.

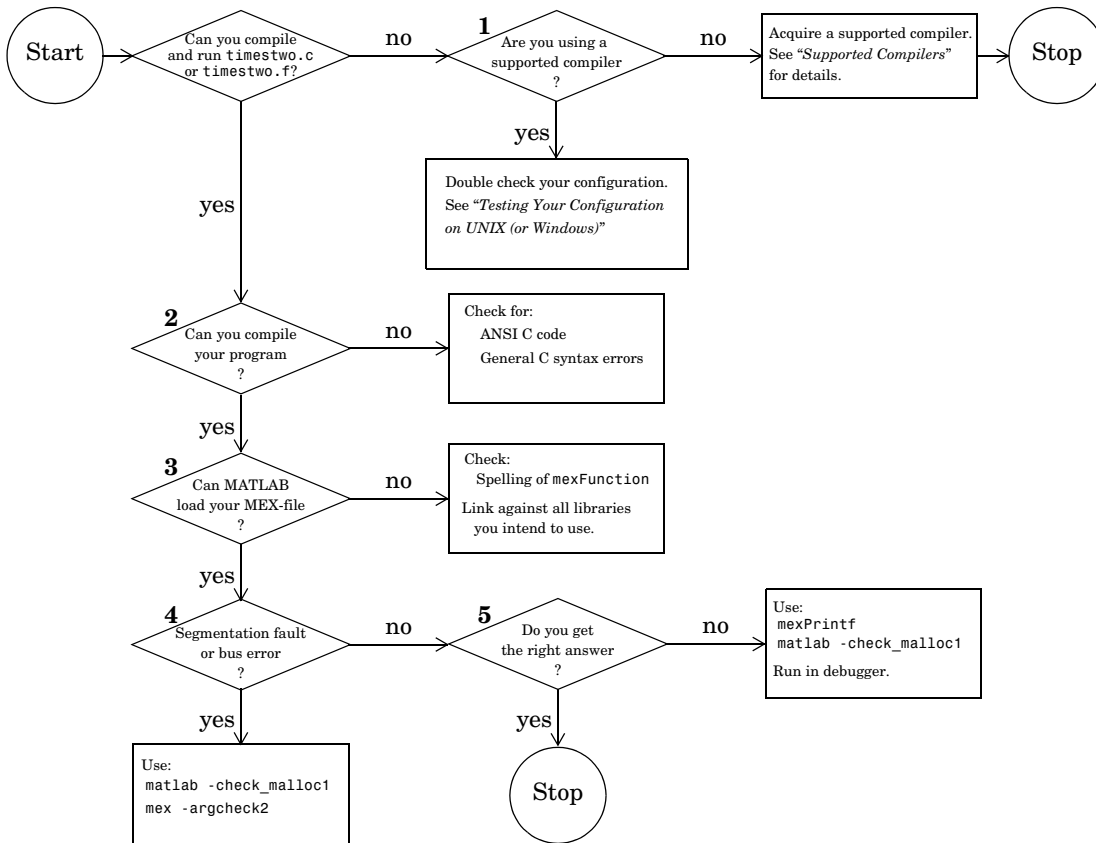

¹ UNIX only

² MEX-files only

Figure 3-1: Troubleshooting MEX-File Creation Problems

Problems 1 through 5 refer to specific sections of the previous flowchart. For additional suggestions on resolving MEX build problems, access the MathWorks Technical Support Web site at <http://www.mathworks.com/support>.

Problem 1 - Compiling a MathWorks Program Fails

The most common configuration problem in creating C MEX-files on UNIX involves using a non-ANSI C compiler, or failing to pass to the compiler a flag that tells it to compile ANSI C code.

A reliable way of knowing if you have this type of configuration problem is if the header files supplied by The MathWorks generate a string of syntax errors when you try to compile your code. See “Building MEX-Files” on page 3-9 for information on selecting the appropriate options file or, if necessary, obtain an ANSI C compiler.

Problem 2 - Compiling Your Own Program Fails

A second way of generating a string of syntax errors occurs when you attempt to mix ANSI and non-ANSI C code. The MathWorks provides header and source files that are ANSI C compliant. Therefore, your C code must also be ANSI compliant.

Other common problems that can occur in any C program are neglecting to include all necessary header files, or neglecting to link against all required libraries.

Problem 3 - MEX-File Load Errors

If you receive an error of the form

```
Unable to load mex file:  
??? Invalid MEX-file
```

MATLAB is unable to recognize your MEX-file as being valid.

MATLAB loads MEX-files by looking for the gateway routine, `mexFunction`. If you misspell the function name, MATLAB is not able to load your MEX-file and generates an error message. On Windows, check that you are exporting `mexFunction` correctly.

On some platforms, if you fail to link against required libraries, you may get an error when MATLAB loads your MEX-file rather than when you compile your

MEX-file. In such cases, you see a system error message referring to *unresolved symbols* or *unresolved references*. Be sure to link against the library that defines the function in question.

On Windows, MATLAB will fail to load MEX-files if it cannot find all DLLs referenced by the MEX-file; the DLLs must be on the path or in the same directory as the MEX-file. This is also true for third party DLLs.

Problem 4 - Segmentation Fault or Bus Error

If your MEX-file causes a segmentation violation or bus error, it means that the MEX-file has attempted to access protected, read-only, or unallocated memory. Since this is such a general category of programming errors, such problems are sometimes difficult to track down.

Segmentation violations do not always occur at the same point as the logical errors that cause them. If a program writes data to an unintended section of memory, an error may not occur until the program reads and interprets the corrupted data. Consequently, a segmentation violation or bus error can occur after the MEX-file finishes executing.

MATLAB provides three features to help you in troubleshooting problems of this nature. Listed in order of simplicity, they are:

- **Recompile your MEX-file with argument checking (C MEX-files only).** You can add a layer of error checking to your MEX-file by recompiling with the mex script flag `-argcheck`. This warns you about invalid arguments to both MATLAB MEX-file (`mex`) and matrix access (`mx`) API functions. Although your MEX-file will not run as efficiently as it can, this switch detects such errors as passing null pointers to API functions.
- **Run MATLAB with the `-check_malloc` option (UNIX only).** The MATLAB startup flag, `-check_malloc`, indicates that MATLAB should maintain additional memory checking information. When memory is freed, MATLAB checks to make sure that memory just before and just after this memory remains unwritten and that the memory has not been previously freed. If an error occurs, MATLAB reports the size of the allocated memory block. Using this information, you can track down where in your code this memory was allocated, and proceed accordingly.

Although using this flag prevents MATLAB from running as efficiently as it can, it detects such errors as writing past the end of a dimensioned array, or freeing previously freed memory.

- **Run MATLAB within a debugging environment.** This process is already described in the chapters on creating C and Fortran MEX-files, respectively.

Problem 5 - Program Generates Incorrect Results

If your program generates the wrong answer(s), there are several possible causes. First, there could be an error in the computational logic. Second, the program could be reading from an uninitialized section of memory. For example, reading the 11th element of a 10-element vector yields unpredictable results.

Another possibility for generating a wrong answer could be overwriting valid data due to memory mishandling. For example, writing to the 15th element of a 10-element vector might overwrite data in the adjacent variable in memory. This case can be handled in a similar manner as segmentation violations as described in Problem 4.

In all of these cases, you can use `mexPrintf` to examine data values at intermediate stages, or run MATLAB within a debugger to exploit all the tools the debugger provides.

Compiler and Platform-Specific Issues

This section refers to situations specific to particular compilers and platforms.

MEX-Files Created in Watcom IDE

If you use the Watcom IDE to create MEX-files and get unresolved references to API functions when linking against our libraries, check the argument passing convention. The Watcom IDE uses a default switch that passes parameters in registers. MATLAB requires that you pass parameters on the stack.

Memory Management Compatibility Issues

MATLAB now implicitly calls `mxDestroyArray`, the `mxArray` destructor, at the end of a MEX-file's execution on any `mxArrays` that are not returned in the left-hand side list (`p1hs[]`). MATLAB issues a warning when it detects any misconstructed or improperly destructed `mxArrays`.

We highly recommend that you fix code in your MEX-files that produces any of the warnings discussed in the following sections. For additional information, see “Memory Management” on page 4-37 in *Creating C Language MEX-Files*.

Note Currently, the following warnings are enabled by default for backwards compatibility reasons. In future releases of MATLAB, the warnings will be disabled by default. The programmer will be responsible for enabling these warnings during the MEX-file development cycle.

Improperly Destroying an mxArray

You cannot use `mxFree` to destroy an mxArray.

Warning

Warning: You are attempting to call `mxFree` on a <class-id> array. The destructor for mxArray is `mxDestroyArray`; please call this instead. MATLAB will attempt to fix the problem and continue, but this will result in memory faults in future releases.

Example That Causes Warning

In the following example, `mxFree` does not destroy the array object. This operation frees the structure header associated with the array, but MATLAB will still operate as if the array object needs to be destroyed. Thus MATLAB will try to destroy the array object, and in the process, attempt to free its structure header again.

```
mxArray *temp = mxCreateDoubleMatrix(1,1,mxREAL);
...
mxFree(temp); /* INCORRECT */
```

Solution

Call `mxDestroyArray` instead.

```
mxDestroyArray(temp); /* CORRECT */
```

Incorrectly Constructing a Cell or Structure mxArray

You cannot call `mxSetCell` or `mxSetField` variants with `prhs[]` as the member array.

Warning

Warning: You are attempting to use an array from another scope (most likely an input argument) as a member of a cell array or structure. You need to make a copy of the array first. MATLAB will attempt to fix the problem and continue, but this will result in memory faults in future releases.

Example That Causes Warning

In the following example, when the MEX-file returns, MATLAB will destroy the entire cell array. Since this includes the members of the cell, this will implicitly destroy the MEX-file's input arguments. This can cause several strange results, generally having to do with the corruption of the caller's workspace, if the right-hand side argument used is a temporary array (i.e., a literal or the result of an expression).

```
myfunction('hello')
/* myfunction is the name of your MEX-file and your code */
/* contains the following: */

    mxArray *temp = mxCreateCellMatrix(1,1);
    ...
    mxSetCell(temp, 0, prhs[0]); /* INCORRECT */
```

Solution

Make a copy of the right-hand side argument with `mxDuplicateArray` and use that copy as the argument to `mxSetCell` (or `mxSetField` variants); for example

```
    mxSetCell(temp, 0, mxDuplicateArray(prhs[0])); /* CORRECT */
```

Creating a Temporary mxArray with Improper Data

You cannot call `mxDestroyArray` on an mxArray whose data was not allocated by an API routine.

Warning

Warning: You have attempted to point the data of an array to a block of memory not allocated through the MATLAB API. MATLAB will attempt to fix the problem and continue, but this will result in memory faults in future releases.

Example That Causes Warning

If you call `mxSetPr`, `mxSetPi`, `mxSetData`, or `mxSetImagData`, specifying memory that was not allocated by `mxCalloc`, `mxMalloc`, or `mxRealloc` as the intended data block (second argument), then when the MEX-file returns, MATLAB will attempt to free the pointer to real data and the pointer to imaginary data (if any). Thus MATLAB will attempt to free memory, in this example, from the program stack. This will cause the above warning when MATLAB attempts to reconcile its consistency checking information.

```
mxArray *temp = mxCreateDoubleMatrix(0,0,mxREAL);
double data[5] = {1,2,3,4,5};
...
mxSetM(temp,1); mxSetN(temp,5); mxSetPr(temp, data);
/* INCORRECT */
```

Solution

Rather than use `mxSetPr` to set the data pointer, instead create the `mxArray` with the right size and use `memcpy` to copy the stack data into the buffer returned by `mxGetPr`.

```
mxArray *temp = mxCreateDoubleMatrix(1,5,mxREAL);
double data[5] = {1,2,3,4,5};
...
memcpy(mxGetPr(temp), data, 5*sizeof(double)); /* CORRECT */
```

Potential Memory Leaks

Prior to Version 5.2, if you created an `mxArray` using one of the API creation routines and then you overwrote the pointer to the data using `mxSetPr`, MATLAB would still free the original memory. This is no longer the case.

For example,

```
pr = mxCalloc(5*5, sizeof(double));
... <load data into pr>
plhs[0] = mxCreateDoubleMatrix(5,5,mxREAL);
mxSetPr(plhs[0], pr); /* INCORRECT */
```

will now leak $5*5*8$ bytes of memory, where 8 bytes is the size of a double.

You can avoid that memory leak by changing the code

```
plhs[0] = mxCreateDoubleMatrix(5,5,mxREAL);
pr = mxGetPr(plhs[0]);
... <load data into pr>
```

or alternatively

```
pr = mxCalloc(5*5, sizeof(double));
... <load data into pr>
plhs[0] = mxCreateDoubleMatrix(5,5,mxREAL);
mxFree(mxGetPr(plhs[0]));
mxSetPr(plhs[0], pr);
```

Note that the first solution is more efficient.

Similar memory leaks can also occur when using `mxSetPi`, `mxSetData`, `mxSetImagData`, `mxSetIr`, or `mxSetJc`. You can address this issue as shown above to avoid such memory leaks.

MEX-Files Should Destroy Their Own Temporary Arrays

In general, we recommend that MEX-files destroy their own temporary arrays and clean up their own temporary memory. All `mxArrays` except those returned in the left-hand side list and those returned by `mexGetVariablePtr` may be safely destroyed. This approach is consistent with other MATLAB API applications (i.e., MAT-file applications, engine applications, and MATLAB Compiler generated applications, which do not have any automatic cleanup mechanism.)

Additional Information

The following sections describe how to find additional information and assistance in building your applications. It covers the following topics:

- “Files and Directories - UNIX Systems”
- “Files and Directories - Windows Systems”
- “Examples”
- “Technical Support”

Files and Directories - UNIX Systems

This section describes the directory organization and purpose of the files associated with the MATLAB API on UNIX systems.

The following figure illustrates the directories in which the MATLAB API files are located. In the illustration, `<matlab>` symbolizes the top-level directory where MATLAB is installed on your system.

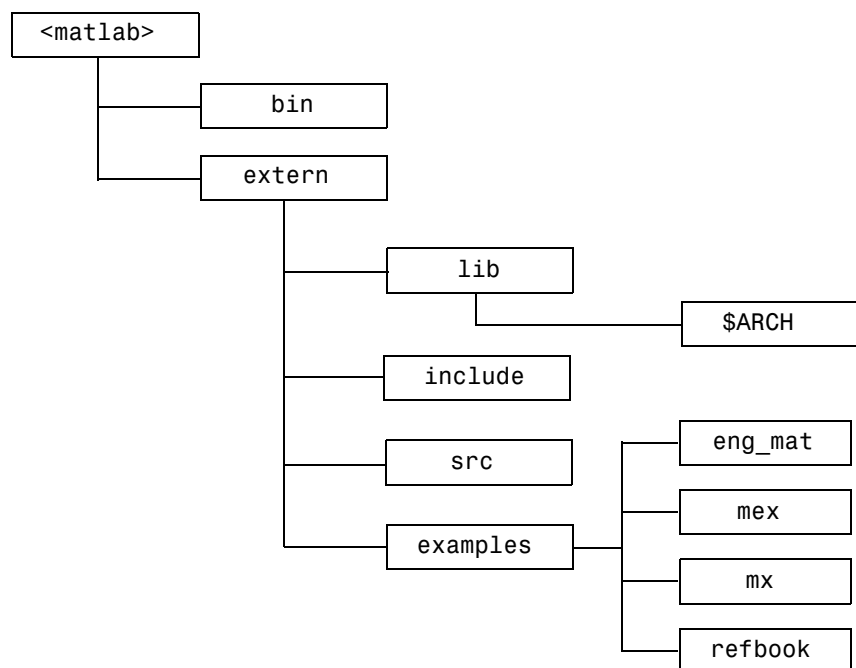

<matlab>/bin

The <matlab>/bin directory contains two files that are relevant for the MATLAB API.

mex	UNIX shell script that creates MEX-files from C or Fortran MEX-file source code.
matlab	UNIX shell script that initializes your environment and then invokes the MATLAB interpreter.

This directory also contains the preconfigured options files that the `mex` script uses with particular compilers. This table lists the options files.

Table 3-4: Preconfigured Options Files

Options File	Description
<code>engopts.sh</code>	Used with the <code>mex</code> script and the system C or Fortran compiler to compile engine applications
<code>gccopts.sh</code>	Used with the <code>mex</code> script and the GNU C (<code>gcc</code>) compiler to compile MEX-files
<code>matopts.sh</code>	Used with the <code>mex</code> script and the system C or Fortran compiler to compile MAT-file applications
<code>mexopts.sh</code>	Used with the <code>mex</code> script and the system ANSI C or Fortran compiler to compile MEX-files

<matlab>/extern/lib/\$ARCH

The `<matlab>/extern/lib/$ARCH` directory contains libraries, where `$ARCH` specifies a particular UNIX platform. On some UNIX platforms, this directory contains two versions of this library. Library filenames ending with `.a` are static libraries and filenames ending with `.so` or `.sl` are shared libraries.

<matlab>/extern/include

The `<matlab>/extern/include` directory contains the header files for developing C and C++ applications that interface with MATLAB.

The relevant header files for the MATLAB API are:

<code>engine.h</code>	Header file for MATLAB engine programs. Contains function prototypes for engine routines.
<code>mat.h</code>	Header file for programs accessing MAT-files. Contains function prototypes for <code>mat</code> routines.
<code>matrix.h</code>	Header file containing a definition of the <code>mxAarray</code> structure and function prototypes for matrix access routines.
<code>mex.h</code>	Header file for building MEX-files. Contains function prototypes for <code>mex</code> routines.

<matlab>/extern/src

The <matlab>/extern/src directory contains those C source files that are necessary to support certain MEX-file features such as argument checking and versioning.

Files and Directories - Windows Systems

This section describes the directory organization and purpose of the files associated with the MATLAB API on Microsoft Windows systems.

The following figure illustrates the directories in which the MATLAB API files are located. In the illustration, <matlab> symbolizes the top-level directory where MATLAB is installed on your system.

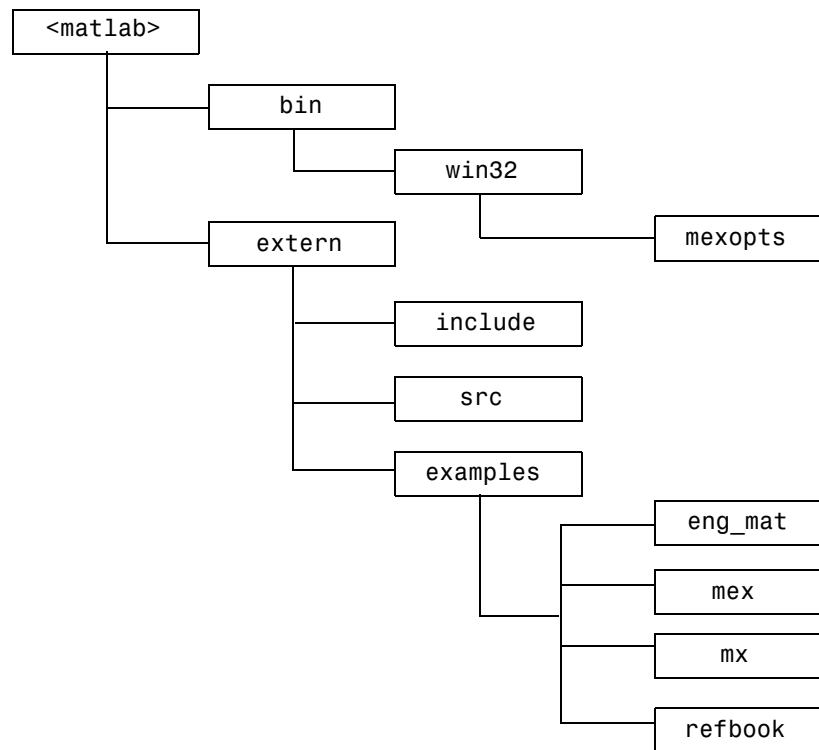

<matlab>\bin\win32

The <matlab>\bin\win32 directory contains the mex.bat batch file that builds C and Fortran files into MEX-files. Also, this directory contains mex.pl, which is a Perl script used by mex.bat.

<matlab>\bin\win32\mexopts

The <matlab>\bin\win32\mexopts directory contains the preconfigured options files that the mex script uses with particular compilers. See Table 3-2, Options Files, on page 3-15 for a complete list of the options files.

<matlab>\extern\include

The <matlab>\extern\include directory contains the header files for developing C and C++ applications that interface with MATLAB.

The relevant header files for the MATLAB API (MEX-files, engine, and MAT-files) are:

engine.h	Header file for MATLAB engine programs. Contains function prototypes for engine routines.
mat.h	Header file for programs accessing MAT-files. Contains function prototypes for mat routines.
matrix.h	Header file containing a definition of the mxArray structure and function prototypes for matrix access routines.
mex.h	Header file for building MEX-files. Contains function prototypes for mex routines.
_*.def	Files used by Borland compiler.
*.def	Files used by MSVC and Microsoft Fortran compilers.
mexversion.rc	Resource file for inserting versioning information into MEX-files.

<matlab>\extern\src

The <matlab>\extern\src directory contains files that are used for debugging MEX-files.

Examples

This book uses many examples to show how to write C and Fortran MEX-files.

Examples from the Text

The `refbook` subdirectory in the `extern/examples` directory contains the MEX-file examples (C and Fortran) that are used in this book, *External Interfaces*.

You can find the most recent versions of these examples using the anonymous FTP server locations

```
ftp://ftp.mathworks.com/pub/tech-support/docexamples/apiguide/R12/refbook
```

MEX Reference Examples

The `mex` subdirectory of `/extern/examples` directory contains MEX-file examples. It includes the examples described in the online External Interfaces/API reference pages for MEX interface functions (the functions beginning with the `mex` prefix).

You can find the most recent versions of these examples using the anonymous FTP server location

```
ftp://ftp.mathworks.com/pub/tech-support/docexamples/apiguide/R12/mex
```

MX Examples

The `mx` subdirectory of `extern/examples` contains examples for using the array access functions. Although you can use these functions in stand-alone programs, most of these are MEX-file examples. The exception is `mxSetAllocFcns.c`, since this function is available only to stand-alone programs.

You can find the most recent versions of these examples using the anonymous FTP server location

```
ftp://ftp.mathworks.com/pub/tech-support/docexamples/apiguide/R12/mx
```

Engine and MAT Examples

The `eng_mat` subdirectory in the `extern/examples` directory contains the MEX-file examples (C and Fortran) for using the MATLAB engine facility, as well as examples for reading and writing MATLAB data files (MAT-files). These examples are all stand-alone programs.

You can find the most recent versions of these examples using the anonymous FTP server locations

```
ftp://ftp.mathworks.com/pub/tech-support/docexamples/apiguide/R12/eng_mat
```

Technical Support

The MathWorks provides additional Technical Support through its web site. A few of the services provided are as follows:

- Solution Search Engine

This knowledge base on our web site includes thousands of solutions and links to Technical Notes and is updated several times each week.

```
http://www.mathworks.com/search/
```

- Technical Notes

Technical notes are written by our Technical Support staff to address commonly asked questions.

```
http://www.mathworks.com/support/tech-notes/list_all.shtml
```

Creating C Language MEX-Files

This chapter describes how to write MEX-files in the C programming language. It discusses the MEX-file itself, how these C language files interact with MATLAB, how to pass and manipulate arguments of different data types, how to debug your MEX-file programs, and several other, more advanced topics.

C MEX-Files (p. 4-2)

Examples of C MEX-Files (p. 4-6)

Advanced Topics (p. 4-36)

Debugging C Language MEX-Files
(p. 4-53)

MEX-file components and required arguments

Sample MEX-files that show how to handle all data types

Help files, linking multiple files, workspace, managing memory, using LAPACK and BLAS functions

Debugging MEX-file source code from within MATLAB

C MEX-Files

C MEX-files are built by using the `mex` script to compile your C source code with additional calls to API routines.

The Components of a C MEX-File

The source code for a MEX-file consists of two distinct parts:

- A *computational routine* that contains the code for performing the computations that you want implemented in the MEX-file. Computations can be numerical computations as well as inputting and outputting data.
- A *gateway routine* that interfaces the computational routine with MATLAB by the entry point `mexFunction` and its parameters `prhs`, `nrhs`, `plhs`, `nlhs`, where `prhs` is an array of right-hand input arguments, `nrhs` is the number of right-hand input arguments, `plhs` is an array of left-hand output arguments, and `nlhs` is the number of left-hand output arguments. The gateway calls the computational routine as a subroutine.

In the gateway routine, you can access the data in the `mxArray` structure and then manipulate this data in your C computational subroutine. For example, the expression `mxGetPr(prhs[0])` returns a pointer of type `double *` to the real data in the `mxArray` pointed to by `prhs[0]`. You can then use this pointer like any other pointer of type `double *` in C. After calling your C computational routine from the gateway, you can set a pointer of type `mxArray` to the data it returns. MATLAB is then able to recognize the output from your computational routine as the output from the MEX-file.

The following C MEX Cycle figure shows how inputs enter a MEX-file, what functions the gateway routine performs, and how outputs return to MATLAB.

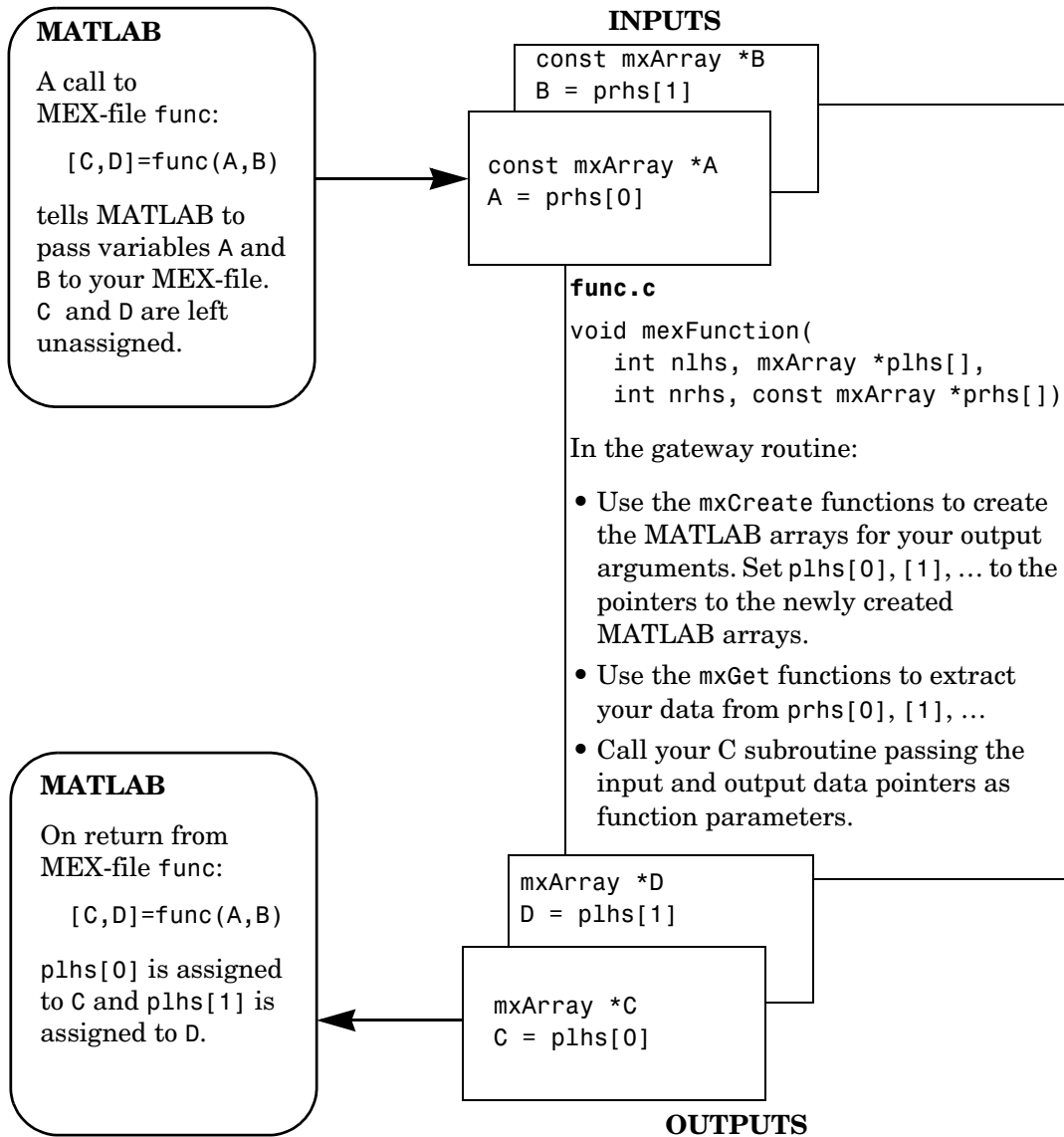

Figure 4-1: C MEX Cycle

Required Arguments to a MEX-File

The two components of the MEX-file may be separate or combined. In either case, the files must contain the `#include "mex.h"` header so that the entry point and interface routines are declared properly. The name of the gateway routine must always be `mexFunction` and must contain these parameters.

```
void mexFunction(  
    int nlhs, mxArray *plhs[],  
    int nrhs, const mxArray *prhs[])  
{  
    /* more C code ... */  
}
```

The parameters `nlhs` and `nrhs` contain the number of left- and right-hand arguments with which the MEX-file is invoked. In the syntax of the MATLAB language, functions have the general form

```
[a,b,c, ] = fun(d,e,f, )
```

where the ellipsis () denotes additional terms of the same format. The `a, b, c,` are left-hand arguments and the `d, e, f,` are right-hand arguments.

The parameters `plhs` and `prhs` are vectors that contain pointers to the left- and right-hand arguments of the MEX-file. Note that both are declared as containing type `mxArray *`, which means that the variables pointed at are MATLAB arrays. `prhs` is a length `nrhs` array of pointers to the right-hand side inputs to the MEX-file, and `plhs` is a length `nlhs` array that will contain pointers to the left-hand side outputs that your function generates.

For example, if you invoke a MEX-file from the MATLAB workspace with the command

```
x = fun(y,z);
```

the MATLAB interpreter calls `mexFunction` with the arguments.

```
nlhs = 1
```

```
nrhs = 2
```

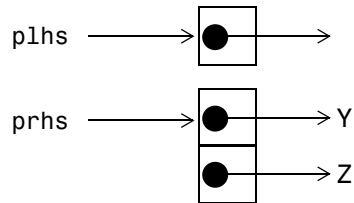

`plhs` is a 1-element C array where the single element is a null pointer. `prhs` is a 2-element C array where the first element is a pointer to an mxArray named `Y` and the second element is a pointer to an mxArray named `Z`.

The parameter `plhs` points at nothing because the output `x` is not created until the subroutine executes. It is the responsibility of the gateway routine to create an output array and to set a pointer to that array in `plhs[0]`. If `plhs[0]` is left unassigned, MATLAB prints a warning message stating that no output has been assigned.

Note It is possible to return an output value even if `nlhs = 0`. This corresponds to returning the result in the `ans` variable.

Examples of C MEX-Files

The following sections include information and examples describing how to pass and manipulate the different data types when working with MEX-files. These topics include

- “A First Example — Passing a Scalar”
- “Passing Strings”
- “Passing Two or More Inputs or Outputs”
- “Passing Structures and Cell Arrays”
- “Handling Complex Data”
- “Handling 8-,16-, and 32-Bit Data”
- “Manipulating Multidimensional Numerical Arrays”
- “Handling Sparse Arrays”
- “Calling Functions from C MEX-Files”

The MATLAB API provides a full set of routines that handle the various data types supported by MATLAB. For each data type there is a specific set of functions that you can use for data manipulation. The first example discusses the simple case of doubling a scalar. After that, the examples discuss how to pass in, manipulate, and pass back various data types, and how to handle multiple inputs and outputs. Finally, the sections discuss passing and manipulating various MATLAB data types.

Note You can find the most recent versions of the example programs at the anonymous FTP server

`ftp://ftp.mathworks.com/pub/tech-support/docexamples/apiguide/R12/refbook`

A First Example – Passing a Scalar

Let's look at a simple example of C code and its MEX-file equivalent. Here is a C computational function that takes a scalar and doubles it.

```
#include <math.h>
void timestwo(double y[], double x[])
{
    y[0] = 2.0*x[0];
    return;
}
```

Below is the same function written in the MEX-file format.

```
/*
 * =====
 * timestwo.c - example found in API guide
 *
 * Computational function that takes a scalar and doubles it.
 *
 * This is a MEX-file for MATLAB.
 * Copyright (c) 1984-2000 The MathWorks, Inc.
 * =====
 */

/* $Revision: 1.8 $ */

#include "mex.h"

void timestwo(double y[], double x[])
{
    y[0] = 2.0*x[0];
}

void mexFunction(int nlhs, mxArray *plhs[], int nrhs,
                 const mxArray *prhs[])
{
    double *x, *y;
    int mrows, ncols;
```

```
/* Check for proper number of arguments. */
if (nrhs != 1) {
    mexErrMsgTxt("One input required.");
} else if (nlhs > 1) {
    mexErrMsgTxt("Too many output arguments");
}

/* The input must be a noncomplex scalar double.*/
mrows = mxGetM(prhs[0]);
ncols = mxGetN(prhs[0]);
if (!mxIsDouble(prhs[0]) || mxIsComplex(prhs[0]) ||
    !(mrows == 1 && ncols == 1)) {
    mexErrMsgTxt("Input must be a noncomplex scalar double.");
}

/* Create matrix for the return argument. */
plhs[0] = mxCreateDoubleMatrix(mrows,ncols, mxREAL);

/* Assign pointers to each input and output. */
x = mxGetPr(prhs[0]);
y = mxGetPr(plhs[0]);

/* Call the timestwo subroutine. */
timestwo(y,x);
}
```

In C, function argument checking is done at compile time. In MATLAB, you can pass any number or type of arguments to your M-function, which is responsible for argument checking. This is also true for MEX-files. Your program must safely handle any number of input or output arguments of any supported type.

To compile and link this example source file at the MATLAB prompt, type

```
mex timestwo.c
```

This carries out the necessary steps to create the MEX-file called `timestwo` with an extension corresponding to the platform on which you're running. You can now call `timestwo` as if it were an M-function.

```
x = 2;
y = timestwo(x)
y =
    4
```

You can create and compile MEX-files in MATLAB or at your operating system's prompt. MATLAB uses `mex.m`, an M-file version of the `mex` script, and your operating system uses `mex.bat` on Windows and `mex.sh` on UNIX. In either case, typing

```
mex filename
```

at the prompt produces a compiled version of your MEX-file.

In the above example, scalars are viewed as 1-by-1 matrices. Alternatively, you can use a special API function called `mxGetScalar` that returns the values of scalars instead of pointers to copies of scalar variables. This is the alternative code (error checking has been omitted for brevity).

```
/*
 * =====
 * timestwoalt.c - example found in API guide
 *
 * Use mxGetScalar to return the values of scalars instead of
 * pointers to copies of scalar variables.
 *
 * This is a MEX-file for MATLAB.
 * Copyright (c) 1984-2000 The MathWorks, Inc.
 * =====
 */

/* $Revision: 1.5 $ */

#include "mex.h"

void timestwo_alt(double *y, double x)
{
    *y = 2.0*x;
}
```

```
void mexFunction(int nlhs, mxArray *plhs[],
                 int nrhs, const mxArray *prhs[])
{
    double *y;
    double x;

    /* Create a 1-by-1 matrix for the return argument. */
    plhs[0] = mxCreateDoubleMatrix(1, 1, mxREAL);

    /* Get the scalar value of the input x. */
    /* Note: mxGetScalar returns a value, not a pointer. */
    x = mxGetScalar(prhs[0]);

    /* Assign a pointer to the output. */
    y = mxGetPr(plhs[0]);

    /* Call the timestwo_alt subroutine. */
    timestwo_alt(y,x);
}
```

This example passes the input scalar `x` by value into the `timestwo_alt` subroutine, but passes the output scalar `y` by reference.

Passing Strings

Any MATLAB data type can be passed to and from MEX-files. For example, this C code accepts a string and returns the characters in reverse order.

```
/*
 * =====
 * revord.c
 * Example for illustrating how to copy the string data from
 * MATLAB to a C-style string and back again.
 *
 * Takes a string and returns a string in reverse order.
 *
 * This is a MEX-file for MATLAB.
 * Copyright (c) 1984-2000 The MathWorks, Inc.
 * =====
 */
```

```

/* $Revision: 1.10 $ */

#include "mex.h"

void revord(char *input_buf, int buflen, char *output_buf)
{
    int    i;

    /* Reverse the order of the input string. */
    for (i = 0; i < buflen-1; i++)
        *(output_buf+i) = *(input_buf+buflen-i-2);
}

```

In this example, the API function `mxMalloc` replaces `calloc`, the standard C function for dynamic memory allocation. `mxMalloc` allocates dynamic memory using the MATLAB memory manager and initializes it to zero. You must use `mxMalloc` in any situation where C would require the use of `calloc`. The same is true for `mxMalloc` and `mxRealloc`; use `mxMalloc` in any situation where C would require the use of `malloc` and use `mxRealloc` where C would require `realloc`.

Note MATLAB automatically frees up memory allocated with the mx allocation routines (`mxMalloc`, `mxMalloc`, `mxRealloc`) upon exiting your MEX-file. If you don't want this to happen, use the API function `mexMakeMemoryPersistent`.

Below is the gateway routine that calls the C computational routine `revord`.

```

void mexFunction(int nlhs, mxArray *plhs[],
                 int nrhs, const mxArray *prhs[])
{
    char *input_buf, *output_buf;
    int    buflen, status;

    /* Check for proper number of arguments. */
    if (nrhs != 1)
        mexErrMsgTxt("One input required.");
    else if (nlhs > 1)
        mexErrMsgTxt("Too many output arguments.");
}

```

```
/* Input must be a string. */
if (mxIsChar(prhs[0]) != 1)
    mexErrMsgTxt("Input must be a string.");

/* Input must be a row vector. */
if (mxGetM(prhs[0]) != 1)
    mexErrMsgTxt("Input must be a row vector.");

/* Get the length of the input string. */
buflen = (mxGetM(prhs[0]) * mxGetN(prhs[0])) + 1;

/* Allocate memory for input and output strings. */
input_buf = mxCalloc(buflen, sizeof(char));
output_buf = mxCalloc(buflen, sizeof(char));

/* Copy the string data from prhs[0] into a C string
 * input_buf. */
status = mxGetString(prhs[0], input_buf, buflen);
if (status != 0)
    mexWarnMsgTxt("Not enough space. String is truncated.");

/* Call the C subroutine. */
revord(input_buf, buflen, output_buf);

/* Set C-style string output_buf to MATLAB mexFunction output*/
plhs[0] = mxCreateString(output_buf);
return;
}
```

The gateway routine allocates memory for the input and output strings. Since these are C strings, they need to be one greater than the number of elements in the MATLAB string. Next the MATLAB string is copied to the input string. Both the input and output strings are passed to the computational subroutine (`revord`), which loads the output in reverse order. Note that the output buffer is a valid null-terminated C string because `mxCalloc` initializes the memory to 0. The API function `mxCreateString` then creates a MATLAB string from the C string, `output_buf`. Finally, `plhs[0]`, the left-hand side return argument to MATLAB, is set to the MATLAB array you just created.

By isolating variables of type `mxArray` from the computational subroutine, you can avoid having to make significant changes to your original C code.

In this example, typing

```
x = 'hello world';  
y = revord(x)
```

produces

```
The string to convert is 'hello world'.  
y =  
dlrow olleh
```

Passing Two or More Inputs or Outputs

The `plhs[]` and `prhs[]` parameters are vectors that contain pointers to each left-hand side (output) variable and each right-hand side (input) variable, respectively. Accordingly, `plhs[0]` contains a pointer to the first left-hand side argument, `plhs[1]` contains a pointer to the second left-hand side argument, and so on. Likewise, `prhs[0]` contains a pointer to the first right-hand side argument, `prhs[1]` points to the second, and so on.

This example, `xtimesy`, multiplies an input scalar by an input scalar or matrix and outputs a matrix. For example, using `xtimesy` with two scalars gives

```
x = 7;  
y = 7;  
z = xtimesy(x,y)  
  
z =  
    49
```

Using `xtimesy` with a scalar and a matrix gives

```
x = 9;  
y = ones(3);  
z = xtimesy(x,y)
```

```
z =
    9    9    9
    9    9    9
    9    9    9
```

This is the corresponding MEX-file C code.

```
/*
 * =====
 * xtimesy.c - example found in API guide
 *
 * Multiplies an input scalar times an input matrix and outputs a
 * matrix.
 *
 * This is a MEX-file for MATLAB.
 * Copyright (c) 1984-2000 The MathWorks, Inc.
 * =====
 */

/* $Revision: 1.10 $ */

#include "mex.h"

void xtimesy(double x, double *y, double *z, int m, int n)
{
    int i,j,count = 0;

    for (i = 0; i < n; i++) {
        for (j = 0; j < m; j++) {
            *(z+count) = x * *(y+count);
            count++;
        }
    }
}
```



```
/* The gateway routine */
void mexFunction(int nlhs, mxArray *plhs[],
                 int nrhs, const mxArray *prhs[])
{
    double *y, *z;
    double x;
    int status,mrows,ncols;

    /* Check for proper number of arguments. */
    /* NOTE: You do not need an else statement when using
       mexErrMsgTxt within an if statement. It will never
       get to the else statement if mexErrMsgTxt is executed.
       (mexErrMsgTxt breaks you out of the MEX-file.)
    */
    if (nrhs != 2)
        mexErrMsgTxt("Two inputs required.");
    if (nlhs != 1)
        mexErrMsgTxt("One output required.");

    /* Check to make sure the first input argument is a scalar. */
    if (!mxIsDouble(prhs[0]) || mxIsComplex(prhs[0]) ||
        mxGetN(prhs[0])*mxGetM(prhs[0]) != 1) {
        mexErrMsgTxt("Input x must be a scalar.");
    }

    /* Get the scalar input x. */
    x = mxGetScalar(prhs[0]);

    /* Create a pointer to the input matrix y. */
    y = mxGetPr(prhs[1]);

    /* Get the dimensions of the matrix input y. */
    mrows = mxGetM(prhs[1]);
    ncols = mxGetN(prhs[1]);

    /* Set the output pointer to the output matrix. */
    plhs[0] = mxCreateDoubleMatrix(mrows,ncols, mxREAL);

    /* Create a C pointer to a copy of the output matrix. */
    z = mxGetPr(plhs[0]);
}
```

```
    /* Call the C subroutine. */
    xtimesy(x,y,z,mrows,ncols);
}
```

As this example shows, creating MEX-file gateways that handle multiple inputs and outputs is straightforward. All you need to do is keep track of which indices of the vectors `prhs` and `plhs` correspond to the input and output arguments of your function. In the example above, the input variable `x` corresponds to `prhs[0]` and the input variable `y` to `prhs[1]`.

Note that `mxGetScalar` returns the value of `x` rather than a pointer to `x`. This is just an alternative way of handling scalars. You could treat `x` as a 1-by-1 matrix and use `mxGetPr` to return a pointer to `x`.

Passing Structures and Cell Arrays

Passing structures and cell arrays into MEX-files is just like passing any other data types, except the data itself is of type `mxArray`. In practice, this means that `mxGetField` (for structures) and `mxGetCell` (for cell arrays) return pointers of type `mxArray`. You can then treat the pointers like any other pointers of type `mxArray`, but if you want to pass the data contained in the `mxArray` to a C routine, you must use an API function such as `mxGetData` to access it.

This example takes an `m-by-n` structure matrix as input and returns a new 1-by-1 structure that contains these fields:

- String input generates an `m-by-n` cell array
- Numeric input (noncomplex, scalar values) generates an `m-by-n` vector of numbers with the same class ID as the input, for example `int`, `double`, and so on.

```
/*
 * =====
 * phonebook.c
 * Example for illustrating how to manipulate structure and cell
 * array
 *
 * Takes a (MxN) structure matrix and returns a new structure
 * (1x1) containing corresponding fields:for string input, it
 * will be (MxN) cell array; and for numeric (noncomplex, scalar)
 * input, it will be (MxN) vector of numbers with the same
```

```
* classID as input, such as int, double etc..
*
* This is a MEX-file for MATLAB.
* Copyright (c) 1984-2000 The MathWorks, Inc.
* =====
*/

/* $Revision: 1.6 $ */

#include "mex.h"
#include "string.h"

#define MAXCHARS 80 /* max length of string contained in each
                    field */

/* The gateway routine. */
void mexFunction(int nlhs, mxArray *plhs[],
                 int nrhs, const mxArray *prhs[])
{
    const char **fnames; /* pointers to field names */
    const int *dims;
    mxArray *tmp, *fout;
    char *pdata;
    int ifield, jstruct, *classIDflags;
    int NStructElems, nfields, ndim;

    /* Check proper input and output */
    if (nrhs != 1)
        mexErrMsgTxt("One input required.");
    else if (nlhs > 1)
        mexErrMsgTxt("Too many output arguments.");
    else if (!mxIsStruct(prhs[0]))
        mexErrMsgTxt("Input must be a structure.");

    /* Get input arguments */
    nfields = mxGetNumberOfFields(prhs[0]);
    NStructElems = mxGetNumberOfElements(prhs[0]);

    /* Allocate memory for storing classIDflags */
    classIDflags = mxCalloc(nfields, sizeof(int));
```

```

/* Check empty field, proper data type, and data type
   consistency; get classID for each field. */
for (ifield = 0; ifield < nfields; ifield++) {
    for (jstruct = 0; jstruct < NstructElems; jstruct++) {
        tmp = mxGetFieldByNumber(prhs[0], jstruct, ifield);
        if (tmp == NULL) {
            mexPrintf("%s%d\t%s%d\n",
                    "FIELD:", ifield+1, "STRUCT INDEX :", jstruct+1);
            mexErrMsgTxt("Above field is empty!");
        }
        if (jstruct == 0) {
            if ((!mxIsChar(tmp) && !mxIsNumeric(tmp)) ||
                mxIsSparse(tmp)) {
                mexPrintf("%s%d\t%s%d\n",
                        "FIELD:", ifield+1, "STRUCT INDEX :", jstruct+1);
                mexErrMsgTxt("Above field must have either "
                    "string or numeric non-sparse data.");
            }
            classIDflags[ifield] = mxGetClassID(tmp);
        } else {
            if (mxGetClassID(tmp) != classIDflags[ifield]) {
                mexPrintf("%s%d\t%s%d\n",
                        "FIELD:", ifield+1, "STRUCT INDEX :", jstruct+1);
                mexErrMsgTxt("Inconsistent data type in above field!");
            }
            else if (!mxIsChar(tmp) && ((mxIsComplex(tmp) ||
                mxGetNumberOfElements(tmp) != 1))) {
                mexPrintf("%s%d\t%s%d\n",
                        "FIELD:", ifield+1, "STRUCT INDEX :", jstruct+1);
                mexErrMsgTxt("Numeric data in above field "
                    "must be scalar and noncomplex!");
            }
        }
    }
}

/* Allocate memory for storing pointers */
fnames = mxCalloc(nfields, sizeof(*fnames));

```

```
/* Get field name pointers */
for (ifield = 0; ifield < nfields; ifield++) {
    fnames[ifield] = mxGetFieldNameByNumber(prhs[0],ifield);
}

/* Create a 1x1 struct matrix for output */
plhs[0] = mxCreateStructMatrix(1, 1, nfields, fnames);
mxFree(fnames);
ndim = mxGetNumberOfDimensions(prhs[0]);
dims = mxGetDimensions(prhs[0]);
for (ifield = 0; ifield < nfields; ifield++) {
    /* Create cell/numeric array */
    if (classIDflags[ifield] == mxCHAR_CLASS) {
        fout = mxCreateCellArray(ndim, dims);
    } else {
        fout = mxCreateNumericArray(ndim, dims,
            classIDflags[ifield], mxREAL);
        pdata = mxGetData(fout);
    }

    /* Copy data from input structure array */
    for (jstruct = 0; jstruct < NstructElems; jstruct++) {
        tmp = mxGetFieldByNumber(prhs[0],jstruct,ifield);
        if (mxIsChar(tmp)) {
            mxSetCell(fout, jstruct, mxDuplicateArray(tmp));
        } else {
            size_t    sizebuf;
            sizebuf = mxGetElementSize(tmp);
            memcpy(pdata, mxGetData(tmp), sizebuf);
            pdata += sizebuf;
        }
    }

    /* Set each field in output structure */
    mxSetFieldByNumber(plhs[0], 0, ifield, fout);
}
mxFree(classIDflags);
return;
}
```

To see how this program works, enter this structure.

```
friends(1).name = 'Jordan Robert';
friends(1).phone = 3386;
friends(2).name = 'Mary Smith';
friends(2).phone = 3912;
friends(3).name = 'Stacy Flora';
friends(3).phone = 3238;
friends(4).name = 'Harry Alpert';
friends(4).phone = 3077;
```

The results of this input are

```
phonebook(friends)

ans =
    name: {1x4 cell }
    phone: [3386 3912 3238 3077]
```

Handling Complex Data

Complex data from MATLAB is separated into real and imaginary parts. The MATLAB API provides two functions, `mxGetPr` and `mxGetPi`, that return pointers (of type `double *`) to the real and imaginary parts of your data.

This example takes two complex row vectors and convolves them.

```
/*
 * =====
 * convec.c
 * Example for illustrating how to pass complex data
 * from MATLAB to C and back again
 *
 * Convolves two complex input vectors.
 *
 * This is a MEX-file for MATLAB.
 * Copyright (c) 1984-2000 The MathWorks, Inc.
 * =====
 */

/* $Revision: 1.8 $ */
```

```

#include "mex.h"

/* Computational subroutine */
void convec(double *xr, double *xi, int nx, double *yr,
            double *yi, int ny, double *zr, double *zi)
{
    int i,j;

    zr[0] = 0.0;
    zi[0] = 0.0;
    /* Perform the convolution of the complex vectors. */
    for (i = 0; i < nx; i++) {
        for (j = 0; j < ny; j++) {
            *(zr+i+j) = *(zr+i+j) + *(xr+i) * *(yr+j) - *(xi+i)
                * *(yi+j);
            *(zi+i+j) = *(zi+i+j) + *(xr+i) * *(yi+j) + *(xi+i)
                * *(yr+j);
        }
    }
}

```

Below is the gateway routine that calls this complex convolution.

```

/* The gateway routine. */
void mexFunction(int nlhs, mxArray *plhs[],
                 int nrhs, const mxArray *prhs[])
{
    double *xr, *xi, *yr, *yi, *zr, *zi;
    int rows, cols, nx, ny;

    /* Check for the proper number of arguments. */
    if (nrhs != 2)
        mexErrMsgTxt("Two inputs required.");
    if (nlhs > 1)
        mexErrMsgTxt("Too many output arguments.");

    /* Check that both inputs are row vectors. */
    if (mxGetM(prhs[0]) != 1 || mxGetM(prhs[1]) != 1)
        mexErrMsgTxt("Both inputs must be row vectors.");
    rows = 1;

```

```
/* Check that both inputs are complex. */
if (!mxIsComplex(prhs[0]) || !mxIsComplex(prhs[1]))
    mexErrMsgTxt("Inputs must be complex.\n");

/* Get the length of each input vector. */
nx = mxGetN(prhs[0]);
ny = mxGetN(prhs[1]);

/* Get pointers to real and imaginary parts of the inputs. */
xr = mxGetPr(prhs[0]);
xi = mxGetPi(prhs[0]);
yr = mxGetPr(prhs[1]);
yi = mxGetPi(prhs[1]);

/* Create a new array and set the output pointer to it. */
cols = nx + ny - 1;
plhs[0] = mxCreateDoubleMatrix(rows, cols, mxCOMPLEX);
zr = mxGetPr(plhs[0]);
zi = mxGetPi(plhs[0]);

/* Call the C subroutine. */
convec(xr, xi, nx, yr, yi, ny, zr, zi);

return;
}
```

Entering these numbers at the MATLAB prompt

```
x = [3.000 - 1.000i, 4.000 + 2.000i, 7.000 - 3.000i];
y = [8.000 - 6.000i, 12.000 + 16.000i, 40.000 - 42.000i];
```

and invoking the new MEX-file

```
z = convec(x,y)
```

results in

```
z =
    1.0e+02 *
```

Columns 1 through 4

```
0.1800 - 0.2600i 0.9600 + 0.2800i 1.3200 - 1.4400i 3.7600 - 0.1200i
```

Column 5

```
1.5400 - 4.1400i
```

which agrees with the results that the built-in MATLAB function `conv.m` produces.

Handling 8-, 16-, and 32-Bit Data

You can create and manipulate signed and unsigned 8-, 16-, and 32-bit data from within your MEX-files. The MATLAB API provides a set of functions that support these data types. The API function `mxCreateNumericArray` constructs an unpopulated N-dimensional numeric array with a specified data size. Refer to the entry for `mxClassID` in the online reference pages for a discussion of how the MATLAB API represents these data types.

Once you have created an unpopulated MATLAB array of a specified data type, you can access the data using `mxGetData` and `mxGetImagData`. These two functions return pointers to the real and imaginary data. You can perform arithmetic on data of 8-, 16- or 32-bit precision in MEX-files and return the result to MATLAB, which will recognize the correct data class.

This example constructs a 2-by-2 matrix with unsigned 16-bit integers, doubles each element, and returns both matrices to MATLAB.

```
/*
 * =====
 * doubleelement.c - Example found in API Guide
 *
 * Constructs a 2-by-2 matrix with unsigned 16-bit integers,
 * doubles each element, and returns the matrix.
 *
```

```
* This is a MEX-file for MATLAB.
* Copyright (c) 1984-2000 The MathWorks, Inc.
* =====
*/

/* $Revision: 1.9 $ */

#include <string.h> /* Needed for memcpy() */
#include "mex.h"

#define NDIMS 2
#define TOTAL_ELEMENTS 4

/* The computational subroutine */
void dbl_elem(unsigned short *x)
{
    unsigned short scalar=2;
    int i,j;

    for (i=0; i<2; i++) {
        for (j=0; j<2; j++) {
            *(x+i+j) = scalar * *(x+i+j);
        }
    }
}

/* The gateway routine */
void mexFunction(int nlhs, mxArray *plhs[],
                 int nrhs, const mxArray *prhs[])
{
    const int dims[]={2,2};
    unsigned char *start_of_pr;
    unsigned short data[]={1,2,3,4};
    int bytes_to_copy;

    /* Call the computational subroutine. */
    dbl_elem(data);
}
```

```

/* Create a 2-by-2 array of unsigned 16-bit integers. */
plhs[0] = mxCreateNumericArray(NDIMS,dims,mxUINT16_CLASS,
                               mxREAL);

/* Populate the real part of the created array. */
start_of_pr = (unsigned char *)mxGetData(plhs[0]);
bytes_to_copy = TOTAL_ELEMENTS * mxGetElementSize(plhs[0]);
memcpy(start_of_pr, data, bytes_to_copy);
}

```

At the MATLAB prompt, entering

```
doubleelement
```

produces

```
ans =
     2     6
     8     4
```

The output of this function is a 2-by-2 matrix populated with unsigned 16-bit integers.

Manipulating Multidimensional Numerical Arrays

You can manipulate multidimensional numerical arrays by using `mxGetData` and `mxGetImagData` to return pointers to the real and imaginary parts of the data stored in the original multidimensional array. This example takes an N-dimensional array of doubles and returns the indices for the nonzero elements in the array.

```

/*
 * =====
 * findnz.c
 * Example for illustrating how to handle N-dimensional arrays in
 * a MEX-file. NOTE: MATLAB uses 1-based indexing, C uses 0-based
 * indexing.
 *
 * Takes an N-dimensional array of doubles and returns the indices
 * for the non-zero elements in the array. findnz works
 * differently than the FIND command in MATLAB in that it returns
 * all the indices in one output variable, where the column

```

```
* element contains the index for that dimension.
*
*
* This is a MEX-file for MATLAB.
* Copyright (c) 1984-2000 by The MathWorks, Inc.
* =====
*/

/* $Revision: 1.5 $ */

#include "mex.h"

/* If you are using a compiler that equates NaN to zero, you must
* compile this example using the flag -DNAN_EQUALS_ZERO. For
* example:
*
*     mex -DNAN_EQUALS_ZERO findnz.c
*
* This will correctly define the IsNonZero macro for your
* compiler. */

#if NAN_EQUALS_ZERO
#define IsNonZero(d) ((d) != 0.0 || mxIsNaN(d))
#else
#define IsNonZero(d) ((d) != 0.0)
#endif

void mexFunction(int nlhs, mxArray *plhs[],
                 int nrhs, const mxArray *prhs[])
{
    /* Declare variables. */
    int elements, j, number_of_dims, cplx;
    int nnz = 0, count = 0;
    double *pr, *pi, *pind;
    const int *dim_array;
```

```
/* Check for proper number of input and output arguments. */
if (nrhs != 1) {
    mexErrMsgTxt("One input argument required.");
}
if (nlhs > 1) {
    mexErrMsgTxt("Too many output arguments.");
}

/* Check data type of input argument. */
if (!(mxIsDouble(prhs[0]))) {
    mexErrMsgTxt("Input array must be of type double.");
}

/* Get the number of elements in the input argument. */
elements = mxGetNumberOfElements(prhs[0]);

/* Get the data. */
pr = (double *)mxGetPr(prhs[0]);
pi = (double *)mxGetPi(prhs[0]);
cplx = ((pi == NULL) ? 0 : 1);

/* Count the number of non-zero elements to be able to allocate
the correct size for output variable. */
for (j = 0; j < elements; j++) {
    if (IsNonZero(pr[j]) || (cplx && IsNonZero(pi[j]))) {
        nnz++;
    }
}

/* Get the number of dimensions in the input argument.
Allocate the space for the return argument */
number_of_dims = mxGetNumberOfDimensions(prhs[0]);
plhs[0] = mxCreateDoubleMatrix(nnz, number_of_dims, mxREAL);
pind = mxGetPr(plhs[0]);

/* Get the number of dimensions in the input argument. */
dim_array = mxGetDimensions(prhs[0]);
```

```
/* Fill in the indices to return to MATLAB. This loops through
 * the elements and checks for non-zero values. If it finds a
 * non-zero value, it then calculates the corresponding MATLAB
 * indices and assigns them into the output array. The 1 is added
 * to the calculated index because MATLAB is 1-based and C is
 * 0-based. */
for (j = 0; j < elements; j++) {
    if (IsNonZero(pr[j]) || (cplx && IsNonZero(pi[j]))) {
        int temp = j;
        int k;
        for (k = 0; k < number_of_dims; k++) {
            pind[nnz*k+count] = ((temp % (dim_array[k])) + 1);
            temp /= dim_array[k];
        }
        count++;
    }
}
}
```

Entering a sample matrix at the MATLAB prompt gives

```
matrix = [ 3 0 9 0; 0 8 2 4; 0 9 2 4; 3 0 9 3; 9 9 2 0]
matrix =
     3     0     9     0
     0     8     2     4
     0     9     2     4
     3     0     9     3
     9     9     2     0
```

This example determines the position of all nonzero elements in the matrix. Running the MEX-file on this matrix produces

```
nz = findnz(matrix)
nz =
     1     1
     4     1
     5     1
     2     2
     3     2
     5     2
     1     3
```

```

2    3
3    3
4    3
5    3
2    4
3    4
4    4

```

Handling Sparse Arrays

The MATLAB API provides a set of functions that allow you to create and manipulate sparse arrays from within your MEX-files. These API routines access and manipulate `ir` and `jc`, two of the parameters associated with sparse arrays. For more information on how MATLAB stores sparse arrays, refer to the section, “The MATLAB Array” on page 3-4.

This example illustrates how to populate a sparse matrix.

```

/*
 * =====
 * fulltosparse.c
 * This example demonstrates how to populate a sparse
 * matrix. For the purpose of this example, you must pass in a
 * non-sparse 2-dimensional argument of type double.
 *
 * Comment: You might want to modify this MEX-file so that you can
 * use it to read large sparse data sets into MATLAB.
 *
 * This is a MEX-file for MATLAB.
 * Copyright (c) 1984-2000 The MathWorks, Inc.
 * =====
 */

/* $Revision: 1.5 $ */

#include <math.h> /* Needed for the ceil() prototype. */
#include "mex.h"

/* If you are using a compiler that equates NaN to be zero, you
 * must compile this example using the flag -DNAN_EQUALS_ZERO.
 * For example:

```

```
*
*      mex -DNAN_EQUALS_ZERO fulltosparse.c
*
* This will correctly define the IsNonZero macro for your C
* compiler.
*/

#if defined(NAN_EQUALS_ZERO)
#define IsNonZero(d) ((d) != 0.0 || mxIsNaN(d))
#else
#define IsNonZero(d) ((d) != 0.0)
#endif

void mexFunction(
    int nlhs,          mxArray *plhs[],
    int nrhs, const mxArray *prhs[]
)
{
    /* Declare variables. */
    int j,k,m,n,nzmax,*irs,*jcs,cmplx,isfull;
    double *pr,*pi,*si,*sr;
    double percent_sparse;

    /* Check for proper number of input and output arguments. */
    if (nrhs != 1) {
        mexErrMsgTxt("One input argument required.");
    }
    if (nlhs > 1) {
        mexErrMsgTxt("Too many output arguments.");
    }

    /* Check data type of input argument. */
    if (!(mxIsDouble(prhs[0]))) {
        mexErrMsgTxt("Input argument must be of type double.");
    }

    if (mxGetNumberOfDimensions(prhs[0]) != 2) {
        mexErrMsgTxt("Input argument must be two dimensional\n");
    }
}
```



```

/* Get the size and pointers to input data. */
m = mxGetM(prhs[0]);
n = mxGetN(prhs[0]);
pr = mxGetPr(prhs[0]);
pi = mxGetPi(prhs[0]);
cmlpx = (pi == NULL ? 0 : 1);

/* Allocate space for sparse matrix.
 * NOTE: Assume at most 20% of the data is sparse. Use ceil
 * to cause it to round up.
 */

percent_sparse = 0.2;
nzmax = (int)ceil((double)m*(double)n*percent_sparse);

plhs[0] = mxCreateSparse(m,n,nzmax,cmlpx);
sr = mxGetPr(plhs[0]);
si = mxGetPi(plhs[0]);
irs = mxGetIr(plhs[0]);
jcs = mxGetJc(plhs[0]);

/* Copy nonzeros. */
k = 0;
isfull = 0;
for (j = 0; (j < n); j++) {
    int i;
    jcs[j] = k;
    for (i = 0; (i < m); i++) {
        if (IsNonZero(pr[i]) || (cmlpx && IsNonZero(pi[i]))) {

            /* Check to see if non-zero element will fit in
             * allocated output array. If not, increase
             * percent_sparse by 10%, recalculate nzmax, and augment
             * the sparse array.
             */
            if (k >= nzmax) {
                int oldnzmax = nzmax;
                percent_sparse += 0.1;
                nzmax = (int)ceil((double)m*(double)n*percent_sparse);
            }
        }
    }
}

```

```
/* Make sure nzmax increases atleast by 1. */
if (oldnzmax == nzmax)
    nzmax++;

mxSetNzmax(plhs[0], nzmax);
mxSetPr(plhs[0], mxRealloc(sr, nzmax*sizeof(double)));
if (si != NULL)
mxSetPi(plhs[0], mxRealloc(si, nzmax*sizeof(double)));
mxSetIr(plhs[0], mxRealloc(irs, nzmax*sizeof(int)));

sr = mxGetPr(plhs[0]);
si = mxGetPi(plhs[0]);
irs = mxGetIr(plhs[0]);
}
sr[k] = pr[i];
if (cplx) {
    si[k] = pi[i];
}
irs[k] = i;
k++;
}
}
pr += m;
pi += m;
}
jcs[n] = k;
}
```

At the MATLAB prompt, entering

```
full = eye(5)
full =
    1    0    0    0    0
    0    1    0    0    0
    0    0    1    0    0
    0    0    0    1    0
    0    0    0    0    1
```

creates a full, 5-by-5 identity matrix. Using `fulltosparse` on the full matrix produces the corresponding sparse matrix.

```
spar = fulltosparse(full)
spar =
    (1,1)      1
    (2,2)      1
    (3,3)      1
    (4,4)      1
    (5,5)      1
```

Calling Functions from C MEX-Files

It is possible to call MATLAB functions, operators, M-files, and other MEX-files from within your C source code by using the API function `mexCallMATLAB`. This example creates an `mxArray`, passes various pointers to a subfunction to acquire data, and calls `mexCallMATLAB` to calculate the sine function and plot the results.

```
/*
 * =====
 * sincall.c
 *
 * Example for illustrating how to use mexCallMATLAB
 *
 * Creates an mxArray and passes its associated pointers (in
 * this demo, only pointer to its real part, pointer to number of
 * rows, pointer to number of columns) to subfunction fill() to
 * get data filled up, then calls mexCallMATLAB to calculate sin
 * function and plot the result.
 *
 * This is a MEX-file for MATLAB.
 * Copyright (c) 1984-2000 The MathWorks, Inc.
 * =====
 */

/* $Revision: 1.4 $ */

#include "mex.h"
#define MAX 1000
```

```
/* Subroutine for filling up data */
void fill(double *pr, int *pm, int *pn, int max)
{
    int i;

    /* You can fill up to max elements, so (*pr) <= max. */
    *pm = max/2;
    *pn = 1;
    for (i = 0; i < (*pm); i++)
        pr[i] = i * (4*3.14159/max);
}

/* The gateway routine */
void mexFunction(int nlhs, mxArray *plhs[],
                 int nrhs, const mxArray *prhs[])
{
    int m, n, max = MAX;
    mxArray *rhs[1], *lhs[1];

    rhs[0] = mxCreateDoubleMatrix(max, 1, mxREAL);

    /* Pass the pointers and let fill() fill up data. */
    fill(mxGetPr(rhs[0]), &m, &n, MAX);
    mxSetM(rhs[0], m);
    mxSetN(rhs[0], n);

    /* Get the sin wave and plot it. */
    mexCallMATLAB(1, lhs, 1, rhs, "sin");
    mexCallMATLAB(0, NULL, 1, lhs, "plot");

    /* Clean up allocated memory. */
    mxDestroyArray(rhs[0]);
    mxDestroyArray(lhs[0]);

    return;
}
```

Running this example

```
sincall
```

displays the results

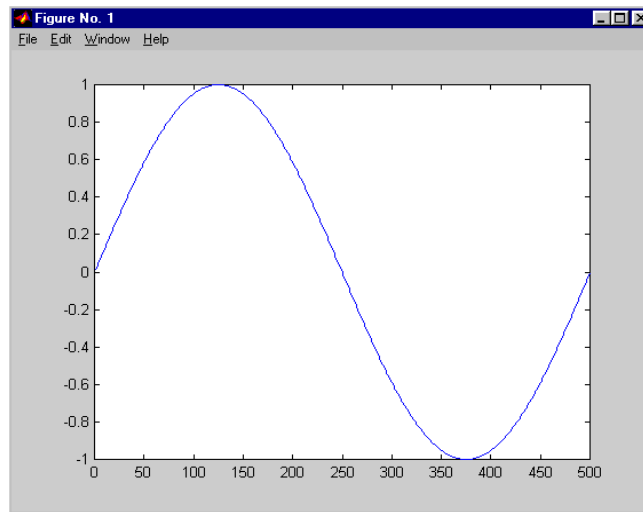

Note It is possible to generate an object of type `mxUNKNOWN_CLASS` using `mexCallMATLAB`. See the example below.

The following example creates an M-file that returns two variables but only assigns one of them a value.

```
function [a,b] = foo[c]
a = 2*c;
```

MATLAB displays the following warning message.

```
Warning: One or more output arguments not assigned during call to
'foo'.
```

If you then call `foo` using `mexCallMATLAB`, the unassigned output variable will now be of type `mxUNKNOWN_CLASS`.

Advanced Topics

These sections cover advanced features of MEX-files that you can use when your applications require sophisticated MEX-files:

- “Help Files”
- “Linking Multiple Files”
- “Workspace for MEX-File Functions” on page 4-37
- “Memory Management” on page 4-37
- “Large File I/O” on page 4-40
- “Using LAPACK and BLAS Functions” on page 4-45

Help Files

Because the MATLAB interpreter chooses the MEX-file when both an M-file and a MEX-file with the same name are encountered in the same directory, it is possible to use M-files for documenting the behavior of your MEX-files. The MATLAB help command will automatically find and display the appropriate M-file when help is requested and the interpreter will find and execute the corresponding MEX-file when the function is invoked.

Linking Multiple Files

It is possible to combine several object files and to use object file libraries when building MEX-files. To do so, simply list the additional files with their full extension, separated by spaces. For example, on the PC

```
mex circle.c square.obj rectangle.c shapes.lib
```

is a legal command that operates on the .c, .obj, and .lib files to create a MEX-file called `circle.dll`, where `dll` is the extension corresponding to the MEX-file type on the PC. The name of the resulting MEX-file is taken from the first file in the list.

You may find it useful to use a software development tool like MAKE to manage MEX-file projects involving multiple source files. Simply create a MAKEFILE that contains a rule for producing object files from each of your source files and then invoke `mex` to combine your object files into a MEX-file. This way you can ensure that your source files are recompiled only when necessary.

Note On UNIX, you must use the `-cxx` switch to the `mex` script if you are linking C++ objects.

Workspace for MEX-File Functions

Unlike M-file functions, MEX-file functions do not have their own variable workspace. MEX-file functions operate in the caller's workspace.

`mexEvalString` evaluates the string in the caller's workspace. In addition, you can use the `mexGetVariable` and `mexPutVariable` routines to get and put variables into the caller's workspace.

Memory Management

Memory management within MEX-files is not unlike memory management for regular C or Fortran applications. However, there are special considerations because the MEX-file must exist within the context of a larger application, i.e., MATLAB itself.

Automatic Cleanup of Temporary Arrays

When a MEX-file returns to MATLAB, it gives to MATLAB the results of its computations in the form of the left-hand side arguments – the `mxArrays` contained within the `plhs[]` list. Any `mxArrays` created by the MEX-file that are not in this list are automatically destroyed. In addition, any memory allocated with `mxMalloc`, `mxCalloc`, or `mxRealloc` during the MEX-file's execution is automatically freed.

In general, we recommend that MEX-files destroy their own temporary arrays and free their own dynamically allocated memory. It is more efficient for the MEX-file to perform this cleanup than to rely on the automatic mechanism. However, there are several circumstances in which the MEX-file will not reach its normal return statement. The normal return will not be reached if:

- A call to `mexErrMsgTxt` occurs.
- A call to `mexCallMATLAB` occurs and the function being called creates an error. (A MEX-file can trap such errors by using `mexSetTrapFlag`, but not all MEX-files would necessarily need to trap errors.)
- The user interrupts the MEX-file's execution using **Ctrl-C**.

- The MEX-file runs out of memory. When this happens, the MATLAB out-of-memory handler will immediately terminate the MEX-file.

A careful MEX-file programmer can ensure safe cleanup of all temporary arrays and memory before returning in the first two cases, but not in the last two cases. In the last two cases, the automatic cleanup mechanism is necessary to prevent memory leaks.

Persistent Arrays

You can exempt an array, or a piece of memory, from the MATLAB automatic cleanup by calling `mexMakeArrayPersistent` or `mexMakeMemoryPersistent`. However, if a MEX-file creates such persistent objects, there is a danger that a memory leak could occur if the MEX-file is cleared before the persistent object is properly destroyed. In order to prevent this from happening, a MEX-file that creates persistent objects should register a function, using `mexAtExit`, which will dispose of the objects. (You can use a `mexAtExit` function to dispose of other resources as well; for example, you can use `mexAtExit` to close an open file.)

For example, here is a simple MEX-file that creates a persistent array and properly disposes of it.

```
#include "mex.h"

static int initialized = 0;
static mxArray *persistent_array_ptr = NULL;

void cleanup(void) {
    mexPrintf("MEX-file is terminating, destroying array\n");
    mxDestroyArray(persistent_array_ptr);
}

void mexFunction(int nlhs,
                 mxArray *plhs[],
                 int nrhs,
                 const mxArray *prhs[])
{
    if (!initialized) {
        mexPrintf("MEX-file initializing, creating array\n");

        /* Create persistent array and register its cleanup. */
        persistent_array_ptr = mxCreateDoubleMatrix(1, 1, mxREAL);
    }
}
```



```

mexMakeArrayPersistent(persistent_array_ptr);
mexAtExit(cleanup);
initialized = 1;

/* Set the data of the array to some interesting value. */
*mexGetPr(persistent_array_ptr) = 1.0;
} else {
mexPrintf("MEX-file executing; value of first array
          element is %g\n", *mexGetPr(persistent_array_ptr));
}
}
}

```

Hybrid Arrays

Functions such as `mxSetPr`, `mxSetData`, and `mxSetCell` allow the direct placement of memory pieces into an `mxArray`. `mxDestroyArray` will destroy these pieces along with the entire array. Because of this, it is possible to create an array that cannot be destroyed, i.e., an array on which it is not safe to call `mxDestroyArray`. Such an array is called a *hybrid* array, because it contains both destroyable and nondestroyable components.

For example, it is not legal to call `mxFree` (or the ANSI `free()` function, for that matter) on automatic variables. Therefore, in the following code fragment, `pArray` is a hybrid array.

```

mxArray *pArray = mxCreateDoubleMatrix(0, 0, mxREAL);
double data[10];

mxSetPr(pArray, data);
mxSetM(pArray, 1);
mxSetN(pArray, 10);

```

Another example of a hybrid array is a cell array or structure, one of whose children is a read-only array (an array with the `const` qualifier, such as one of the inputs to the MEX-file). The array cannot be destroyed because the input to the MEX-file would also be destroyed.

Because hybrid arrays cannot be destroyed, they cannot be cleaned up by the automatic mechanism outlined in “Automatic Cleanup of Temporary Arrays” on page 4-37. As described in that section, the automatic cleanup mechanism is the only way to destroy temporary arrays in case of a user interrupt. Therefore, *temporary hybrid arrays are illegal* and can cause your MEX-file to

crash. Although persistent hybrid arrays are viable, it is best to avoid using them whenever possible.

Large File I/O

MATLAB supports the use of 64-bit file I/O operations in your MEX-file programs. This enables you to read and write data to files that are up to and greater than 2 GB ($2^{31}-1$ bytes) in size. Note that some operating systems or compilers might not support files larger than 2 GB.

This section covers the following topics on large file I/O:

- “Prerequisites to Using 64-Bit I/O”
- “Specifying Constant Literal Values” on page 4-42
- “Opening a File” on page 4-42
- “Printing Formatted Messages” on page 4-43
- “Replacing fseek and ftell with 64-Bit Functions” on page 4-43
- “Determining the Size of an Open File” on page 4-44
- “Determining the Size of a Closed File” on page 4-45

Prerequisites to Using 64-Bit I/O

This section describes the components you will need to use 64-bit file I/O in your MEX-file programs:

- “Header File” on page 4-40
- “Type Declarations” on page 4-41
- “Functions” on page 4-41

Header File. Header file `io64.h` defines many of the types and functions required for 64-bit file I/O. The statement to include this file must be the *first* `#include` statement in your source file, and must also precede any system header include statements:

```
#include "io64.h"
#include "mex.h"
.
.
.
```

Type Declarations. Use the following types to declare variables used in 64-bit file I/O.

MEX Type	Description	POSIX
fpos_T	Declares a 64-bit int type for setFilePos() and getFilePos(). Defined in io64.h.	fpos_t
int64_T, uint64_T	Declares 64-bit signed and unsigned integer types. Defined in tmwtypes.h.	long long
structStat	Declares a structure to hold the size of a file. Defined in io64.h.	struct stat
FMT64	Used in mexPrintf to specify length within a format specifier such as %d. See example in the section “Printing Formatted Messages” on page 4-43. FMT64 is defined in tmwtypes.h.	%lld
LL, LLU	Suffixes for literal int constant 64-bit values (C Standard ISO/IEC 9899:1999(E) Section 6.4.4.1). Used only on UNIX.	LL, LLU

Functions. Here are the functions you will need for 64-bit file I/O. All are defined in the header file io64.h.

Function	Description	POSIX
fileno()	Gets a file descriptor from a file pointer	fileno()
fopen()	Opens the file and obtains the file pointer	fopen()
getFileFstat()	Gets the file size of a given file pointer	fstat()
getFilePos()	Gets the file position for the next I/O	fgetpos()
getFileStat()	Gets the file size of a given filename	stat()
setFilePos()	Sets the file position for the next I/O	fsetpos()

Specifying Constant Literal Values

To assign signed and unsigned 64-bit integer literal values, use type definitions `int64_T` and `uint64_T`.

On UNIX, to assign a literal value to an integer variable where the value to be assigned is greater than $2^{31}-1$ signed, you must suffix the value with `LL`. If the value is greater than $2^{32}-1$ unsigned, then use `LLU` as the suffix. These suffixes apply only to UNIX systems and are considered invalid on Windows systems.

Note The `LL` and `LLU` suffixes are not required for hardcoded (literal) values less than 2G ($2^{31}-1$), even if they are assigned to a 64-bit `int` type.

The following example declares a 64-bit integer variable initialized with a large literal `int` value, and two 64-bit integer variables:

```
void mexFunction(int nlhs, mxArray *plhs[], int nrhs,
                 const mxArray *prhs[])
{
    #if defined(_MSC_VER) || defined(__BORLANDC__)    /* Windows */
        int64_T large_offset_example = 9000222000;
    #else                                           /* UNIX */
        int64_T large_offset_example = 9000222000LL;
    #endif

    int64_T offset = 0;
    int64_T position = 0;
```

Opening a File

To open a file for reading or writing, use the C `fopen` function as you normally would. As long as you have included `io64.h` at the start of your program, `fopen` will work correctly for large files. No changes at all are required for `fread`, `fwrite`, `fprintf`, `fscanf`, and `fclose`.

To open an existing file for read and update in binary mode,

```

fp = fopen(filename, "r+b");
if (NULL == fp)
{
    /* File does not exist. Create new file for writing
    * in binary mode.
    */
    fp = fopen(filename, "wb");
    if (NULL == fp)
    {
        sprintf(str, "Failed to open/create test file '%s'",
            filename);
        mexErrMsgTxt(str);
        return;
    }
    else
    {
        mexPrintf("New test file '%s' created\n",filename);
    }
}
else mexPrintf("Existing test file '%s' opened\n",filename);

```

Printing Formatted Messages

You cannot print 64-bit integers using the %d conversion specifier. Instead, use FMT64 to specify the appropriate format for your platform. FMT64 is defined in the header file `tmwtypes.h`. The following example shows how to print a message showing the size of a large file:

```

int64_T large_offset_example = 9000222000LL;

mexPrintf("Example large file size: %" FMT64 "d bytes.\n",
    large_offset_example);

```

Replacing `fseek` and `ftell` with 64-Bit Functions

The ANSI C `fseek` and `ftell` functions are not 64-bit file I/O capable on most platforms. The functions `setFilePos` and `getFilePos`, however, are defined as the corresponding POSIX `fsetpos` and `fgetpos`, (or `fsetpos64` and `fgetpos64`), as required by your platform/OS. These functions are 64-bit file I/O capable on all platforms.

The following example shows how to use `setFilePos` instead of `fseek`, and `getFilePos` instead of `ftell`. It uses `getFileFstat` to find the size of the file, and then uses `setFilePos` to seek to the end of the file to prepare for adding data at the end of the file.

Note Although the `offset` parameter to `setFilePos` and `getFilePos` is really a pointer to a signed 64-bit integer, `int64_T`, it must be cast to an `fpos_T*`. The `fpos_T` type is defined in `io64.h` as the appropriate `fpos64_t` or `fpos_t`, as required by your platform/OS.

```
getFileFstat(fileno(fp), &statbuf);
fileSize = statbuf.st_size;
offset = fileSize;

setFilePos(fp, (fpos_T*) &offset);
getFilePos(fp, (fpos_T*) &position );
```

Unlike `fseek`, `setFilePos` supports only absolute seeking relative to the beginning of the file. If you want to do a relative seek, first call `getFileFstat` to obtain the file size, then convert the relative offset to an absolute offset that you can pass to `setFilePos`.

Determining the Size of an Open File

Getting the size of an open file involves two steps:

- 1 Refresh the record of the file size stored in memory using `getFilePos` and `setFilePos`.
- 2 Retrieve the size of the file using `getFileFstat`.

Refreshing the File Size Record. Before attempting to retrieve the size of an open file, you should first refresh the record of the file size residing in memory. If you skip this step on a file that is opened for writing, the file size returned might be incorrect or 0.

To refresh the file size record, seek to any offset in the file using `setFilePos`. If you do not want to change the position of the file pointer, you can seek to the current position in the file. This example obtains the current offset from the

start of the file and then seeks to the current position to update the file size without moving the file pointer:

```
getFilePos( fp, (fpos_T*) &position);
setFilePos( fp, (fpos_T*) &position);
```

Getting the File Size. The `getFileFstat` function takes a file descriptor input argument (that you can obtain from the file pointer of the open file using `fileno`), and returns the size of that file in bytes in the `st_size` field of a `structStat` structure:

```
structStat statbuf;
int64_T fileSize = 0;

if (0 == getFileFstat(fileno(fp), &statbuf))
{
    fileSize = statbuf.st_size;
    mexPrintf("File size is %" FMT64 "d bytes\n", fileSize);
}
```

Determining the Size of a Closed File

The `getFileStat` function takes the filename of a closed file as an input argument, and returns the size of the file in bytes in the `st_size` field of a `structStat` structure:

```
structStat statbuf;
int64_T fileSize = 0;

if (0 == getFileStat(filename, &statbuf))
{
    fileSize = statbuf.st_size;
    mexPrintf("File size is %" FMT64 "d bytes\n", fileSize);
}
```

Using LAPACK and BLAS Functions

LAPACK is a large, multiauthor Fortran subroutine library that MATLAB uses for numerical linear algebra. BLAS, which stands for Basic Linear Algebra Subroutines, is used by MATLAB to speed up matrix multiplication and the LAPACK routines themselves. The functions provided by LAPACK and BLAS can also be called directly from within your C MEX-files.

This section explains how to write and build MEX-files that call LAPACK and BLAS functions. It provides information on

- “Specifying the Function Name”
- “Calling LAPACK and BLAS Functions from C”
- “Handling Complex Numbers” on page 4-47
- “Preserving Input Values from Modification” on page 4-49
- “Building the C MEX-File” on page 4-49
- “Example – Symmetric Indefinite Factorization Using LAPACK” on page 4-51
- “Calling LAPACK and BLAS Functions from Fortran” on page 4-51
- “Building the Fortran MEX-File” on page 4-52

Specifying the Function Name

When calling an LAPACK or BLAS function, some platforms require an underscore character following the function name in the call statement.

On the PC and HP platforms, use the function name alone, with no trailing underscore. For example, to call the LAPACK `dgemm` function, use

```
dgemm (arg1, arg2, ..., argn);
```

On the LINUX, Solaris, and Macintosh platforms, add the underscore after the function name. For example, to call `dgemm` on any of these platforms, use

```
dgemm_ (arg1, arg2, ..., argn);
```

Calling LAPACK and BLAS Functions from C

Since the LAPACK and BLAS functions are written in Fortran, arguments passed to and from these functions must be passed by reference. The following example calls `dgemm`, passing all arguments by reference. An ampersand (&) precedes each argument unless that argument is already a reference.

```
#include "mex.h"

void mexFunction(int nlhs, mxArray *plhs[], int nrhs, mxArray
*prhs[])
{
    double *A, *B, *C, one = 1.0, zero = 0.0;
    int m,n,p;
```



```

char *chn = "N";

A = mxGetPr(prhs[0]);
B = mxGetPr(prhs[1]);
m = mxGetM(prhs[0]);
p = mxGetN(prhs[0]);
n = mxGetN(prhs[1]);

if (p != mxGetM(prhs[1])) {
    mexErrMsgTxt("Inner dimensions of matrix multiply do not
        match");
}

plhs[0] = mxCreateDoubleMatrix(m, n, mxREAL);
C = mxGetPr(plhs[0]);

/* Pass all arguments to Fortran by reference */
dgemm (chn, chn, &m, &n, &p, &one, A, &m, B, &p, &zero, C, &m);
}

```

Handling Complex Numbers

MATLAB stores complex numbers differently than Fortran. MATLAB stores the real and imaginary parts of a complex number in separate, equal length vectors, `pr` and `pi`. Fortran stores the same number in one location with the real and imaginary parts interleaved.

As a result, complex variables exchanged between MATLAB and the Fortran functions in LAPACK and BLAS are incompatible. MATLAB provides conversion routines that change the storage format of complex numbers to address this incompatibility.

Input Arguments. For all complex variables passed as input arguments to a Fortran function, you need to convert the storage of the MATLAB variable to be compatible with the Fortran function. Use the `mat2fort` function for this. See the example that follows.

Output Arguments. For all complex variables passed as output arguments to a Fortran function, you need to do the following:

- 1 When allocating storage for the complex variable, allocate a real variable with twice as much space as you would for a MATLAB variable of the same size. You need to do this because the returned variable uses the Fortran format, which takes twice the space. See the allocation of `zout` in the example that follows.
- 2 Once the variable is returned to MATLAB, convert its storage so that it is compatible with MATLAB. Use the `fort2mat` function for this.

Example – Passing Complex Variables. The example below shows how to call an LAPACK function from MATLAB, passing complex `prhs[0]` as input and receiving complex `plhs[0]` as output. Temporary variables `zin` and `zout` are used to hold `prhs[0]` and `plhs[0]` in Fortran format.

```
#include "mex.h"
#include "fort.h"      /* defines mat2fort and fort2mat */

void mexFunction(int nlhs, mxArray *plhs[], int nrhs, mxArray
*prhs[])
{
    int lda, n;
    double *zin, *zout;
    lda = mxGetM(prhs[0]);
    n = mxGetN(prhs[0]);

    /* Convert input to Fortran format */
    zin = mat2fort(prhs[0], lda, n);

    /* Allocate a real, complex, lda-by-n variable to store output */
    zout = mxCalloc(2*lda*n, sizeof(double));

    /* Call complex LAPACK function */
    zlapack_function(zin, &lda, &n, zout);

    /* Convert output to MATLAB format */
    plhs[0] = fort2mat(zout, lda, lda, n);
}
```

```

    /* Free intermediate Fortran format arrays */
    mxFree(zin);
    mxFree(zout);
}

```

Preserving Input Values from Modification

Many LAPACK and BLAS functions modify the values of arguments passed in to them. It is advisable to make a copy of arguments that can be modified prior to passing them to the function. For complex inputs, this point is moot since the `mat2fort` version of the input is a new piece of memory, but for real data this is not the case.

The following example calls an LAPACK function that modifies the first input argument. The code in this example makes a copy of `prhs[0]`, and then passes the copy to the LAPACK function to preserve the contents of `prhs[0]`.

```

    /* lapack_function modifies A so make a copy of the input */
    m = mxGetM(prhs[0]);
    n = mxGetN(prhs[0]);
    A = mxCalloc(m*n, sizeof(double));

    /* Copy mxGetPr(prhs[0]) into A */
    temp = mxGetPr(prhs[0]);
    for (k = 0; k < m*n; k++) {
        A[k] = temp[k];
    }

    /* lapack_function does not modify B so it is OK to use the input
    directly */
    B = mxGetPr(prhs[1]);
    lapack_function(A, B);          /* modifies A but not B */

    /* Free A when you are done with it */
    mxFree(A);

```

Building the C MEX-File

The examples in this section show how to compile and link a C MEX file, `myCmexFile.c`, on the platforms supported by MATLAB. In each example, the term `<matlab>` stands for the MATLAB root directory.

Building on the PC. If you build your C MEX-file on a PC platform, you need to explicitly specify a library file to link with.

On the PC, use this command if you are using the Lcc compiler that ships with MATLAB:

```
mex myCmexFile.c <matlab>/extern/lib/win32/lcc/libmwlpack.lib
```

Or, use this command if you are using Microsoft Visual C++ as your C compiler:

```
mex myCmexFile.c  
<matlab>/extern/lib/win32/microsoft/msvc60/libmwlpack.lib
```

Building on Other Platforms. On all other platforms, you can build your MEX-file as you would any other C MEX-file. For example,

```
mex myCmexFile.c
```

MEX-Files That Perform Complex Number Conversion. MATLAB supplies the files `fort.c` and `fort.h`, which provide routines for conversion between MATLAB and FORTRAN complex data structures. These files define the `mat2fort` and `fort2mat` routines mentioned previously under “Handling Complex Numbers” on page 4-47.

If your program uses these routines, then you need to:

- 1 Include the `fort.h` file in your program, using `#include "fort.h"`. See the example above.
- 2 Build the `fort.c` file with your program. Specify the pathname, `<matlab>/extern/examples/refbook` for both `fort.c` and `fort.h` in the build command, (where `<matlab>` stands for the MATLAB root directory).

On the PC, use either one of the following.

```
mex myCmexFile.c <matlab>/extern/examples/refbook/fort.c  
-I<matlab>/extern/examples/refbook  
<matlab>/extern/lib/win32/microsoft/msvc60/libmwlpack.lib
```

```
mex myCmexFile.c <matlab>/extern/examples/refbook/fort.c  
-I<matlab>/extern/examples/refbook  
<matlab>/extern/lib/win32/lcc/libmwlpack.lib
```

For all other platforms, use

```
mex myCmexFile.c <matlab>/extern/examples/refbook/fort.c  
-I<matlab>/extern/examples/refbook
```

Example – Symmetric Indefinite Factorization Using LAPACK

You will find an example C MEX-file that calls two LAPACK functions in the directory <matlab>/extern/examples/refbook, where <matlab> stands for the MATLAB root directory. There are two versions of this file:

- `utdu_slv.c` – calls functions `zhesvx` and `dsysvx`, and thus is compatible with the PC and HP platforms.
- `utdu_slv_.c` – calls functions `zhesvx_` and `dsysvx_`, and thus is compatible with the LINUX and Solaris platforms.

Calling LAPACK and BLAS Functions from Fortran

You can make calls to the LAPACK and BLAS functions used by MATLAB from your Fortran MEX files. The following is an example program that takes two matrices and multiplies them by calling the LAPACK routine, `dgemm`:

```
subroutine mexFunction(nlhs, plhs, nrhs, prhs)  
integer plhs(*), prhs(*)  
integer nlhs, nrhs  
integer mxcreatedoublematrix, mxgetpr  
integer mxgetm, mxgetn  
integer m, n, p  
integer A, B, C  
double precision one, zero, ar, br  
character ch1, ch2
```

```
ch1 = 'N'
ch2 = 'N'
one = 1.0
zero = 0.0

A = mxgetpr(prhs(1))
B = mxgetpr(prhs(2))
m = mxgetm(prhs(1))
p = mxgetn(prhs(1))
n = mxgetn(prhs(2))

plhs(1) = mxcreatedoublematrix(m, n, 0.0)
C = mxgetpr(plhs(1))
call mxcopyprtoreal8(A, ar, 1)
call mxcopyprtoreal8(B, br, 1)

call dgemm (ch1, ch2, m, n, p, one, %val(A), m,
+          %val(B), p, zero, %val(C), m)

return
end
```

Building the Fortran MEX-File

The examples in this section show how to compile and link a Fortran MEX file, `myFortranmexFile.F`, on the platforms supported by MATLAB. In each example, the term `<matlab>` stands for the MATLAB root directory.

Building on the PC. On the PC, using Visual Fortran, you will have to link against a library called `libdflapack.lib`:

```
mex v myFortranMexFile.F
<matlab>/extern/lib/win32/digital/df60/libdflapack.lib
```

Building on Other UNIX Platforms. On the UNIX platforms, you create the MEX file as follows:

```
mex v myFortranMexFile.F
```

Debugging C Language MEX-Files

On most platforms, it is now possible to debug MEX-files while they are running within MATLAB. Complete source code debugging, including setting breakpoints, examining variables, and stepping through the source code line-by-line, is now available.

Note The section entitled, “Troubleshooting” on page 3-28, provides additional information on isolating problems with MEX-files.

To debug a MEX-file from within MATLAB, you must first compile the MEX-file with the `-g` option to `mex`.

```
mex -g filename.c
```

Debugging on UNIX

You need to start MATLAB from within a debugger. To do this, specify the name of the debugger you want to use with the `-D` option when starting MATLAB.

This example shows how to debug `yprime.c` on Solaris using `dbx`, the UNIX debugger.

```
unix> mex -g yprime.c
unix> matlab -Ddbx
<dbx> stop dlopen <matlab>/extern/examples/mex/yprime.mexsol
```

Once the debugger loads MATLAB into memory, you can start it by issuing a `run` command.

```
<dbx> run
```

Now, run the MEX-file that you want to debug as you would ordinarily do (either directly or by means of some other function or script). Before executing the MEX-file, you will be returned to the debugger.

```
>> yprime(1,1:4)
<dbx> stop in `yprime.mexsol`mexFunction
```

Note The tick marks used are back ticks (`), not single quotes (').

You may need to tell the debugger where the MEX-file was loaded or the name of the MEX-file, in which case MATLAB will display the appropriate command for you to use. At this point, you are ready to start debugging. You can list the source code for your MEX-file and set breakpoints in it. It is often convenient to set one at `mexFunction` so that you stop at the beginning of the gateway routine. To proceed from the breakpoint, issue a `continue` command to the debugger.

```
<dbx> cont
```

Once you hit one of your breakpoints, you can make full use of any facilities that your debugger provides to examine variables, display memory, or inspect registers. Refer to the documentation provided with your debugger for information on its use.

Note For information on debugging on other UNIX platforms, access the MathWorks Technical Support Web site at <http://www.mathworks.com/support>.

Debugging on Windows

The following sections provide instructions on how to debug on Microsoft Windows systems using various compilers.

Microsoft Compiler

If you are using the Microsoft compiler:

- 1 Start the Microsoft Visual Studio (Version 5 or 6) by typing at the DOS prompt

```
msdev filename.dll
```

- 2** In the Microsoft environment, from the **Project** menu, select **Settings**. In the window that opens, select the **Debug** tab. This options window contains edit boxes. In the edit box labeled **Executable for debug session**, enter the full path to where MATLAB resides. All other edit boxes should be empty.
- 3** Open the source files and set a break point on the desired line of code by right-clicking with your mouse on the line of code.
- 4** From the **Build** menu, select **Debug**, and click **Go**.
- 5** You will now be able to run your MEX-file in MATLAB and use the Microsoft debugging environment. For more information on how to debug in the Microsoft environment, see the Microsoft Development Studio or Microsoft Visual Studio documentation.

Watcom Compiler

If you are using the Watcom compiler:

- 1** Start the debugger by typing on the DOS command line
`WDW`
- 2** The Watcom Debugger starts and a **New Program** window opens. In this window type the full path to MATLAB. For example,
`c:\matlab\bin\matlab.exe`
Then click **OK**.
- 3** From the **Break** menu, select **On Image Load** and type the name of your MEX-file DLL in capital letters. For example,
`YPRIME`
Then select **ADD** and click **OK** to close the window.
- 4** From the **Run** menu, select **GO**. This should start MATLAB.

- 5 When MATLAB starts, in the command window change directories to where your MEX-file resides and run your MEX-file. If a message similar to the following appears, ignore the message and click **OK**.

```
LDR: Automatic DLL Relocation in matlab.exe
```

```
LDR: DLL filename.dll base <number> relocated due to collision  
with matlab.exe
```

- 6 Open the file you want to debug and set breakpoints in the source code.

Creating Fortran MEX-Files

Fortran MEX-Files (p. 5-2)

MEX-file components and required arguments

Examples of Fortran MEX-Files (p. 5-8)

Sample MEX-files that show how to handle all data types

Advanced Topics (p. 5-34)

Help files, linking multiple files, workspace, managing memory

Debugging Fortran Language
MEX-Files (p. 5-36)

Debugging MEX-file source code from within MATLAB

Fortran MEX-Files

Fortran MEX-files are built by using the `mex` script to compile your Fortran source code with additional calls to API routines.

MEX-files in Fortran, like their C counterparts, can create any data type supported by MATLAB. You can treat Fortran MEX-files, once compiled, exactly like M-functions.

The Components of a Fortran MEX-File

This section discusses the specific elements needed in a Fortran MEX-file. The source code for a Fortran MEX-file, like the C MEX-file, consists of two distinct parts:

- A *computational routine* that contains the code for performing the computations that you want implemented in the MEX-file. Computations can be numerical computations as well as inputting and outputting data.
- A *gateway routine* that interfaces the computational routine with MATLAB by the entry point `mexFunction` and its parameters `prhs`, `nrhs`, `plhs`, `nlhs`, where `prhs` is an array of right-hand input arguments, `nrhs` is the number of right-hand input arguments, `plhs` is an array of left-hand output arguments, and `nlhs` is the number of left-hand output arguments. The gateway calls the computational routine as a subroutine.

The computational and gateway routines may be separate or combined. The following figure, Fortran MEX Cycle, shows how inputs enter an API function, what functions the gateway routine performs, and how output returns to MATLAB.

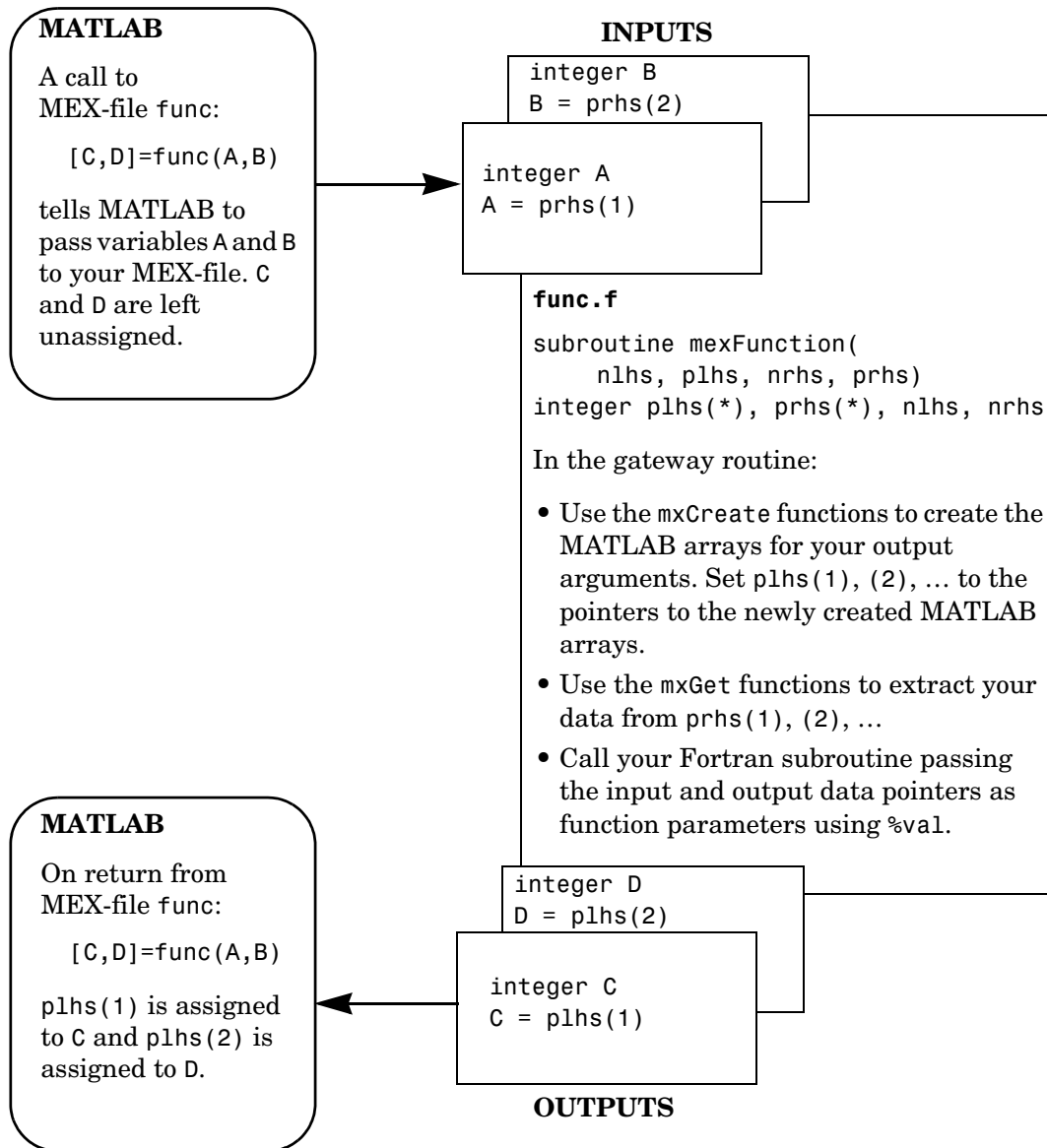

Figure 5-1: Fortran MEX Cycle

The Pointer Concept

The MATLAB API works with a unique data type, the `mxAarray`. Because there is no way to create a new data type in Fortran, MATLAB passes a special identifier, called a pointer, to a Fortran program. You can get information about an `mxAarray` by passing this pointer to various API functions called Access Routines. These access routines allow you to get a native Fortran data type containing exactly the information you want, i.e., the size of the `mxAarray`, whether or not it is a string, or its data contents.

There are several implications when using pointers in Fortran:

- The `%val` construct.

If your Fortran compiler supports the `%val` construct, then there is one type of pointer you can use without requiring an access routine, namely a pointer to data (i.e., the pointer returned by `mXGetPr` or `mXGetPi`). You can use `%val` to pass this pointer's contents to a subroutine, where it is declared as a Fortran double-precision matrix.

If your Fortran compiler does not support the `%val` construct, you must use the `mXCopy__` routines (e.g., `mXCopyPtrToReal8`) to access the contents of the pointer. For more information about the `%val` construct and an example, see the section, "The `%val` Construct" on page 5-7.

- Variable declarations.

To use pointers properly, you must declare them to be the correct size. Declare pointers as `integer*4`.

If your Fortran compiler supports preprocessing with the C preprocessor, you can use the preprocessing stage to map pointers to the appropriate declaration. In UNIX, see the examples ending with `.F` in the `examples` directory for a possible approach.

Caution Declaring a pointer to be the incorrect size may cause your program to crash.

The Gateway Routine

The entry point to the gateway subroutine must be named `mexFunction` and must contain these parameters.

```

subroutine mexFunction(nlhs, plhs, nrhs, prhs)
integer plhs(*), prhs(*)
integer nlhs, nrhs

```

Note Fortran is case-insensitive. This document uses mixed-case function names for ease of reading.

In a Fortran MEX-file, the parameters `nlhs` and `nrhs` contain the number of left- and right-hand arguments with which the MEX-file is invoked. `prhs` is a length `nrhs` array that contains pointers to the right-hand side inputs to the MEX-file, and `plhs` is a length `nlhs` array that contains pointers to the left-hand side outputs that your Fortran function generates.

In the syntax of the MATLAB language, functions have the general form

$$[a,b,c, \dots] = \text{fun}(d,e,f, \dots)$$

where the ellipsis (`...`) denotes additional terms of the same format. The `a, b, c, ...` are left-hand arguments and the `d, e, f, ...` are right-hand arguments.

As an example of the gateway routine, consider invoking a MEX-file from the MATLAB workspace with the command

$$x = \text{fun}(y,z);$$

the MATLAB interpreter calls `mexFunction` with the arguments.

$$nlhs = 1$$

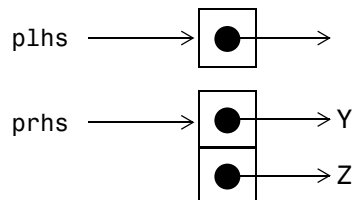
$$nrhs = 2$$

`p1hs` is a 1-element C array where the single element is a null pointer. `prhs` is a 2-element C array where the first element is a pointer to an mxArray named `Y` and the second element is a pointer to an mxArray named `Z`.

The parameter `p1hs` points at nothing because the output `x` is not created until the subroutine executes. It is the responsibility of the gateway routine to create an output array and to set a pointer to that array in `p1hs(1)`. If `p1hs(1)` is left unassigned, MATLAB prints a warning message stating that no output has been assigned.

Note It is possible to return an output value even if `n1hs = 0`. This corresponds to returning the result in the `ans` variable.

The gateway routine should validate the input arguments and call `mexErrMsgTxt` if anything is amiss. This step includes checking the number, type, and size of the input arrays as well as examining the number of output arrays. The examples included later in this section illustrate this technique.

The `mx` functions provide a set of access methods (subroutines) for manipulating MATLAB arrays. These functions are fully documented in the online API reference pages. The `mx` prefix is shorthand for mxArray and it means that the function enables you to access and/or manipulate some of the information in the MATLAB array. For example, `mxGetPr` gets the real data from the MATLAB array. Additional routines are provided for transferring data between MATLAB arrays and Fortran arrays.

The gateway routine must call `mxCreateDoubleMatrix`, `mxCreateSparse`, or `mxCreateString` to create MATLAB arrays of the required sizes in which to return the results. The return values from these calls should be assigned to the appropriate elements of `p1hs`.

The gateway routine may call `mxMalloc` to allocate temporary work arrays for the computational routine if it needs them.

The gateway routine should call the computational routine to perform the desired calculations or operations. There are a number of additional routines that MEX-files can use. These routines are distinguished by the initial characters `mex`, as in `mexCallMATLAB` and `mexErrMsgTxt`.

When a MEX-file completes its task, it returns control to MATLAB. Any MATLAB arrays that are created by the MEX-file that are not returned to MATLAB through the left-hand side arguments are automatically destroyed.

The %val Construct

The %val construct is supported by most, but not all, Fortran compilers. DIGITAL Visual Fortran *does* support the construct. %val causes the value of the variable, rather than the address of the variable, to be passed to the subroutine. If you are using a Fortran compiler that does not support the %val construct, you must copy the array values into a temporary true Fortran array using special routines. For example, consider a gateway routine that calls its computational routine, yprime, by

```
call yprime(%val(y), %val(t), %val(y))
```

If your Fortran compiler does not support the %val construct, you would replace the call to the computational subroutine with

```
C Copy array pointers to local arrays.
  call mxCopyPtrToReal8(t, tr, 1)
  call mxCopyPtrToReal8(y, yr, 4)
C
C Call the computational subroutine.
  call yprime(ypr, tr, yr)
C
C Copy local array to output array pointer.
  call mxCopyReal8ToPtr(ypr, yp, 4)
```

You must also add the following declaration line to the top of the gateway routine.

```
real*8 ypr(4), tr, yr(4)
```

Note that if you use mxCopyPtrToReal8 or any of the other mxCopy__ routines, the size of the arrays declared in the Fortran gateway routine must be greater than or equal to the size of the inputs to the MEX-file coming in from MATLAB. Otherwise mxCopyPtrToReal8 will not work correctly.

Examples of Fortran MEX-Files

The following sections include information and examples describing how to pass and manipulate the different data types when working with MEX-files. These topics include:

- “A First Example — Passing a Scalar”
- “Passing Strings”
- “Passing Arrays of Strings”
- “Passing Matrices”
- “Passing Two or More Inputs or Outputs”
- “Handling Complex Data”
- “Dynamically Allocating Memory”
- “Handling Sparse Matrices”
- “Calling Functions from Fortran MEX-Files”

The MATLAB API provides a set of routines for Fortran that handle double-precision data and strings in MATLAB. For each data type, there is a specific set of functions that you can use for data manipulation.

Note to UNIX Users The example Fortran files in the directory `<matlab>/extern/examples/refbook` have extensions `.F` and `.f`. The distinction between these extensions is that the `.F` files need to be preprocessed.

Note You can find the most recent versions of the example programs from this chapter at the anonymous FTP server,

`ftp://ftp.mathworks.com/pub/tech-support/docexamples/apiguide/R12/refbook`

A First Example – Passing a Scalar

Let's look at a simple example of Fortran code and its MEX-file equivalent. Here is a Fortran computational routine that takes a scalar and doubles it.

```

subroutine timestwo(y, x)
  real*8 x, y
C
  y = 2.0 * x
  return
end

```

Below is the same function written in the MEX-file format.

```

C=====
C   timestwo.f
C   Multiply the input argument by 2.
C
C   This is a MEX-file for MATLAB.
C   Copyright (c) 1984-2000 The MathWorks, Inc.
C   $Revision: 1.12 $
C=====

C   Computational subroutine
subroutine timestwo(y, x)
  real*8 x, y

  y = 2.0 * x
  return
end

C   The gateway routine
subroutine mexFunction(nlhs, plhs, nrhs, prhs)

  integer mxGetM, mxGetN, mxGetPr
  integer mxIsNumeric, mxCreateDoubleMatrix
  integer plhs(*), prhs(*)
  integer x_pr, y_pr
  integer nlhs, nrhs
  integer m, n, size
  real*8 x, y

```

```
C      Check for proper number of arguments.
      if(nrhs .ne. 1) then
          call mexErrMsgTxt('One input required.')
      elseif(nlhs .ne. 1) then
          call mexErrMsgTxt('One output required.')
      endif

C      Get the size of the input array.
      m = mxGetM(prhs(1))
      n = mxGetN(prhs(1))
      size = m*n

C      Check to ensure the input is a number.
      if(mxIsNumeric(prhs(1)) .eq. 0) then
          call mexErrMsgTxt('Input must be a number.')
      endif

C      Create matrix for the return argument.
      plhs(1) = mxCreateDoubleMatrix(m, n, 0)
      x_pr = mxGetPr(prhs(1))
      y_pr = mxGetPr(plhs(1))
      call mxCopyPtrToReal8(x_pr, x, size)

C      Call the computational subroutine.
      call timestwo(y, x)

C      Load the data into y_pr, which is the output to MATLAB.
      call mxCopyReal8ToPtr(y, y_pr, size)

      return
      end
```

To compile and link this example source file, at the MATLAB prompt type

```
mex timestwo.f
```

This carries out the necessary steps to create the MEX-file called `timestwo` with an extension corresponding to the machine type on which you're running. You can now call `timestwo` as if it were an M-function.

```
x = 2;
y = timestwo(x)
y =
     4
```

Passing Strings

Passing strings from MATLAB to a Fortran MEX-file is straightforward. This program accepts a string and returns the characters in reverse order.

```
C=====
C   revord.f
C   Example for illustrating how to copy string data from
C   MATLAB to a Fortran-style string and back again.
C
C   Takes a string and returns a string in reverse order.
C
C   This is a MEX-file for MATLAB.
C   Copyright (c) 1984-2000 The MathWorks, Inc.
C   $Revision: 1.14 $
C=====

C   Computational subroutine
C   subroutine revord(input_buf, strlen, output_buf)
C   character input_buf(*), output_buf(*)
C   integer i, strlen
C
C       do 10 i=1,strlen
C           output_buf(i) = input_buf(strlen-i+1)
10  continue
C       return
C       end
```

Below is the gateway routine that calls the computational routine.

```
C    The gateway routine
      subroutine mexFunction(nlhs, plhs, nrhs, prhs)

      integer mxGetM, mxGetN, mxIsChar
      integer mxCreateString, mxGetString
      integer plhs(*), prhs(*)
      integer nlhs, nrhs
      integer status, strlen
      character*100 input_buf, output_buf

C    Check for proper number of arguments.
      if (nrhs .ne. 1) then
         call mexErrMsgTxt('One input required.')
      elseif (nlhs .gt. 1) then
         call mexErrMsgTxt('Too many output arguments.')

C    The input must be a string.
      elseif(mxIsChar(prhs(1)) .ne. 1) then
         call mexErrMsgTxt('Input must be a string.')

C    The input must be a row vector.
      elseif (mxGetM(prhs(1)) .ne. 1) then
         call mexErrMsgTxt('Input must be a row vector.')
      endif

C    Get the length of the input string.
      strlen = mxGetM(prhs(1))*mxGetN(prhs(1))

C    Get the string contents (dereference the input integer).
      status = mxGetString(prhs(1), input_buf, 100)

C    Check if mxGetString is successful.
      if (status .ne. 0) then
         call mexErrMsgTxt('String length must be less than 100.')
      endif
```

```

C      Initialize output_buf to blanks. This is necessary on some
C      compilers.

      output_buf = ' '

C      Call the computational subroutine.
      call revord(input_buf, strlen, output_buf)

C      Set output_buf to MATLAB mexFunction output.
      plhs(1) = mxCreateString(output_buf)

      return
      end

```

After checking for the correct number of inputs, this MEX-file gateway routine verifies that the input was either a row or column vector string. It then finds the size of the string and places the string into a Fortran character array. Note that in the case of character strings, it is not necessary to copy the data into a Fortran character array by using `mxCopyPtrToCharacter`. In fact, `mxCopyPtrToCharacter` works only with MAT-files. For more information about MAT-files, see Chapter 1, “Importing and Exporting Data.”

For an input string

```
x = 'hello world';
```

typing

```
y = revord(x)
```

produces

```
y =
dlrow olleh
```

Passing Arrays of Strings

Passing arrays of strings adds a slight complication to the example in the previous section, “Passing Strings”. Because MATLAB stores elements of a matrix by column instead of by row, it is essential that the size of the string array be correctly defined in the Fortran MEX-file. The key point is that the row and column sizes as defined in MATLAB must be reversed in the Fortran

MEX-file. Consequently, when returning to MATLAB, the output matrix must be transposed.

This example places a string array/character matrix into MATLAB as output arguments rather than placing it directly into the workspace. Inside MATLAB, call this function by typing

```
passstr;
```

You will get the matrix `mystring` of size 5-by-15. There are some manipulations that need to be done here. The original string matrix is of the size 5-by-15. Because of the way MATLAB reads and orients elements in matrices, the size of the matrix must be defined as `M=15` and `N=5` from the MEX-file. After the matrix is put into MATLAB, the matrix must be transposed.

```
C=====
C   passstr.f
C   Example for illustrating how to pass a character matrix
C   from Fortran to MATLAB.
C
C   Passes a string array/character matrix into MATLAB as
C   output arguments rather than placing it directly into the
C   workspace.
C
C   This is a MEX-file for MATLAB.
C   Copyright (c) 1984-2000 The MathWorks, Inc.
C   $Revision: 1.11 $
C=====

C   The gateway routine
C   subroutine mexFunction(nlhs, plhs, nrhs, prhs)

C
C   integer mxCreateString
C   integer plhs(*), prhs(*)
C   integer nlhs, nrhs, p_str
C   integer i
C   character*75 thestring
C   character*15 string(5)

C
C   Create the strings to be passed into MATLAB.
C   string(1) = 'MATLAB          '
C   string(2) = 'The Scientific '
```



```

        string(3) = 'Computing      '
        string(4) = 'Environment  '
        string(5) = '    by TMW, Inc.'

C      Concatenate the set of 5 strings into a long string.
        thestring = string(1)
        do 10 i=2,6
            thestring = thestring(:((i-1)*15)) // string(i)
10     continue

C      Create the string matrix to be passed into MATLAB.
C      Set the matrix size to be M=15 and N=5.
        p_str = mxcreatestring(thestring)
        call mxSetM(p_str, 15)
        call mxSetN(p_str, 5)

C      Transpose the resulting matrix in MATLAB.
        call mexCallMATLAB(1, plhs, 1, p_str, 'transpose')

        return
    end

```

Typing

```
passstr
```

at the MATLAB prompt produces this result

```

ans =

MATLAB
The Scientific
Computing
Environment
    by TMW, Inc.

```

Passing Matrices

In MATLAB, you can pass matrices into and out of MEX-files written in Fortran. You can manipulate the MATLAB arrays by using `mxGetPr` and `mxGetPi` to assign pointers to the real and imaginary parts of the data stored

in the MATLAB arrays. You can create new MATLAB arrays from within your MEX-file by using `mxCreateDoubleMatrix`.

This example takes a real 2-by-3 matrix and squares each element.

```
C=====
C   matsq.f
C
C   Squares the input matrix
C
C   This is a MEX-file for MATLAB.
C   Copyright (c) 1984-2000 The MathWorks, Inc.
C   $Revision: 1.13 $
C=====

C   Computational subroutine
C   subroutine matsq(y, x, m, n)
C   real*8 x(m,n), y(m,n)
C   integer m, n
C
C   do 20 i=1,m
C       do 10 j=1,n
C           y(i,j)= x(i,j)**2
10      continue
20      continue
C   return
C   end

C   The gateway routine
C   subroutine mexFunction(nlhs, plhs, nrhs, prhs)

C   integer mxGetM, mxGetN, mxGetPr
C   integer mxIsNumeric, mxCreateDoubleMatrix
C   integer plhs(*), prhs(*)
C   integer x_pr, y_pr
C   integer nlhs, nrhs
C   integer m, n, size
C   real*8 x(1000), y(1000)
```

```
C      Check for proper number of arguments.
      if(nrhs .ne. 1) then
          call mexErrMsgTxt('One input required.')
      elseif(nlhs .ne. 1) then
          call mexErrMsgTxt('One output required.')
      endif

C      Get the size of the input array.
      m = mxGetM(prhs(1))
      n = mxGetN(prhs(1))
      size = m*n

C      Column * row should be smaller than 1000.
      if(size.gt.1000) then
          call mexErrMsgTxt('Row *column must be <= 1000.')
      endif

C      Check to ensure the array is numeric (not strings).
      if(mxIsNumeric(prhs(1)) .eq. 0) then
          call mexErrMsgTxt('Input must be a numeric array.')
      endif

C      Create matrix for the return argument.
      plhs(1) = mxCreateDoubleMatrix(m, n, 0)
      x_pr = mxGetPr(prhs(1))
      y_pr = mxGetPr(plhs(1))
      call mxCopyPtrToReal8(x_pr, x, size)

C      Call the computational subroutine.
      call matsq(y, x, m, n)

C      Load the data into y_pr, which is the output to MATLAB.
      call mxCopyReal8ToPtr(y, y_pr, size)

      return
      end
```

After performing error checking to ensure that the correct number of inputs and outputs was assigned to the gateway subroutine and to verify the input was in fact a numeric matrix, `matsq.f` creates a matrix for the argument

returned from the computational subroutine. The input matrix data is then copied to a Fortran matrix by using `mxCopyPtrToReal8`. Now the computational subroutine can be called, and the return argument can then be placed into `y_ptr`, the pointer to the output, using `mxCopyReal8ToPtr`.

For a 2-by-3 real matrix

```
x = [1 2 3; 4 5 6];
```

typing

```
y = matsq(x)
```

produces this result

```
y =  
    1     4     9  
   16    25    36
```

Passing Two or More Inputs or Outputs

The `plhs` and `prhs` parameters are vectors that contain pointers to each left-hand side (output) variable and right-hand side (input) variable. Accordingly, `plhs(1)` contains a pointer to the first left-hand side argument, `plhs(2)` contains a pointer to the second left-hand side argument, and so on. Likewise, `prhs(1)` contains a pointer to the first right-hand side argument, `prhs(2)` points to the second, and so on.

This routine multiplies an input scalar times an input scalar or matrix.

```
C=====
C   xtimesy.f
C
C   Multiply the first input by the second input.
C
C   This is a MEX file for MATLAB.
C   Copyright (c) 1984-2000 The MathWorks, Inc.
C   $Revision: 1.12 $
C=====

C   Computational subroutine
C   subroutine xtimesy(x, y, z, m, n)
C   real*8 x, y(3,3), z(3,3)
```

```
        integer m, n
        do 20 i=1,m
            do 10 j=1,n
                z(i,j) = x*y(i,j)
10         continue
20        continue
        return
        end
```

C The gateway routine
subroutine mexFunction(nlhs, plhs, nrhs, prhs)

```
        integer mxGetM, mxGetN, mxIsNumeric
        integer mxCreateDoubleMatrix
        integer plhs(*), prhs(*)
        integer x_pr, y_pr, z_pr
        integer nlhs, nrhs
        integer m, n, size
        real*8 x, y(3,3), z(3,3)
```

C Check for proper number of arguments.
if (nrhs .ne. 2) then
 call mexErrMsgTxt('Two inputs required.')

elseif (nlhs .ne. 1) then
 call mexErrMsgTxt('One output required.')

endif

C Check to see both inputs are numeric.
if (mxIsNumeric(prhs(1)) .ne. 1) then
 call mexErrMsgTxt('Input #1 is not a numeric.')

elseif (mxIsNumeric(prhs(2)) .ne. 1) then
 call mexErrMsgTxt('Input #2 is not a numeric array.')

endif

C Check that input #1 is a scalar.
m = mxGetM(prhs(1))
n = mxGetN(prhs(1))

```
        if(n .ne. 1 .or. m .ne. 1) then
            call mexErrMsgTxt('Input #1 is not a scalar.')
        endif

C      Get the size of the input matrix.
      m = mxGetM(prhs(2))
      n = mxGetN(prhs(2))
      size = m*n

C      Create matrix for the return argument.
      plhs(1) = mxCreateDoubleMatrix(m, n, 0)
      x_pr = mxGetPr(prhs(1))
      y_pr = mxGetPr(prhs(2))
      z_pr = mxGetPr(plhs(1))

C      Load the data into Fortran arrays.
      call mxCopyPtrToReal8(x_pr, x, 1)
      call mxCopyPtrToReal8(y_pr, y, size)

C      Call the computational subroutine.
      call xtimesy(x, y, z, m, n)

C      Load the output into a MATLAB array.
      call mxCopyReal8ToPtr(z, z_pr, size)

      return
      end
```

As this example shows, creating MEX-file gateways that handle multiple inputs and outputs is straightforward. All you need to do is keep track of which indices of the vectors `prhs` and `plhs` correspond to which input and output arguments of your function. In this example, the input variable `x` corresponds to `prhs(1)` and the input variable `y` to `prhs(2)`.

For an input scalar `x` and a real 3-by-3 matrix,

```
x = 3; y = ones(3);
```

typing

```
z = xtimesy(x, y)
```

yields this result

```
z =
    3    3    3
    3    3    3
    3    3    3
```

Handling Complex Data

MATLAB stores complex double-precision data as two vectors of numbers — one contains the real data and one contains the imaginary data. The API provides two functions, `mxCopyPtrToComplex16` and `mxCopyComplex16ToPtr`, which allow you to copy the MATLAB data to a native `complex*16` Fortran array.

This example takes two complex vectors (of length 3) and convolves them.

```
C=====
C   convec.f
C   Example for illustrating how to pass complex data from
C   MATLAB to FORTRAN (using COMPLEX data type) and back
C   again.
C
C   Convolve two complex input vectors.
C
C   This is a MEX-file for MATLAB.
C   Copyright (c) 1984-2000 The MathWorks, Inc.
C   $Revision: 1.15 $
C=====

C   Computational subroutine
C   subroutine convec(x, y, z, nx, ny)
C   complex*16 x(*), y(*), z(*)
C   integer nx, ny

C   Initialize the output array
C   do 10 i=1,nx+ny-1
C       z(i) = (0.0,0.0)
10  continue
```

```
        do 30 i=1,nx
            do 20 j=1,ny
                z(i+j-1) = z(i+j-1) + x(i) * y(j)
20         continue
30        continue
        return
    end
```

C The gateway routine.

```
subroutine mexFunction(nlhs, plhs, nrhs, prhs)
```

```
integer mxGetPr, mxGetPi, mxGetM, mxGetN
integer mxIsComplex, mxCreateDoubleMatrix
integer plhs(*), prhs(*)
integer nlhs, nrhs
integer mx, nx, my, ny, nz
complex*16 x(100), y(100), z(199)
```

C Check for proper number of arguments.

```
if (nrhs .ne. 2) then
    call mexErrMsgTxt('Two inputs required.')
elseif (nlhs .gt. 1) then
    call mexErrMsgTxt('Too many output arguments.')
endif
```

C Check that inputs are both row vectors.

```
mx = mxGetM(prhs(1))
nx = mxGetN(prhs(1))
my = mxGetM(prhs(2))
ny = mxGetN(prhs(2))
nz = nx+ny-1
```

C Only handle row vector input.

```
if(mx .ne. 1 .or. my .ne. 1) then
    call mexErrMsgTxt('Both inputs must be row vector.')
```

C Check sizes of the two inputs.

```
elseif(nx .gt. 100 .or. ny .gt. 100) then
```



```

        call mexErrMsgTxt('Inputs must have less than 100
                           elements.')

C      Check to see both inputs are complex.
      elseif ((mxIsComplex(prhs(1)) .ne. 1) .or.
+         (mxIsComplex(prhs(2)) .ne. 1)) then
        call mexErrMsgTxt('Inputs must be complex.')
      endif

C      Create the output array.
      plhs(1) = mxCreateDoubleMatrix(1, nz, 1)

C      Load the data into Fortran arrays(native COMPLEX data).
      call mxCopyPtrToComplex16(mxGetPr(prhs(1)),
                               mxGetPi(prhs(1)), x, nx)
      call mxCopyPtrToComplex16(mxGetPr(prhs(2)),
                               mxGetPi(prhs(2)), y, ny)

C      Call the computational subroutine.
      call convec(x, y, z, nx, ny)

C      Load the output into a MATLAB array.
      call mxCopyComplex16ToPtr(z, mxGetPr(plhs(1)),
                               mxGetPi(plhs(1)), nz)

      return
      end

```

Entering these numbers at the MATLAB prompt

```

x = [3 - 1i, 4 + 2i, 7 - 3i]

x =

    3.0000 - 1.0000i    4.0000 + 2.0000i    7.0000 - 3.0000i
y = [8 - 6i, 12 + 16i, 40 - 42i]

y =

    8.0000 - 6.0000i   12.0000 +16.0000i   40.0000 -42.0000i

```

and invoking the new MEX-file

```
z = convec(x, y)
```

results in

```
z =  
  
1.0e+02 *  
  
Columns 1 through 4  
  
0.1800 - 0.2600i    0.9600 + 0.2800i    1.3200 - 1.4400i  
3.7600 - 0.1200i  
  
Column 5  
  
1.5400 - 4.1400i
```

which agrees with the results the built-in MATLAB function `conv.m` produces.

Dynamically Allocating Memory

It is possible to allocate memory dynamically in a Fortran MEX-file, but you must use `%val` to do it. This example takes an input matrix of real data and doubles each of its elements.

```
C=====
C   dblmat.f
C   Example for illustrating how to use %val.
C   Doubles the input matrix. The demo only handles real part
C   of input.
C
C   NOTE: If your Fortran compiler does not support %val,
C   use mxCopy_routine.
C   NOTE: The subroutine compute() is in the file called
C   compute.f.
C
C   This is a MEX-file for MATLAB.
C   Copyright (c) 1984-2000 The MathWorks, Inc.
C   $Revision: 1.13 $
C=====
```

```

C      The gateway subroutine
      subroutine mexfunction(nlhs, plhs, nrhs, prhs)

      integer mxGetPr, mxCreateDoubleMatrix
      integer mxGetM, mxGetN
      integer nlhs, nrhs, plhs(*), prhs(*)
      integer pr_in, pr_out
      integer m_in, n_in, size

      if(nrhs .ne. 1) then
         call mexErrMsgTxt('One input required.')
      endif
      if(nlhs .gt. 1) then
         call mexErrMsgTxt('Less than one output required.')
      endif

      m_in = mxGetM(prhs(1))
      n_in = mxGetN(prhs(1))
      size = m_in * n_in
      pr_in = mxGetPr(prhs(1))
      plhs(1) = mxCreateDoubleMatrix(m_in, n_in, 0)
      pr_out = mxGetPr(plhs(1))

C      Call the computational routine.
      call compute(%val(pr_out), %val(pr_in), size)

      return
      end

```

This is the subroutine that dblmat calls to double the input matrix.

```

C=====
C      compute.f
C
C      This subroutine doubles the input matrix. Your version of
C      compute() may do whaveter you would like it to do.
C
C      This is a MEX-file for MATLAB.

```

```
C Copyright (c) 1984-2000 The MathWorks, Inc.
```

```
C $Revision: 1.3 $
```

```
C=====
```

```
C Computational subroutine
subroutine compute(out_mat, in_mat, size)
integer size, i
real*8 out_mat(*), in_mat(*)

do 10 i=1,size
    out_mat(i) = 2*in_mat(i)
10 continue

return
end
```

For an input 2-by-3 matrix

```
x = [1 2 3; 4 5 6];
```

typing

```
y = dblmat(x)
```

yields

```
y =
    2     4     6
    8    10    12
```

Note The `dblmat.f` example, as well as `fulltosparse.f` and `sincall.f`, are split into two parts, the gateway and the computational subroutine, because of restrictions in some compilers.

Handling Sparse Matrices

The MATLAB API provides a set of functions that allow you to create and manipulate sparse matrices from within your MEX-files. There are special parameters associated with sparse matrices, namely `ir`, `jc`, and `nzmax`. For

information on how to use these parameters and how MATLAB stores sparse matrices in general, refer to the section on “The MATLAB Array” on page 3-4.

Note Sparse array indexing is zero-based, not one-based.

This example illustrates how to populate a sparse matrix.

```

C=====
C   fulltosparse.f
C   Example for illustrating how to populate a sparse matrix.
C   For the purpose of this example, you must pass in a
C   non-sparse 2-dimensional argument of type real double.
C
C   NOTE: The subroutine loadsparse() is in the file called
C   loadsparse.f.
C
C   This is a MEX-file for MATLAB.
C   Copyright (c) 1984-2000 The MathWorks, Inc.
C   $Revision: 1.6 $
C=====

C   The gateway routine.
      subroutine mexFunction(nlhs, plhs, nrhs, prhs)

      integer mxGetPr, mxCreateSparse, mxGetIr, mxGetJc
      integer mxGetM, mxGetN, mxIsComplex, mxIsDouble
      integer loadsparse
      integer plhs(*), prhs(*)
      integer nlhs, nrhs
      integer pr, sr, irs, jcs
      integer m, n, nzmax

C   Check for proper number of arguments.
      if (nrhs .ne. 1) then
         call mexErrMsgTxt('One input argument required.')
      endif

```

```
    if (nlhs .gt. 1) then
        call mexErrMsgTxt('Too many output arguments.')
    endif

C    Check data type of input argument.
    if (mxIsDouble(prhs(1)) .eq. 0) then
        call mexErrMsgTxt('Input argument must be of type double.')
    endif
    if (mxIsComplex(prhs(1)) .eq. 1) then
        call mexErrMsgTxt('Input argument must be real only')
    endif

C    Get the size and pointers to input data.
    m = mxGetM(prhs(1))
    n = mxGetN(prhs(1))
    pr = mxGetPr(prhs(1))

C    Allocate space.
C    NOTE: Assume at most 20% of the data is sparse.
    nzmax = dble(m*n) *.20 + .5

C    NOTE: The maximum number of non-zero elements cannot be less
C    than the number of columns in the matrix.
    if (n .gt. nzmax) then
        nzmax = n
    endif

    plhs(1) = mxCreateSparse(m,n,nzmax,0)
    sr = mxGetPr(plhs(1))
    irs = mxGetIr(plhs(1))
    jcs = mxGetJc(plhs(1))

C    Load the sparse data.
    if (loadsparse(%val(pr), %val(sr), %val(irs), %val(jcs),
+m,n,nzmax) .eq. 1) then
        call mexPrintf('Truncating output, input is > 20%% sparse')
    endif
    return
end
```

This is the subroutine that fulltosparse calls to fill the mxArray with the sparse data.

```

C=====
C   loadsparse.f
C   This is the subfunction called by fulltosparse that fills the
C   mxArray with the sparse data. Your version of
C   loadsparse can operate however you would like it to on the
C   data.
C
C   This is a MEX-file for MATLAB.
C   Copyright (c) 1984-2000 The MathWorks, Inc.
C   $Revision: 1.4 $
C=====

C   Load sparse data subroutine.
      function loadsparse(a, b, ir, jc, m, n, nzmax)
      integer nzmax, m, n
      integer ir(*), jc(*)
      real*8 a(*), b(*)
      integer i, j, k

C   Copy nonzeros.
      k = 1
      do 100 j=1,n
C       NOTE: Sparse indexing is zero based.
          jc(j) = k-1
          do 200 i=1,m
              if (a((j-1)*m+i).ne. 0.0) then
                  if (k .gt. nzmax) then
                      jc(n+1) = nzmax
                      loadsparse = 1
                      goto 300
                  endif
                  b(k) = a((j-1)*m+i)
C       NOTE: Sparse indexing is zero based.
                  ir(k) = i-1
                  k = k+1
              endif
          200 continue
      enddo

```

```
100 continue
C   NOTE: Sparse indexing is zero based.
    jc(n+1) = k-1
    loadsparse = 0
300 return
    end
```

At the MATLAB prompt, entering

```
full = eye(5)
full =
    1    0    0    0    0
    0    1    0    0    0
    0    0    1    0    0
    0    0    0    1    0
    0    0    0    0    1
```

creates a full, 5-by-5 identity matrix. Using `fulltosparse` on the full matrix produces the corresponding sparse matrix.

```
spar = fulltosparse(full)
spar =
    (1,1)    1
    (2,2)    1
    (3,3)    1
    (4,4)    1
    (5,5)    1
```

Calling Functions from Fortran MEX-Files

It's possible to call MATLAB functions, operators, M-files, and even other MEX-files from within your Fortran source code by using the API function `mexCallMATLAB`. This example creates an `mxArray`, passes various pointers to a subfunction to acquire data, and calls `mexCallMATLAB` to calculate the sine function and plot the results.

```
C=====
C   sincall.f
C
C   Example for illustrating how to use mexCallMATLAB.
C
```



```
C   Creates an mxArray and passes its associated pointers (in
C   this demo, only pointer to its real part, pointer to number
C   of rows, pointer to number of columns) to subfunction fill()
C   to get data filled up, then calls mexCallMATLAB to calculate
C   sin function and plot the result.
C
C   NOTE: The subfunction fill() is in the file called fill.f.
C
C   This is a MEX-file for MATLAB.
C   Copyright (c) 1984-2000 The MathWorks, Inc.
C   $Revision: 1.10 $
C =====
C
C   The gateway routine
C   subroutine mexFunction(nlhs, plhs, nrhs, prhs)
C
C       integer mxGetPr, mxCreateDoubleMatrix
C       integer plhs(*), prhs(*)
C       integer lhs(1), rhs(1)
C       integer nlhs, nrhs
C       integer m, n, max
C
C   initialization
C       m = 1
C       n = 1
C       max = 1000
C
C       rhs(1) = mxCreateDoubleMatrix(max, 1, 0)
C
C   Pass the pointer and variable and let fill() fill up data.
C   call fill(%val(mxGetPr(rhs(1))), m, n, max)
C   call mxSetM(rhs(1), m)
C   call mxSetN(rhs(1), n)
C
C   call mexCallMATLAB(1, lhs, 1, rhs, 'sin')
C   call mexCallMATLAB(0, NULL, 1, lhs, 'plot')
C
C   Clean up the unfreed memory after calling mexCallMATLAB.
C   call mxDestroyArray(rhs(1))
C   call mxDestroyArray(lhs(1))
```

```
        return
    end
```

This is the subroutine that sincall calls to fill the mxArray with data.

```
C=====
C   fill.f
C   This is the subfunction called by sincall that fills the
C   mxArray with data. Your version of fill can load your data
C   however you would like.
C
C   This is a MEX-file for MATLAB.
C   Copyright (c) 1984-2000 The MathWorks, Inc.
C   $Revision: 1.3 $
C=====

C   Subroutine for filling up data.
C   subroutine fill(pr, m, n, max)
C   real*8 pr(*)
C   integer i, m, n, max

C       m = max/2
C       n = 1
C       do 10 i=1,m
10          pr(i) = i*(4*3.1415926/max)

C       return
C   end
```

It is possible to use mexCallMATLAB (or any other API routine) from within your computational Fortran subroutine. Note that you can only call most MATLAB functions with double-precision data. M-functions that perform computations, like eig, will not work correctly with data that is not double precision.

Running this example

```
sincall
```

displays the results

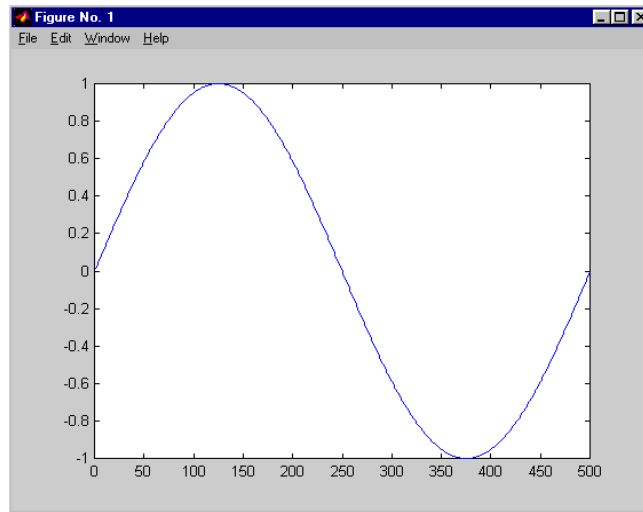

Note It is possible to generate an object of type `mxUNKNOWN_CLASS` using `mexCallMATLAB`. See the example below.

The following example creates an M-file that returns two variables but only assigns one of them a value.

```
function [a,b]=foo[c]  
a=2*c;
```

MATLAB displays the following warning message.

```
Warning: One or more output arguments not assigned during call to  
'foo'.
```

If you then call `foo` using `mexCallMATLAB`, the unassigned output variable will now be of type `mxUNKNOWN_CLASS`.

Advanced Topics

These sections cover advanced features of MEX-files that you can use when your applications require sophisticated MEX-files.

Help Files

Because the MATLAB interpreter chooses the MEX-file when both an M-file and a MEX-file with the same name are encountered in the same directory, it is possible to use M-files for documenting the behavior of your MEX-files. The MATLAB `help` command will automatically find and display the appropriate M-file when help is requested and the interpreter will find and execute the corresponding MEX-file when the function is actually invoked.

Linking Multiple Files

You can combine several source files when building MEX-files. For example,

```
mex circle.f square.o rectangle.f shapes.o
```

is a legal command that operates on the `.f` and `.o` files to create a MEX-file called `circle.ext`, where `ext` is the extension corresponding to the MEX-file type. The name of the resulting MEX-file is taken from the first file in the list.

You may find it useful to use a software development tool like `MAKE` to manage MEX-file projects involving multiple source files. Simply create a `MAKEFILE` that contains a rule for producing object files from each of your source files and then invoke `mex` to combine your object files into a MEX-file. This way you can ensure that your source files are recompiled only when necessary.

Note On UNIX, you must use the `-fortran` switch to the `mex` script if you are linking Fortran objects.

Workspace for MEX-File Functions

Unlike M-file functions, MEX-file functions do not have their own variable workspace. `mexEvalString` evaluates the string in the caller's workspace. In addition, you can use the `mexGetMatrix` and `mexPutMatrix` routines to get and put variables into the caller's workspace.

Memory Management

MATLAB now implicitly destroys (by calling `mxDestroyArray`) any arrays created by a MEX-file that are not returned in the left-hand side list (`plhs()`). Consequently, any misconstructed arrays left over at the end of a MEX-file's execution have the potential to cause memory errors.

In general, we recommend that MEX-files destroy their own temporary arrays and clean up their own temporary memory. For additional information on memory management techniques, see the sections “Memory Management” on page 4-37 and “Memory Management Compatibility Issues” on page 3-33.

Debugging Fortran Language MEX-Files

On most platforms, it is now possible to debug MEX-files while they are running within MATLAB. Complete source code debugging, including setting breakpoints, examining variables, and stepping through the source code line-by-line, is now available.

Note The section on “Troubleshooting” on page 3-28 provides additional information on isolating problems with MEX-files.

To debug a MEX-file from within MATLAB, you must first compile the MEX-file with the `-g` option to `mex`.

```
mex -g filename.f
```

Debugging on UNIX

You must start MATLAB from within a debugger. To do this, specify the name of the debugger you want to use with the `-D` option when starting MATLAB. For example, to use `dbx`, the UNIX debugger, type

```
matlab -Ddbx
```

Once the debugger loads MATLAB into memory, you can start it by issuing a run command. Now, from within MATLAB, enable MEX-file debugging by typing

```
dbmex on
```

at the MATLAB prompt. Then run the MEX-file you want to debug as you would ordinarily (either directly or by means of some other function or script). Before executing the MEX-file, you will be returned to the debugger.

You may need to tell the debugger where the MEX-file was loaded or the name of the MEX-file, in which case MATLAB will display the appropriate command for you to use. At this point, you are ready to start debugging. You can list the source code for your MEX-file and set break points in it. It is often convenient to set one at `mexFunction` so that you stop at the beginning of the gateway routine.

Note The name `mexFunction` may be slightly altered by the compiler (i.e., it may have an underscore appended). To determine how this symbol appears in a given MEX-file, use the UNIX command

```
nm <MEX-file> | grep -i mexfunction
```

To proceed from the breakpoint, issue a `continue` command to the debugger.

Once you hit one of your breakpoints, you can make full use of any facilities your debugger provides to examine variables, display memory, or inspect registers. Refer to the documentation provided with your debugger for information on its use.

If you are at the MATLAB prompt and want to return control to the debugger, you can issue the command

```
dbmex stop
```

which allows you to gain access to the debugger so you can set additional breakpoints or examine source code. To resume execution, issue a `continue` command to the debugger.

Debugging on Windows

Compaq Visual Fortran

If you are using the Compaq (or DIGITAL) Visual Fortran compiler, you use the Microsoft debugging environment to debug your program.

- 1 Start the Microsoft Visual Studio by typing at the DOS prompt

```
msdev filename.dll
```
- 2 In the Microsoft environment, from the **Project** menu, select **Settings**. In the window that opens, select the **Debug** tab. This options window contains edit boxes. In the edit box labeled **Executable for debug session**, enter the full path where MATLAB resides. All other edit boxes should be empty.
- 3 Open the source files and set a break point on the desired line of code by right-clicking with your mouse on the line of code.

- 4 From the **Build** menu, select **Debug**, and click **Go**.
- 5 You will now be able to run your MEX-file in MATLAB and use the Microsoft debugging environment. For more information on how to debug in the Microsoft environment, see the Microsoft Development Studio documentation.

Calling MATLAB from C and Fortran Programs

The MATLAB engine library is a set of routines that allows you to call MATLAB from your own programs, thereby employing MATLAB as a computation engine. MATLAB engine programs are C or Fortran programs that communicate with a separate MATLAB process via pipes, on UNIX, and through a Component Object Model (COM) interface, on Windows. There is a library of functions provided with MATLAB that allows you to start and end the MATLAB process, send data to and from MATLAB, and send commands to be processed in MATLAB.

Using the MATLAB Engine (p. 6-2)

What type of applications is the MATLAB engine useful for, and what functions are available to use with it

Examples of Calling Engine Functions (p. 6-5)

Example programs that call MATLAB from C or Fortran, and that attach to an existing MATLAB session

Compiling and Linking Engine Programs (p. 6-16)

Compiling and linking on UNIX and Windows

Using the MATLAB Engine

Some of the things you can do with the MATLAB engine are:

- Call a math routine, for example, to invert an array or to compute an FFT from your own program. When employed in this manner, MATLAB is a powerful and programmable mathematical subroutine library.
- Build an entire system for a specific task, for example, radar signature analysis or gas chromatography, where the front end (GUI) is programmed in C and the back end (analysis) is programmed in MATLAB, thereby shortening development time.

The MATLAB engine operates by running in the background as a separate process from your own program. This offers several advantages:

- On UNIX, the MATLAB engine can run on your machine, or on any other UNIX machine on your network, including machines of a different architecture. Thus you could implement a user interface on your workstation and perform the computations on a faster machine located elsewhere on your network. The description of the `engOpen` function offers further information.
- Instead of requiring that all of MATLAB be linked to your program (a substantial amount of code), only a small engine communication library is needed.

The Engine Library

The engine library contains the following routines for controlling the MATLAB computation engine. Their names all begin with the three-letter prefix `eng`. These tables list all the available engine functions and their purposes.

C Engine Routines

Function	Purpose
<code>engOpen</code>	Start up MATLAB engine
<code>engClose</code>	Shut down MATLAB engine
<code>engGetVariable</code>	Get a MATLAB array from the MATLAB engine

C Engine Routines

Function	Purpose
engPutVariable	Send a MATLAB array to the MATLAB engine
engEvalString	Execute a MATLAB command
engOutputBuffer	Create a buffer to store MATLAB text output
engOpenSingleUse	Start a MATLAB engine session for single, nonshared use
engGetVisible	Determine visibility of MATLAB engine session
engSetVisible	Show or hide MATLAB engine session

Fortran Engine Routines

Function	Purpose
engOpen	Start up MATLAB engine
engClose	Shut down MATLAB engine
engGetVariable	Get a MATLAB array from the MATLAB engine
engPutVariable	Send a MATLAB array to the MATLAB engine
engEvalString	Execute a MATLAB command
engOutputBuffer	Create a buffer to store MATLAB text output

The MATLAB engine also uses the `mx` prefixed API routines discussed in Chapter 4, “Creating C Language MEX-Files” and Chapter 5, “Creating Fortran MEX-Files.”

Communicating with MATLAB

On UNIX, the engine library communicates with the MATLAB engine using pipes, and, if needed, rsh for remote execution. On Microsoft Windows, the engine library communicates with MATLAB using a Component Object Model (COM) interface. Chapter 8, “COM and DDE Support (Windows Only)” contains a detailed description of COM.

GUI-Intensive Applications

If you have graphical user interface (GUI) intensive applications that execute a lot of callbacks through the MATLAB engine, you should force these callbacks to be evaluated in the context of the base workspace. Use `evalin` to specify that the base workspace is to be used in evaluating the callback expression, as follows.

```
engEvalString(ep, "evalin('base', expression)")
```

Specifying the base workspace in this manner ensures that MATLAB will process the callback correctly and return results for that call.

This does not apply to computational applications that do not execute callbacks.

Examples of Calling Engine Functions

This section contains examples that illustrate how to call engine functions from C and Fortran programs. The examples cover the following topics:

- “Calling MATLAB from a C Application”
- “Calling MATLAB from a Fortran Application”
- “Attaching to an Existing MATLAB Session”

It is important to understand the sequence of steps you must follow when using the engine functions. For example, before using `engPutVariable`, you must create the matrix and populate it.

After reviewing these examples, follow the instructions in “Compiling and Linking Engine Programs” on page 6-16 to build the application and test it. By building and running the application, you will ensure that your system is properly configured for engine applications.

Calling MATLAB from a C Application

This program, `engdemo.c`, illustrates how to call the engine functions from a stand-alone C program. For the Windows version of this program, see `engwindemo.c` in the `<matlab>\extern\examples\eng_mat` directory. Engine examples, like the MAT-file examples, are located in the `eng_mat` directory.

```
/*
 * engdemo.c
 *
 * This is a simple program that illustrates how to call the
 * MATLAB engine functions from a C program.
 *
 * Copyright (c) 1984-2000 The MathWorks, Inc.
 * Revision: 1.8 $
 */
#include <stdlib.h>
#include <stdio.h>
#include <string.h>
#include "engine.h"
#define BUFSIZE 256
```

```
int main()

{
    Engine *ep;
    mxArray *T = NULL, *result = NULL;
    char buffer[BUFSIZE];
    double time[10] = {0.0, 1.0, 2.0, 3.0, 4.0, 5.0, 6.0, 7.0,
                      8.0, 9.0};

    /*
     * Start the MATLAB engine locally by executing the string
     * "matlab".
     *
     * To start the session on a remote host, use the name of
     * the host as the string rather than \0.
     *
     * For more complicated cases, use any string with whitespace,
     * and that string will be executed literally to start MATLAB.
     */
    if (!(ep = engOpen("\0"))) {
        fprintf(stderr, "\nCan't start MATLAB engine\n");
        return EXIT_FAILURE;
    }

    /*
     * PART I
     *
     * For the first half of this demonstration, we will send data
     * to MATLAB, analyze the data, and plot the result.
     */

    /*
     * Create a variable for our data.
     */
    T = mxCreateDoubleMatrix(1, 10, mxREAL);
    memcpy((void *)mxGetPr(T), (void *)time, sizeof(time));

    /*
     * Place the variable T into the MATLAB workspace.
     */
    engPutVariable(ep, "T", T);
}
```

```
/*
 * Evaluate a function of time, distance = (1/2)g.*t.^2
 * (g is the acceleration due to gravity).
 */
engEvalString(ep, "D = .5.*(-9.8).*T.^2;");

/*
 * Plot the result.
 */
engEvalString(ep, "plot(T,D);");
engEvalString(ep, "title('Position vs. Time for a falling
                        object');");
engEvalString(ep, "xlabel('Time (seconds)');");
engEvalString(ep, "ylabel('Position (meters)');");

/*
 * Use fgetc() to make sure that we pause long enough to be
 * able to see the plot.
 */
printf("Hit return to continue\n\n");
fgetc(stdin);

/*
 * We're done for Part I! Free memory, close MATLAB engine.
 */
printf("Done for Part I.\n");
mxDestroyArray(T);
engEvalString(ep, "close;");

/*
 * PART II
 *
 * For the second half of this demonstration, we will request
 * a MATLAB string, which should define a variable X.  MATLAB
 * will evaluate the string and create the variable.  We
 * will then recover the variable, and determine its type.
 */

/*
```

```
    * Use engOutputBuffer to capture MATLAB output, so we can
    * echo it back.
    */

engOutputBuffer(ep, buffer, BUFSIZE);
while (result == NULL) {
    char str[BUFSIZE];

    /*
     * Get a string input from the user.
     */
    printf("Enter a MATLAB command to evaluate. This command
           should\n");
    printf("create a variable X. This program will then
           determine\n");
    printf("what kind of variable you created.\n");
    printf("For example: X = 1:5\n");
    printf(">> ");

    fgets(str, BUFSIZE-1, stdin);

    /*
     * Evaluate input with engEvalString.
     */
    engEvalString(ep, str);

    /*
     * Echo the output from the command. First two characters
     * are always the double prompt (>>).
     */
    printf("%s", buffer+2);

    /*
     * Get result of computation.
     */
    printf("\nRetrieving X...\n");
    if ((result = engGetVariable(ep, "X")) == NULL)
        printf("Oops! You didn't create a variable X.\n\n");
    else {
        printf("X is class %s\t\n", mxGetClassName(result));
    }
}
```



```

    }
}

/*
 * We're done! Free memory, close MATLAB engine and exit.
 */
printf("Done!\n");
mxDestroyArray(result);
engClose(ep);

return EXIT_SUCCESS;
}

```

The first part of this program launches MATLAB and sends it data. MATLAB then analyzes the data and plots the results.

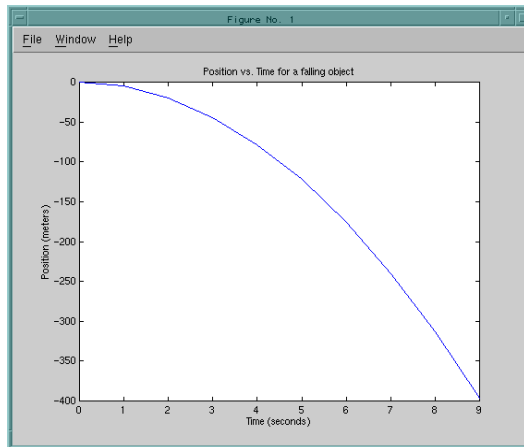

The program then continues with

```
Press Return to continue
```

Pressing **Return** continues the program.

```
Done for Part I.
```

```
Enter a MATLAB command to evaluate. This command should
create a variable X. This program will then determine
what kind of variable you created.
```

```
For example: X = 1:5
```

Entering `X = 17.5` continues the program execution.

```
X = 17.5
```

```
X =
```

```
17.5000
```

```
Retrieving X...  
X is class double  
Done!
```

Finally, the program frees memory, closes the MATLAB engine, and exits.

Calling MATLAB from a Fortran Application

This program, `fengdemo.f`, illustrates how to call the engine functions from a stand-alone Fortran program.

```
C=====
C   fengdemo.f
C
C   This program illustrates how to call the MATLAB
C   Engine functions from a Fortran program.
C
C Copyright (c) 1984-2000 by The MathWorks, Inc.
C $Revision: 1.9 $
C=====

      program main

      integer engOpen, engClose, engEvalString
      integer engGetVariable, engPutVariable
      integer mxGetPr, mxCreateDoubleMatrix
      integer ep, T, D
      double precision time(10), dist(10)
      integer temp, status
      data time / 1.0, 2.0, 3.0, 4.0, 5.0, 6.0, 7.0, 8.0,
               9.0, 10.0 /
```

```

ep = engOpen('matlab ');

if (ep .eq. 0) then
    write(6,*) 'Can''t start MATLAB engine'
    stop
endif

T = mxCreateDoubleMatrix(1, 10, 0)
call mxCopyReal8ToPtr(time, mxGetPr(T), 10)
C
C Place the variable T into the MATLAB workspace.
C
status = engPutVariable(ep, 'T', T)

if (status .ne. 0) then
    write(6,*) 'engPutVariable failed'
    stop
endif

C
C Evaluate a function of time, distance = (1/2)g.*t.^2
C (g is the acceleration due to gravity).
C
if (engEvalString(ep, 'D = .5.*(-9.8).*T.^2;') .ne. 0) then
    write(6,*) 'engEvalString failed'
    stop
endif

C
C Plot the result.
C
if (engEvalString(ep, 'plot(T,D);') .ne. 0) then
    write(6,*) 'engEvalString failed'
    stop
endif

if (engEvalString(ep, 'title(''Position vs. Time'')')
.ne. 0) then
    write(6,*) 'engEvalString failed'
    stop
endif

```

```
        if (engEvalString(ep, 'xlabel(''Time (seconds)'')')
        .ne. 0) then
            write(6,*) 'engEvalString failed'
            stop
        endif
        if (engEvalString(ep, 'ylabel(''Position (meters)'')')
        .ne. 0) then
            write(6,*) 'engEvalString failed'
            stop
        endif
C
C      Read from console to make sure that we pause long enough to
C      be able to see the plot.
C
        print *, 'Type 0 <return> to Exit'
        print *, 'Type 1 <return> to continue'

        read(*,*) temp

        if (temp.eq.0) then
            print *, 'EXIT!'
            stop
        end if

        if (engEvalString(ep, 'close;') .ne. 0) then
            write(6,*) 'engEvalString failed'
            stop
        endif

        D = engGetVariable(ep, 'D')
        call mxCopyPtrToReal8(mxGetPr(D), dist, 10)
        print *, 'MATLAB computed the following distances:'
        print *, '  time(s)  distance(m)'
        do 10 i=1,10
            print 20, time(i), dist(i)
20          format(' ', G10.3, G10.3)
10      continue

        call mxDestroyArray(T)
        call mxDestroyArray(D)
```

```
status = engClose(ep)

if (status .ne. 0) then
    write(6,*) 'engClose failed'
    stop
endif

stop
end
```

Executing this program launches MATLAB, sends it data, and plots the results.

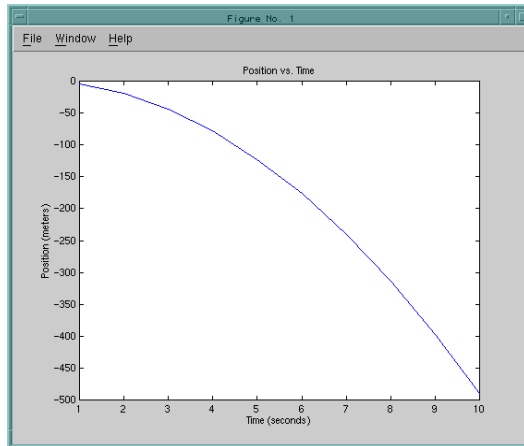

The program continues with

```
Type 0 <return> to Exit
Type 1 <return> to continue
```

Entering 1 at the prompt continues the program execution.

```
1
MATLAB computed the following distances:
time(s)  distance(m)
1.00     -4.90
2.00     -19.6
3.00     -44.1
4.00     -78.4
5.00     -123.
6.00     -176.
7.00     -240.
8.00     -314.
9.00     -397.
10.0     -490.
```

Finally, the program frees memory, closes the MATLAB engine, and exits.

Attaching to an Existing MATLAB Session

You can make a MATLAB engine program attach to a MATLAB session that is already running by starting the MATLAB session with `/Automation` in the command line. When you make a call to `engOpen`, it will then connect to this existing session. You should only call `engOpen` once, as any `engOpen` calls will now connect to this one MATLAB session.

The `/Automation` option also causes the command window to be minimized. You must open it manually.

Note For more information on the `/Automation` command line argument, see “Additional Automation Server Information” on page 8-79. For information about the Component Object Model interfaces used by MATLAB, see “Introducing MATLAB COM Integration” on page 8-2.

For example:

- 1 Shut down any MATLAB sessions.
- 2 From the **Start** button on the Windows menu bar, click **Run**.

3 In the **Open** field, type

```
d:\matlab\bin\win32\matlab.exe /Automation
```

where d:\matlab\bin\win32 represents the path to the MATLAB executable.

4 Click **OK**. This starts MATLAB.

5 In MATLAB, change directories to \$MATLAB/extern/examples/eng_mat, where \$MATLAB is the MATLAB root directory.

6 Compile the engwindemo.c example.

7 Run the engwindemo program by typing at the MATLAB prompt

```
!engwindemo
```

This does not start another MATLAB session, but rather uses the MATLAB session that is already open.

Note On the UNIX platform, you cannot make a MATLAB engine program use a MATLAB session that is already running.

Compiling and Linking Engine Programs

To produce an executable version of an engine program, you must compile it and link it with the appropriate library. This section describes the steps required to compile and link engine programs on UNIX and Windows systems. It begins by looking at a special consideration for compilers that do not mask floating-point exceptions. Topics covered are:

- “Masking Floating-Point Exceptions” on page 6-16
- “Compiling and Linking on UNIX” on page 6-17
- “Compiling and Linking on Windows” on page 6-19
- “Required Files from Third-Party Sources” on page 6-19
- “Working Directly with Unicode” on page 6-21

Masking Floating-Point Exceptions

Certain mathematical operations can result in nonfinite values. For example, division by zero results in the nonfinite IEEE value, `inf`. A floating-point exception occurs when such an operation is performed. Because MATLAB uses an IEEE model that supports nonfinite values such as `inf` and `NaN`, MATLAB disables, or *masks*, floating-point exceptions.

Some compilers do not mask floating-point exceptions by default. This causes engine programs built with such compilers to terminate when a floating-point exception occurs. Consequently, you need to take special precautions when using these compilers to mask floating-point exceptions so that your engine application will perform properly.

Note MATLAB based applications should never get floating-point exceptions. If you do get a floating-point exception, verify that any third party libraries that you link against do not enable floating-point exception handling.

The only compiler and platform on which you need to mask floating-point exceptions is the Borland C++ compiler on Windows.

Borland C++ Compiler on Windows

To mask floating-point exceptions when using the Borland C++ compiler on the Windows platform, you must add some code to your program. Include the following at the beginning of your `main()` or `WinMain()` function, before any calls to MATLAB API functions.

```
#include <float.h>
.
.
.
_control187(MCW_EM,MCW_EM);
.
.
.
```

Compiling and Linking on UNIX

Under UNIX at runtime, you must tell the system where the API shared libraries reside. These sections provide the necessary UNIX commands depending on your shell and system architecture.

Setting Runtime Library Path

In C shell, the command to set the library path is

```
setenv LD_LIBRARY_PATH $MATLAB/bin/$ARCH
```

where `$MATLAB` is the MATLAB root directory and `$ARCH` is your system architecture on which MATLAB is supported.

In Bourne shell, the commands to set the library path are

```
LD_LIBRARY_PATH=$MATLAB/bin/$ARCH:$LD_LIBRARY_PATH
export LD_LIBRARY_PATH
```

where `$MATLAB` is the MATLAB root directory and `$ARCH` is your system architecture on which MATLAB is supported.

Setting Runtime Library Path on Macintosh

On the Macintosh platform, the library path variable is called `DYLD_LIBRARY_PATH`. Use the following commands to set the library path:

In C shell, the command to set the library path is

```
setenv DYLD_LIBRARY_PATH
      $MATLAB/bin/mac:$MATLAB/sys/os/mac:$DYLD_LIBRARY_PATH
```

In Bourne shell, the commands to set the library path are

```
DYLD_LIBRARY_PATH=
      $MATLAB/bin/mac:$MATLAB/sys/os/mac:$DYLD_LIBRARY_PATH
export DYLD_LIBRARY_PATH
```

Platform-Specific Environment Variables

Note that the environment variable (`LD_LIBRARY_PATH` in this example) varies on several platforms. This table lists the different environment variable names you should use on these systems.

Environment Variable Names

Architecture	Environment Variable
HP-UX	SHLIB_PATH
Mac OS X	DYLD_LIBRARY_PATH

It is convenient to place these commands in a startup script such as `~/ .cshrc` for C shell or `~/ .profile` for Bourne shell.

Using the Options File

MATLAB provides an options file, `engopts.sh`, that lets you use the `mex` script to easily compile and link engine applications. For example, to compile and link the `engdemo.c` example, first copy the file

```
$MATLAB/extern/examples/eng_mat/engdemo.c
```

(where `$MATLAB` is the MATLAB root directory) to a directory that is writable, and then use the following command to build it:

```
mex -f $MATLAB/bin/engopts.sh engdemo.c
```

If you need to modify the options file for your particular compiler or platform, use the `-v` switch to view the current compiler and linker settings and then make the appropriate changes in a local copy of the `engopts.sh` file.

Compiling and Linking on Windows

To compile and link engine programs, use the `mex` script with an engine options file. The engine options files reside in `$MATLAB\bin\win32\mexopts` and are named `*engmatopts.bat`, where `*` represents the compiler type (e.g., `bcc` for Borland, `wat` for Watcom, etc.).

For example, to compile and link the stand-alone engine application `engwindemo.c` using MSVC Version 7.1 on Windows, first copy the file

```
$MATLAB\extern\examples\eng_mat\engwindemo.c
```

(where `$MATLAB` is the MATLAB root directory) to a directory that is writable, and then use the following command to build it:

```
mex -f $MATLAB\bin\win32\mexopts\msvc71engmatopts.bat ...  
engwindemo.c
```

If you need to modify the options file for your particular compiler, use the `-v` switch to view the current compiler and linker settings and then make the appropriate changes in the options file.

Required Files from Third-Party Sources

MATLAB requires the following data and library files for building any engine application. You must also distribute these files along with any engine application that you deploy to another system:

Third-Party Data Files

When building an engine application on your system or deploying an engine application to some other system, make sure that the appropriate Unicode data file is installed in the `$MATLAB/bin/$ARCH` directory. MATLAB uses this file to support Unicode.

For systems that order bytes in a big-endian manner, use

```
icudt24b.dat.
```

For systems that order bytes in a little-endian manner, use

```
icudt24l.dat.
```

Third-Party Libraries

When building an engine application on your system or deploying an engine application to some other system, make sure that the appropriate libraries are installed in the `$MATLAB/bin/$ARCH` directory (where `$MATLAB` is the MATLAB root directory and `$ARCH` is your system architecture).

On UNIX	On Windows
-----	-----
<code>libeng.{so dylib sl}</code>	<code>libeng.dll</code>
<code>libmx.{so dylib sl}</code>	<code>libmx.dll</code>
<code>libut.{so dylib sl}</code>	<code>libut.dll</code>

In addition to these libraries, you must also have all third-party library files that `libeng` depends on. MATLAB uses these additional libraries to support Unicode character encoding and data compression in MAT-files. These library files must reside in the same directory as `libmx` and `libut`.

You can determine what most of these libraries are using the platform-specific methods described below.

On Linux, Solaris, or HP-UX Systems

Type the following command:

```
ldd -d libeng.{so|sl}
```

On Macintosh Systems

Type the following command:

```
otool -L libeng.dylib
```

On Windows Systems

Download the Dependency Walker utility from the following Web site

```
http://www.dependencywalker.com/
```

and then drag-and-drop the file `$MATLAB/bin/win32/libeng.dll` into Depends window. (`$MATLAB` represents the MATLAB root directory).

Working Directly with Unicode

If you need to manipulate Unicode text directly in your application, version 2.4 of International Components for Unicode (ICU) is freely available online from the IBM Corporation Web site at:

`http://oss.software.ibm.com/icu/download/2.4/index.html`

Calling Java from MATLAB

Using Java from MATLAB: An Overview
(p. 7-2)

How you can benefit from using the MATLAB Java interface

Bringing Java Classes and Methods into
MATLAB (p. 7-6)

Using Java built-in, third-party, or your own classes

Creating and Using Java Objects (p. 7-15)

Constructing and working with Java objects

Invoking Methods on Java Objects (p. 7-24)

Calling syntax, static methods, querying MATLAB about methods

Working with Java Arrays (p. 7-34)

How MATLAB represents Java arrays and how to work with them

Passing Data to a Java Method (p. 7-52)

How to pass MATLAB data types into Java

Handling Data Returned from a Java
Method (p. 7-62)

How to handle data types returned by Java

Introduction to Programming Examples
(p. 7-68)

Introduction and links to sample programs that use the MATLAB interface to Java

Example – Reading a URL (p. 7-69)

Open a connection to a Web site and read text from the site using a buffered stream reader

Example – Finding an Internet Protocol
Address (p. 7-72)

Call methods on an `InetAddress` object to get hostname and IP address information

Example – Communicating Through a
Serial Port (p. 7-74)

Create a `SerialPort` object and configure the port using methods provided by that class

Example – Creating and Using a Phone
Book (p. 7-79)

Create a phone book using a data dictionary that operates using key/value pairs in a hash table

Using Java from MATLAB: An Overview

This section covers the following topics:

- “Java Interface Is Integral to MATLAB” on page 7-2
- “Benefits of the MATLAB Java Interface” on page 7-2
- “Who Should Use the MATLAB Java Interface” on page 7-2
- “To Learn More About Java Programming” on page 7-3
- “Platform Support for the Java Virtual Machine” on page 7-3
- “Using a Different Version of the Java JVM” on page 7-3

Java Interface Is Integral to MATLAB

Every installation of MATLAB includes a Java Virtual Machine (JVM), so that you can use the Java interpreter via MATLAB commands, and you can create and run programs that create and access Java objects. For information on MATLAB installation, see the MATLAB installation documentation for your platform.

Benefits of the MATLAB Java Interface

The MATLAB Java interface enables you to:

- Access Java API (application programming interface) class packages that support essential activities such as I/O and networking. For example, the `URL` class provides convenient access to resources on the internet
- Access third-party Java classes
- Easily construct Java objects in MATLAB
- Call Java object methods, using either Java or MATLAB syntax
- Pass data between MATLAB variables and Java objects

Who Should Use the MATLAB Java Interface

The MATLAB Java interface is intended for all MATLAB users who want to take advantage of the special capabilities of the Java programming language. For example:

- You need to access, from MATLAB, the capabilities of available Java classes.

- You are familiar with object-oriented programming in Java or in another language, such as C++.
- You are familiar with MATLAB object-oriented classes, or with MATLAB MEX-files.

To Learn More About Java Programming

For a complete description of the Java language and for guidance in object-oriented software design and programming, you'll need to consult outside resources. For example, these recently published books may be helpful:

- *Java in a Nutshell* (Fourth Edition), by David Flanagan
- *Teach Yourself Java in 21 Days*, by Lemay and Perkins

Another place to find information is the JavaSoft Web site.

`http://www.javasoft.com`

For other suggestions on object-oriented programming resources, see:

- *Object Oriented Software Construction*, by Bertrand Meyer
- *Object Oriented Analysis and Design with Applications*, by Grady Booch

Platform Support for the Java Virtual Machine

To find out which version of the Java Virtual Machine (JVM) is being used by MATLAB on your platform, type the following at the MATLAB prompt.

```
version -java
```

Using a Different Version of the Java JVM

MATLAB ships with one specific version of the Java Virtual Machine (JVM) and uses this version by default with the MATLAB interface to Java. This section describes how to download and select a version other than the default.

Note MATLAB is only fully supported on the JVM that it ships with. Some components may not work properly under a different version of the JVM.

To change the JVM version that MATLAB uses, follow these steps:

- 1 “Download the JVM Version You Want to Use” on page 7-4.
- 2 “Locate the Root of the Run-time Path for this Version” on page 7-4.
- 3 “Set the MATLAB_JAVA Environment Variable to this Path” on page 7-4.

When you have enabled a different version of the JVM, you can verify that MATLAB is using this version by entering the `version -java` command documented in the previous section.

Download the JVM Version You Want to Use

You can download the Java Virtual Machine from the Web site <http://java.sun.com/j2se/downloads.html>.

If you are using Linux, go to the Web site <http://www.blackdown.org/java-linux/mirrors.html>, and choose the version required by your processor.

Locate the Root of the Run-time Path for this Version

To get MATLAB to use the version you have just downloaded, you must first find the root of the run-time path for this JVM, and then set the MATLAB_JAVA environment variable to that path. To locate the JVM run-time path, find the directory in the Java installation tree that is one level up from the directory containing the file `rt.jar`. This may be a subdirectory of the main JDK install directory. (If you cannot find `rt.jar`, look for the file `classes.zip`.)

For example, if the JDK is installed in `D:\jdk1.2.1` on Windows and the `rt.jar` file is in `D:\jdk1.2.1\jre\lib`, you would set MATLAB_JAVA to the directory one level up from that: `D:\jdk1.2.1\jre`.

On UNIX, if the JDE is installed in `/usr/opencv/java/jre/lib` and the `rt.jar` is in `/usr/opencv/java/jre/lib`, set MATLAB_JAVA to the path `/usr/opencv/java/jre`.

Set the MATLAB_JAVA Environment Variable to this Path

The way you set or modify the value of the MATLAB_JAVA variable depends on which platform you are running MATLAB on.

Windows NT/2000/XP. To set MATLAB_JAVA on Windows NT, Windows 2000, or Windows XP,

- 1** Click **Settings** in the **Start** Menu
- 2** Choose **Control Panel**
- 3** Click **System**
- 4** Choose the **Environment** tab on Windows NT or the **Advanced** tab on Windows 2000 or XP, and then click the **Environment Variables** button.
- 5** You now can set (or add) the MATLAB_JAVA system environment variable to the path of your JVM.

For UNIX/Linux. To set MATLAB_JAVA on UNIX or Linux systems,

Use the setenv command, as shown here:

```
setenv MATLAB_JAVA <path to JVM>
```

Bringing Java Classes and Methods into MATLAB

You can draw from an extensive collection of existing Java classes or create your own class definitions to use with MATLAB. This section explains how to go about finding the class definitions that you need or how to create classes of your own design. Once you have the classes you need, defined in either individual `.class` files, packages, or Java Archive files, you will see how to make them available within the MATLAB environment. This section also covers how to specify the native method libraries used by Java.

This section addresses the following topics:

- “Sources of Java Classes”
- “Defining New Java Classes” on page 7-7
- “The Java Class Path” on page 7-7
- “Making Java Classes Available to MATLAB” on page 7-10
- “Loading Java Class Definitions” on page 7-12
- “Simplifying Java Class Names” on page 7-13
- “Locating Native Method Libraries” on page 7-14

Sources of Java Classes

There are three main sources of Java classes that you can use in MATLAB:

- **Java built-in classes**

The Java language includes general-purpose class packages, such as `java.awt`. See your Java language documentation for descriptions of these packages.

- **Third-party classes**

There are a number of packages of special-purpose Java classes that you can use.

- **User-defined classes**

You can define new Java classes or subclasses of existing classes. You need to use a Java development environment to do this, as explained in the following section.

Defining New Java Classes

To define new Java classes and subclasses of existing classes, you must use a Java development environment, external to MATLAB, that supports Java version 1.4.2. You can download the development kit from the web site at Sun Microsystems, (<http://java.sun.com/j2se/>). The Sun site also provides documentation for the Java language and classes that you will need for development.

After you create class definitions in `.java` files, use your Java compiler to produce `.class` files from them. The next step is to make the class definitions in those `.class` files available for you to use in MATLAB.

The Java Class Path

MATLAB loads Java class definitions from files that are on the *Java class path*. The class path is a series of file and directory specifications that MATLAB uses to locate class definitions. When loading a particular Java class, MATLAB searches files and directories in the order they occur on the class path until a file is found that contains that class definition. The first definition that is found ends the search.

The Java class path consists of two segments: the *static path* and *dynamic path*. The static path is loaded at the start of each MATLAB session and cannot be changed without restarting MATLAB. The dynamic path can be loaded and modified at any time during a session using MATLAB functions. MATLAB always searches the static path before the dynamic path.

Note Java classes on the static path should not have dependencies on classes on the dynamic path.

You can view these two path segments using the `javaclasspath` function:

```
javaclasspath
```

```
STATIC JAVA PATH
```

```
D:\Sys0\Java\util.jar  
D:\Sys0\Java\widgets.jar  
D:\Sys0\Java\beans.jar
```

```
.  
.
  
DYNAMIC JAVA PATH
  
User4:\Work\Java\ClassFiles
User4:\Work\Java\mywidgets.jar
  
.
.
```

You will probably want to use both the static and dynamic paths:

- Put the Java class definitions that are more stable on the static class path. Classes defined on the static path load somewhat faster than those on the dynamic path.
- Put the Java class definitions that you are likely to modify on the dynamic class path. You will be able to make changes to the class definitions on this path without having to restart MATLAB.

The Static Path

The static Java class path is loaded at the start of each MATLAB session from the file `classpath.txt`. The static path offers better Java class loading performance than the dynamic path. However, to modify the static path you need to edit the file `classpath.txt` and then restart MATLAB.

Finding and Editing `classpath.txt`. The default `classpath.txt` file resides in the `toolbox\local` subdirectory of your MATLAB root directory:

```
[matlabroot ' \toolbox\local\classpath.txt' ]
ans =
    \\sys07\matlab\toolbox\local\classpath.txt
```

To make changes in the static path that will affect all users who share this same MATLAB root, you can edit this file in `toolbox\local`. If you want to make changes that will not affect anyone else, copy `classpath.txt` to your own startup directory and edit the file there. When MATLAB starts up, it looks for `classpath.txt` first in your startup directory, and then in the default location. It uses the file it finds first.

To see which `classpath.txt` file is currently being used by your MATLAB environment, use the `which` function:

which `classpath.txt`

To edit either the default file or the copy you have made in your own directory, enter the following command in MATLAB:

```
edit classpath.txt
```

Note MATLAB reads `classpath.txt` only upon startup. If you edit `classpath.txt` or change your `.class` files while MATLAB is running, you must restart MATLAB to put those changes into effect.

Special Symbols in `classpath.txt`. You can designate special tokens or macros in the `classpath.txt` file using a leading dollar sign, (e.g., `$matlabroot` or `$jre_home`). However, this can cause problems if you use this sign in any of your class directory paths. For example, the following path string does not correctly represent the path to a directory named `hello$world`:

```
d:\\applications\\hello$world
```

You must use two consecutive dollar signs in `classpath.txt` to represent a single `$` character. So, to correctly specify the directory path shown above, you need to use the following text:

```
d:\\applications\\hello$$world
```

The Dynamic Path

The dynamic Java class path can be loaded at any time during a MATLAB session using the `javaclasspath` function. You can define the dynamic path (using `javaclasspath`), modify the path (using `javaaddpath` and `javarmppath`), and refresh the Java class definitions for all classes on the dynamic path (using `clear java`) without restarting MATLAB. See the function reference pages for more information on how to use these functions.

Although the dynamic path offers more flexibility in changing the path, you may notice that Java classes that are on the dynamic path load more slowly than those on the static path.

Making Java Classes Available to MATLAB

To make your third-party and user-defined Java classes available in MATLAB, place them on either the static or dynamic Java class path, as described in the previous section, “The Java Class Path” on page 7-7.

- For classes that you want on the static path, edit the `classpath.txt` file.
- For classes that you want on the dynamic path, use either the `javaclasspath` or `javaaddpath` function.

Making Individual (Unpackaged) Classes Available

To make individual classes (classes that are not part of a package) available in MATLAB, specify the full path to the directory you want to use for the `.class` file(s).

For example, to make available your compiled Java classes in the file `d:\work\javaclasses\test.class`, add the following entry to the static or dynamic class path:

```
d:\work\javaclasses
```

To put this directory on the static class path, add the above line to the default copy (in `toolbox\local`) or your own local copy of `classpath.txt`. See “Finding and Editing `classpath.txt`” on page 7-8.

To put this on the dynamic class path, use the following command:

```
javaaddpath d:\work\javaclasses
```

Making Entire Packages Available

To access one or more classes belonging to a package, you need to make the entire package available to MATLAB. To do this, specify the full path to the *parent directory of the highest-level directory* of the package path. This directory is the first component in the package name.

For example, if your Java class package `com.mw.tbx.ini` has its classes in directory `d:\work\com\mw\tbx\ini`, add the following directory to your static or dynamic class path:

```
d:\work
```

Making Classes in a JAR File Available

You can use the `jar` (Java Archive) tool to create a JAR file, containing multiple Java classes and packages in a compressed ZIP format. For information on `jar` and JAR files, consult your Java development documentation or the JavaSoft web site. See also “To Learn More About Java Programming” on page 7-3.

To make the contents of a JAR file available for use in MATLAB, specify the full path, *including full filename*, for the JAR file.

Note The `classpath.txt` requirement for JAR files is different than that for `.class` files and packages, for which you do not specify any filename.

For example, to make available the JAR file `e:\java\classes\utilpkg.jar`, add the following file specification to your static or dynamic class path:

```
e:\java\classes\utilpkg.jar
```

Loading Java Class Definitions

Normally, MATLAB loads a Java class automatically when your code first uses it, (for example, when you call its constructor). However, there is one exception that you should be aware of.

When you use the `which` function on methods defined by Java classes, the function only acts on the classes currently loaded into the MATLAB working environment. In contrast, `which` always operates on MATLAB classes, whether or not they are loaded.

Determining Which Classes Are Loaded

At any time during a MATLAB session, you can obtain a listing of all the Java classes that are currently loaded. To do so, you use the `inmem` function, in the following form.

```
[M,X,J] = inmem
```

This function returns the list of Java classes in output argument `J`. (It also returns in `M` the names of all currently loaded `M`-files, and in `X` the names of all currently loaded `MEX`-files.)

Here's a sample of output from the `inmem` function.

```
[m,x,j] = inmem
m =
    'isequal'
    'isunix'
    'fullfile'
    'filesep'
    .
    .
    .
    'matlabrc'
x =
    'getprofil'
```

```
j =  
    'java.awt.Frame'  
    'com.mathworks.ide.desktop.MLDesktop'
```

Simplifying Java Class Names

Your MATLAB commands can refer to any Java class by its fully qualified name, which includes its package name. For example, the following are fully qualified names:

- `java.lang.String`
- `java.util.Enumeration`

A fully qualified name can be rather long, making commands and functions, such as constructors, cumbersome to edit and to read. You can refer to classes by the class name alone (without a package name) if you, first, import the fully qualified name into MATLAB.

The `import` command has the following forms.

```
import pkg_name.*           % Import all classes in package  
import pkg_name1.* pkg_name2.* % Import multiple packages  
import class_name           % Import one class  
import                      % Display current import list  
L = import                  % Return current import list
```

MATLAB adds all classes that you import to a list called the *import list*. You can see what classes are on that list by typing `import`, without any arguments. Your code can refer to any class on the list by class name alone.

When called from a function, `import` adds the specified classes to the import list in effect for that function. When invoked at the command prompt, `import` uses the base import list for your MATLAB environment.

For example, suppose a function contains the following statements.

```
import java.lang.String  
import java.util.* java.awt.*  
import java.util.Enumeration
```

Code that follows the import statements above can now refer to the `String`, `Frame`, and `Enumeration` classes without using the package names.

```
str = String('hello');      % Create java.lang.String object
frm = Frame;                % Create java.awt.Frame object
methods Enumeration        % List java.util.Enumeration methods
```

To clear the list of imported Java classes, invoke the command

```
clear import
```

Locating Native Method Libraries

Java classes can dynamically load native methods using the Java method `java.lang.System.loadLibrary("LibFile")`. In order for the JVM to locate the specified library file, the directory containing it must be on the Java Library Path. This path is established when MATLAB launches the JVM at startup, and is based on the contents of the file

```
$matlab/toolbox/local/librarypath.txt
```

(where `$matlab` is the MATLAB root directory represented by the MATLAB keyword `matlabroot`).

You can augment the search path for native method libraries by editing the `librarypath.txt` file. Follow these guidelines when editing this file:

- Specify each new directory on a line by itself.
- Specify only the directory names, not the names of the DLL files. The `LoadLibrary` call does this for you.
- To simplify the specification of directories in cross-platform environments, you can use any of these macros: `$matlabroot`, `$arch`, and `$jre_home`.

Creating and Using Java Objects

In MATLAB, you create a Java object by calling one of the constructors of that class. You then use commands and programming statements to perform operations on these objects. You can also save your Java objects to a MAT-file and, in subsequent sessions, reload them into MATLAB.

This section addresses the following topics:

- “Constructing Java Objects”
- “Concatenating Java Objects” on page 7-17
- “Saving and Loading Java Objects to MAT-Files” on page 7-19
- “Finding the Public Data Fields of an Object” on page 7-20
- “Accessing Private and Public Data” on page 7-21
- “Determining the Class of an Object” on page 7-23

Constructing Java Objects

You construct Java objects in MATLAB by calling the Java class constructor, which has the same name as the class. For example, the following constructor creates a `Frame` object with the title 'Frame A' and the other properties with their default values.

```
frame = java.awt.Frame('Frame A');
```

Displaying the new object `frame` shows the following.

```
frame =  
java.awt.Frame[frame0,0,0,0x0,invalid,hidden,layout=  
java.awt.BorderLayout,resizable,title=Frame A]
```

All of the programming examples in this chapter contain Java object constructors. For example, the sample code for Reading a URL creates a `java.net.URL` object with the constructor

```
url = java.net.URL(...  
    'http://archive.ncsa.uiuc.edu/demoweb/')
```

Using the `javaObject` Function

Under certain circumstances, you may need to use the `javaObject` function to construct a Java object. The following syntax invokes the Java constructor for class, `class_name`, with the argument list that matches `x1, ..., xn`, and returns a new object, `J`.

```
J = javaObject('class_name',x1,...,xn);
```

For example, to construct and return a Java object of class `java.lang.String`, you use

```
strObj = javaObject('java.lang.String','hello');
```

Using the `javaObject` function enables you to:

- Use classes that have names that exceed the maximum length of a MATLAB identifier. (Call the `namelengthmax` function to obtain the maximum identifier length.)
- Specify the class for an object at run-time, for example, as input from an application user

The default MATLAB constructor syntax requires that no segment of the input class name be longer than `namelengthmax` characters. (A *class name segment* is any portion of the class name before, between, or after a dot. For example, there are three segments in class, `java.lang.String`.) Any class name segment that exceeds `namelengthmax` characters is truncated by MATLAB. In the rare case where you need to use a class name of this length, you must use `javaObject` to instantiate the class.

The `javaObject` function also allows you to specify the Java class for the object being constructed at run-time. In this situation, you call `javaObject` with a string variable in place of the class name argument.

```
class = 'java.lang.String';  
text = 'hello';  
strObj = javaObject(class, text);
```

In the usual case, when the class to instantiate is known at development time, it is more convenient to use the MATLAB constructor syntax. For example, to create a `java.lang.String` object, you would use

```
strObj = java.lang.String('hello');
```

Note Typically, you will not need to use `javaObject`. The default MATLAB syntax for instantiating a Java class is somewhat simpler and is preferable for most applications. Use `javaObject` primarily for the two cases described above.

Java Objects Are References in MATLAB

In MATLAB, Java objects are *references* and do not adhere to MATLAB copy-on-assignment and pass-by-value rules. For example,

```
origFrame = java.awt.Frame;  
setSize(origFrame, 800, 400);  
newFrameRef = origFrame;
```

In the third statement above, the variable `newFrameRef` is a second reference to `origFrame`, not a copy of the object. In any code following the example above, any change to the object at `newFrameRef` also changes the object at `origFrame`. This effect occurs whether the object is changed by MATLAB code, or by Java code.

The following example shows that `origFrame` and `newFrameRef` are both references to the same entity. When the size of the frame is changed via one reference (`newFrameRef`), the change is reflected through the other reference (`origFrame`), as well.

```
setSize(newFrameRef, 1000, 800);  
  
getSize(origFrame)  
ans =  
java.awt.Dimension[width=1000,height=800]
```

Concatenating Java Objects

You can concatenate Java objects in the same way that you concatenate native MATLAB data types. You use either the `cat` function or the square bracket operators to tell MATLAB to assemble the enclosed objects into a single object.

Concatenating Objects of the Same Class

If all of the objects being operated on are of the same Java class, then the concatenation of those objects produces an array of objects from the same class.

In the following example, the `cat` function concatenates two objects of the class `java.awt.Point`. The class of the result is also `java.awt.Point`.

```
point1 = java.awt.Point(24,127);
point2 = java.awt.Point(114,29);

cat(1, point1, point2)
ans =
java.awt.Point[]:
 [1x1 java.awt.Point]
 [1x1 java.awt.Point]
```

Concatenating Objects of Unlike Classes

When you concatenate objects of unlike classes, MATLAB finds one class from which all of the input objects inherit, and makes the output an instance of this class. MATLAB selects the lowest common parent in the Java class hierarchy as the output class.

For example, concatenating objects of `java.lang.Byte`, `java.lang.Integer`, and `java.lang.Double` yields an object of `java.lang.Number`, since this is the common parent to the three input classes.

```
byte = java.lang.Byte(127);
integer = java.lang.Integer(52);
double = java.lang.Double(7.8);

[byte; integer; double]

ans =
java.lang.Number[]:
 [ 127]
 [ 52]
 [7.8000]
```

If there is no common, lower level parent, then the resultant class is `java.lang.Object`, which is the root of the entire Java class hierarchy.

```
byte = java.lang.Byte(127);  
point = java.awt.Point(24,127);
```

```
[byte; point]
```

```
ans =  
java.lang.Object[]:  
 [          127]  
 [1x1 java.awt.Point]
```

Saving and Loading Java Objects to MAT-Files

Use the MATLAB `save` function to save a Java object to a MAT-file. Use the `load` function to load it back into MATLAB from that MAT-file. To save a Java object to a MAT-file, and to load the object from the MAT-file, make sure that the object and its class meet all of the following criteria:

- The class implements the `Serializable` interface (part of the Java API), either directly or by inheriting it from a parent class. Any embedded or otherwise referenced objects must also implement `Serializable`.
- The definition of the class is not changed between saving and loading the object. Any change to the data fields or methods of a class prevents the loading (deserialization) of an object that was constructed with the old class definition.
- Either the class does not have any transient data fields, or the values in transient data fields of the object to be saved are not significant. Values in transient data fields are never saved with the object.

If you define your own Java classes, or subclasses of existing classes, you can follow the criteria above to enable objects of the class to be saved and loaded in MATLAB. For details on defining classes to support serialization, consult your Java development documentation. (See also “To Learn More About Java Programming” on page 7-3).

Finding the Public Data Fields of an Object

To list the public fields that belong to a Java object, use the `fieldnames` function, which takes either of these forms.

```
names = fieldnames(obj)
names = fieldnames(obj, '-full')
```

Calling `fieldnames` without `'-full'` returns the names of all the data fields (including inherited) on the object. With the `'-full'` qualifier, `fieldnames` returns the full description of the data fields defined for the object, including type, attributes, and inheritance information.

Suppose, for example, that you constructed a `Frame` object with

```
frame = java.awt.Frame;
```

To obtain the full description of the data fields on `frame`, you could use the command

```
fieldnames(frame, '-full')
```

Sample output from this command follows.

```
ans =
'static final int WIDTH
  % Inherited from java.awt.image.ImageObserver'
'static final int HEIGHT
  % Inherited from java.awt.image.ImageObserver'
[1x74 char]
'static final int SOMEBITS
  % Inherited from java.awt.image.ImageObserver'
'static final int FRAMEBITS
  % Inherited from java.awt.image.ImageObserver'
'static final int ALLBITS
  % Inherited from java.awt.image.ImageObserver'
'static final int ERROR
  % Inherited from java.awt.image.ImageObserver'
'static final int ABORT
  % Inherited from java.awt.image.ImageObserver'
'static final float TOP_ALIGNMENT
  % Inherited from java.awt.Component'
'static final float CENTER_ALIGNMENT
  % Inherited from java.awt.Component'
```

```
'static final float BOTTOM_ALIGNMENT
    % Inherited from java.awt.Component'
'static final float LEFT_ALIGNMENT
    % Inherited from java.awt.Component'
'static final float RIGHT_ALIGNMENT
    % Inherited from java.awt.Component'
.
.
.
```

Accessing Private and Public Data

Java API classes provide accessor methods you can use to read from and, where allowed, to modify *private* data fields. These are sometimes referred to as *get* and *set* methods, respectively.

Some Java classes have *public* data fields, which your code can read or modify directly. To access these fields, use the syntax `object.field`.

Examples

The `java.awt.Frame` class provides an example of access to both private and public data fields. This class has the read accessor method `getSize`, which returns a `java.awt.Dimension` object. The `Dimension` object has data fields `height` and `width`, which are public and therefore directly accessible. The following example shows MATLAB commands accessing this data.

```
frame = java.awt.Frame;
frameDim = getSize(frame);
height = frameDim.height;
frameDim.width = 42;
```

The programming examples in this chapter also contain calls to data field accessors. For instance, the sample code for “Example – Finding an Internet Protocol Address” on page 7-72 uses calls to accessors on a `java.net.InetAddress` object.

```
hostname = address.getHostByName;
ipaddress = address.getHostAddress;
```

Accessing Data from a Static Field

In Java, a static data field is a field that applies to an entire class of objects. Static fields are most commonly accessed in relation to the class name itself in Java. For example, the code below accesses the `WIDTH` field of the `Frame` class by referring to it in relation to the package and class names, `java.awt.Frame`, rather than an object instance.

```
width = java.awt.Frame.WIDTH;
```

In MATLAB, you can use that same syntax. Or you can refer to the `WIDTH` field in relation to an instance of the class. The example shown here creates an instance of `java.awt.Frame` called `frameObj`, and then accesses the `WIDTH` field using the name `frameObj` rather than the package and class names.

```
frame = java.awt.Frame('Frame A');  
  
width = frame.WIDTH  
width =  
    1
```

Assigning to a Static Field

You can assign values to static Java fields by using a static set method of the class, or by making the assignment in reference to an instance of the class. For more information, see the previous section, “Accessing Data from a Static Field”. You can assign value to the field `staticFieldName` in the example below by referring to this field in reference to an instance of the class.

```
objectName = java.className;  
objectName.staticFieldName = value;
```

Note MATLAB does not allow assignment to static fields using the class name itself.

Determining the Class of an Object

To find the class of a Java object, use the query form of the MATLAB function, `class`. After execution of the following example, `frameClass` contains the name of the package and class that Java object `frame` instantiates.

```
frameClass = class(frame)
frameClass =
java.awt.Frame
```

Because this form of `class` also works on MATLAB objects, it does not, in itself, tell you whether it is a Java class. To determine the type of class, use the `isjava` function, which has the form

```
x = isjava(obj)
```

`isjava` returns 1 if `obj` is Java, and 0 if it is not.

```
isjava(frame)
ans =
1
```

To find out whether or not an object is an instance of a specified class, use the `isa` function, which has the form

```
x = isa(obj, 'class_name')
```

`isa` returns 1 if `obj` is an instance of the class named '`class_name`', and 0 if it is not. Note that '`class_name`' can be a MATLAB built-in or user-defined class, as well as a Java class.

```
isa(frame, 'java.awt.Frame')
ans =
1
```

Invoking Methods on Java Objects

This section explains how to invoke an object's methods in MATLAB. It also covers how to obtain information related to the methods that you're using and how MATLAB handles certain types of nonstandard situations.

This section addresses the following topics:

- “Using Java and MATLAB Calling Syntax”
- “Invoking Static Methods on Java Classes” on page 7-26
- “Obtaining Information About Methods” on page 7-27
- “Java Methods That Affect MATLAB Commands” on page 7-31
- “How MATLAB Handles Undefined Methods” on page 7-32
- “How MATLAB Handles Java Exceptions” on page 7-33

Using Java and MATLAB Calling Syntax

To call methods on Java objects, you can use the Java syntax

```
object.method(arg1,...,argn)
```

In the following example, `frame` is the `java.awt.Frame` object created above, and `getTitle` and `setTitle` are methods of that object.

```
frame.setTitle('Sample Frame')

title = frame.getTitle
title =
Sample Frame
```

Alternatively, you can call Java object (nonstatic) methods with the MATLAB syntax

```
method(object, arg1,...,argn)
```

With MATLAB syntax, the `java.awt.Frame` example above becomes

```
setTitle(frame, 'Sample Frame')

title = getTitle(frame)
title =
Sample Frame
```

All of the programming examples in this chapter contain invocations of Java object methods. For example, the code for Reading a URL contains a call, using MATLAB syntax, to the `openStream` method on a `java.net.URL` object, `url`.

```
is = openStream(url)
```

In another example, the code for “Example – Creating and Using a Phone Book” on page 7-79 contains a call, using Java syntax, to the `load` method on a `java.util.Properties` object, `pb_htable`.

```
pb_htable.load(FIS);
```

Using the `javaMethod` Function on Nonstatic Methods

Under certain circumstances, you may need to use the `javaMethod` function to call a Java method. The following syntax invokes the method, `method_name`, on Java object `J` with the argument list that matches `x1, . . . , xn`. This returns the value `X`.

```
X = javaMethod('method_name', J, x1, . . . , xn);
```

For example, to call the `startsWith` method on a `java.lang.String` object passing one argument, use

```
gAddress = java.lang.String('Four score and seven years ago');
str = java.lang.String('Four score');

javaMethod('startsWith', gAddress, str)
ans =
    1
```

Using the `javaMethod` function enables you to

- Use methods that have names that exceed the maximum length of a MATLAB identifier. (Call the `namelengthmax` function to obtain the maximum identifier length.)
- Specify the method you want to invoke at run-time, for example, as input from an application user.

The only way to invoke a method whose name is longer than `namelengthmax` characters is to use `javaMethod`. The Java and MATLAB calling syntax does not accept method names of this length.

With `javaMethod`, you can also specify the method to be invoked at run-time. In this situation, your code calls `javaMethod` with a string variable in place of the `method_name` argument. When you use `javaMethod` to invoke a static method, you can also use a string variable in place of the class name argument.

Note Typically, you will not need to use `javaMethod`. The default MATLAB syntax for invoking a Java method is somewhat simpler and is preferable for most applications. Use `javaMethod` primarily for the two cases described above.

Invoking Static Methods on Java Classes

To invoke a static method on a Java class, use the Java invocation syntax

```
class.method(arg1, ..., argn)
```

For example, call the `isNaN` static method on the `java.lang.Double` class.

```
java.lang.Double.isNaN(2.2)
```

Alternatively, you can apply static method names to instances of a class. In this example, the `isNaN` static method is referenced in relation to the `dblObject` instance of the `java.lang.Double` class.

```
dblObject = java.lang.Double(2.2);
```

```
dblObject.isNaN  
ans =  
    0
```

Several of the programming examples in this chapter contain examples of static method invocation. For example, the code for `Communicating Through a Serial Port` contains a call to static method `getPortIdentifier` on Java class `javax.comm.CommPortIdentifier`.

```
commPort =  
javax.comm.CommPortIdentifier.getPortIdentifier('COM1');
```

Using the `javaMethod` Function on Static Methods

The `javaMethod` function was introduced in section “Using the `javaMethod` Function on Nonstatic Methods” on page 7-25. You can also use this function to call static methods.

The following syntax invokes the static method, `method_name`, in class, `class_name`, with the argument list that matches `x1, . . . , xn`. This returns the value `X`.

```
X = javaMethod('method_name', 'class_name', x1, . . . , xn);
```

For example, to call the static `isNaN` method of the `java.lang.Double` class on a double value of 2.2, you use

```
javaMethod('isNaN', 'java.lang.Double', 2.2);
```

Using the `javaMethod` function to call static methods enables you to:

- Use methods that have names that exceed the maximum length of a MATLAB identifier. (Call the `namelengthmax` function to obtain the maximum identifier length.)
- Specify method and class names at run-time, for example, as input from an application user

Obtaining Information About Methods

MATLAB offers several functions to help obtain information related to the Java methods you are working with. You can request a list of all of the methods that are implemented by any class. The list may be accompanied by other method information such as argument types and exceptions. You can also request a listing of every Java class that you loaded into MATLAB that implements a specified method.

Methodsview: Displaying a Listing of Java Methods

If you want to know what methods are implemented by a particular Java (or MATLAB) class, use the `methodsview` function in MATLAB. Specify the class name (along with its package name, for Java classes) in the command line. If you have imported the package that defines this class, then the class name alone will suffice.

The following command lists information on all methods in the `java.awt.MenuItem` class.

```
methodsview java.awt.MenuItem
```

A new window appears, listing one row of information for each method in the class. This is what the `methodsview` display looks like. The fieldnames shown at the top of the window are described following the figure.

Qualifiers	Return Type	Name	Arguments
		MenuItem	()
		MenuItem	(java.lang.String)
		MenuItem	(java.lang.String,java.awt.MenuShortcut)
synchronized	void	addActionListener	(java.awt.event.ActionListener)
	void	addNotify	()
	void	deleteShortcut	()
synchronized	void	disable	()
	void	dispatchEvent	(java.awt.AWTEvent)
synchronized	void	enable	()
	void	enable	(boolean)
	boolean	equals	(java.lang.Object)
	java.lang.String	getActionCommand	()
	java.lang.Class	getClass	()
	java.awt.Font	getFont	()
	java.lang.String	getLabel	()
	java.lang.String	getName	()
	java.awt.MenuContainer	getParent	()
	java.awt.peer.MenuComponentPeer	getPeer	()
	java.awt.MenuShortcut	getShortcut	()
	int	hashCode	()
	boolean	isEnabled	()
	void	notify	()
	void	notifyAll	()

Each row in the window displays up to six fields of information describing the method. The table below lists the fields displayed in the methodsview window along with a description and examples of each field type.

Table 7-1: Fields Displayed in the Methodsview Window

Field Name	Description	Examples
Qualifiers	Method type qualifiers	abstract, synchronized
Return Type	Data type returned by the method	void, java.lang.String
Name	Method name	addActionListener, dispatchEvent
Arguments	Arguments passed to method	boolean, java.lang.Object
Other	Other relevant information	throws java.io.IOException
Parent	Parent of the specified class	java.awt.MenuComponent

Using the Methods Function on Java Classes

In addition to methodsview, the MATLAB `methods` function, that returns information on methods of MATLAB classes, will also work on Java classes. You can use any of the following forms of this command.

```
methods class_name
methods class_name -full
n = methods('class_name')
n = methods('class_name', '-full')
```

Use `methods` without the `'-full'` qualifier to return the names of all the methods (including inherited methods) of the class. Names of overloaded methods are listed only once.

With the `'-full'` qualifier, `methods` returns a listing of the method names (including inherited methods) along with attributes, argument lists, and inheritance information on each. Each overloaded method is listed separately.

For example, display a full description of all methods of the `java.awt.Dimension` object.

```
methods java.awt.Dimension -full

Methods for class java.awt.Dimension:
Dimension()
Dimension(java.awt.Dimension)
Dimension(int,int)
java.lang.Class getClass() % Inherited from java.lang.Object
int hashCode() % Inherited from java.lang.Object
boolean equals(java.lang.Object)
java.lang.String toString()
void notify() % Inherited from java.lang.Object
void notifyAll() % Inherited from java.lang.Object
void wait(long) throws java.lang.InterruptedException
    % Inherited from java.lang.Object
void wait(long,int) throws java.lang.InterruptedException
    % Inherited from java.lang.Object
void wait() throws java.lang.InterruptedException
    % Inherited from java.lang.Object
java.awt.Dimension getSize()
void setSize(java.awt.Dimension)
void setSize(int,int)
```

Determining What Classes Define a Method

You can use the `which` function to display the fully qualified name (package and class name) of a method implemented by a *loaded* Java class. With the `-all` qualifier, the `which` function finds all classes with a method of the name specified.

Suppose, for example, that you want to find the package and class name for the `concat` method, with the `String` class currently loaded. Use the command

```
which concat
java.lang.String.concat % String method
```

If the `java.lang.String` class has not been loaded, the same `which` command would give the output

```
which concat
concat not found.
```

If you use `which -all` for the method `equals`, with the `String` and `java.awt.Frame` classes loaded, you see the following display.

```
which -all equals
java.lang.String.equals           % String method
java.awt.Frame.equals            % Frame method
com.mathworks.ide.desktop.MLDesktop.equals % MLDesktop method
```

The `which` function operates differently on Java classes than it does on MATLAB classes. MATLAB classes are always displayed by `which`, whether or not they are loaded. This is not true for Java classes. You can find out which Java classes are currently loaded by using the command `[m,x,j]=inmem`, described in “Determining Which Classes Are Loaded” on page 7-12.

For a description of how Java classes are loaded, see “Making Java Classes Available to MATLAB” on page 7-10.

Java Methods That Affect MATLAB Commands

MATLAB commands that operate on Java objects and arrays make use of the methods that are implemented within, or inherited by, these objects’ classes. There are some MATLAB commands that you can alter somewhat in behavior by changing the Java methods that they rely on.

Changing the Effect of `disp` and `display`

You can use the `disp` function to display the value of a variable or an expression in MATLAB. Terminating a command line without a semicolon also calls the `disp` function. You can also use `disp` to display a Java object in MATLAB.

When `disp` operates on a Java object, MATLAB formats the output using the `toString` method of the class to which the object belongs. If the class does not implement this method, then an inherited `toString` method is used. If no intermediate ancestor classes define this method, it uses the `toString` method defined by the `java.lang.Object` class. You can override inherited `toString` methods in classes that you create by implementing such a method within your class definition. In this way, you can change the way MATLAB displays information regarding the objects of the class.

Changing the Effect of `isequal`

The MATLAB `isequal` function compares two or more arrays for equality in type, size, and contents. This function can also be used to test Java objects for equality.

When you compare two Java objects using `isequal`, MATLAB performs the comparison using the Java method, `equals`. MATLAB first determines the class of the objects specified in the command, and then uses the `equals` method implemented by that class. If it is not implemented in this class, then an inherited `equals` method is used. This will be the `equals` method defined by the `java.lang.Object` class if no intermediate ancestor classes define this method.

You can override inherited `equals` methods in classes that you create by implementing such a method within your class definition. In this way, you can change the way MATLAB performs comparison of the members of this class.

Changing the Effect of `double` and `char`

You can also define your own Java methods `toDouble` and `toChar` to change the output of the MATLAB `double` and `char` functions. For more information, see the sections entitled “Converting to the MATLAB double Data Type” and “Converting to the MATLAB char Data Type” on page 7-64.

How MATLAB Handles Undefined Methods

If your MATLAB command invokes a nonexistent method on a Java object, MATLAB looks for a built-in function with the same name. If MATLAB finds a built-in function of that name, it attempts to invoke it. If MATLAB does not find a function with that name, it displays a message stating that it cannot find a method by that name for the class.

For example, MATLAB has a built-in method named `size`, and the Java API `java.awt.Frame` class also has a `size` method. If you call `size` on a `Frame` object, the `size` method defined by `java.awt.Frame` is executed. However, if you call `size` on an object of `java.lang.String`, MATLAB does not find a `size` method for this class. It executes the MATLAB `size` built-in instead.

```
string = java.lang.String('hello');

size(string)
ans =
     1     1
```

Note When you define a Java class for use in MATLAB, avoid giving any of its methods the same name as a MATLAB built-in function.

How MATLAB Handles Java Exceptions

If invoking a Java method or constructor throws an exception, MATLAB catches the exception and transforms it into a MATLAB error. MATLAB puts the text of the Java error message into its own error message. Receiving an error from a Java method or constructor has the same appearance as receiving an error from an M-file.

Working with Java Arrays

You can pass singular Java objects to and from methods or you may pass them in an array, providing the method expects them in that form. This array must either be a Java array (returned from another method call or created within MATLAB) or, under certain circumstances, a MATLAB cell array. This section describes how to create and manipulate Java arrays in MATLAB. Later sections will describe how to use MATLAB cell arrays in calls to Java methods.

Note The term *dimension* here refers more to the number of subscripts required to address the elements of an array than to its length, width, and height characteristics. For example, a 5-by-1 array is referred to as being one-dimensional, as its individual elements can be indexed into using only one array subscript.

This section addresses the following topics:

- “How MATLAB Represents the Java Array”
- “Creating an Array of Objects Within MATLAB”
- “Accessing Elements of a Java Array”
- “Assigning to a Java Array”
- “Concatenating Java Arrays”
- “Creating a New Array Reference”
- “Creating a Copy of a Java Array”

How MATLAB Represents the Java Array

The term *java array* refers to any array of Java objects returned from a call to a Java class constructor or method. You may also construct a Java array within MATLAB using the `javaArray` function. The structure of a Java array is significantly different from that of a MATLAB matrix or array. MATLAB *hides* these differences whenever possible, allowing you to operate on the arrays using the usual MATLAB command syntax. Just the same, it may be helpful to keep the following differences in mind as you work with Java arrays.

Representing More Than One Dimension

An array in the Java language is strictly a one-dimensional structure because it is measured only in length. If you want to work with a two-dimensional array, you can create an equivalent structure using an array of arrays. To add further dimensions, you add more levels to the array, making it an array of arrays of arrays, and so on. You may want to use such multilevel arrays when working in MATLAB as it is a matrix and array-based programming language.

MATLAB makes it easy for you to work with multilevel Java arrays by treating them like the matrices and multidimensional arrays that are a part of the language itself. You access elements of an array of arrays using the same MATLAB syntax that you would use if you were handling a matrix. If you were to add more levels to the array, MATLAB would be able to access and operate on the structure as if it were a multidimensional MATLAB array.

The left side of the following figure shows Java arrays of one, two, and three dimensions. To the right of each is the way the same array is represented to you in MATLAB. Note that single-dimension arrays are represented as a column vector.

Array Access from Java

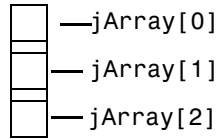

Simple Array

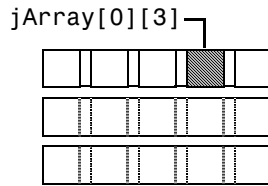

Array of Arrays

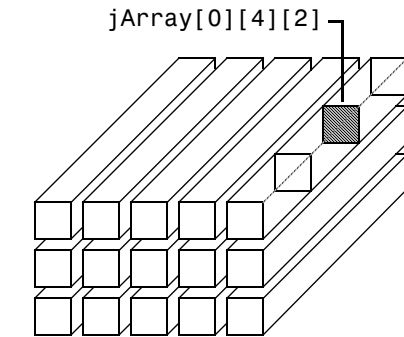

Array of Arrays of Arrays

Array Access from MATLAB

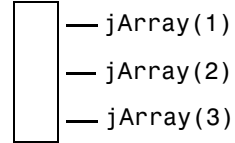

One-dimensional Array

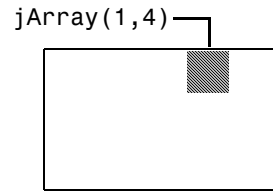

Two-Dimensional Array

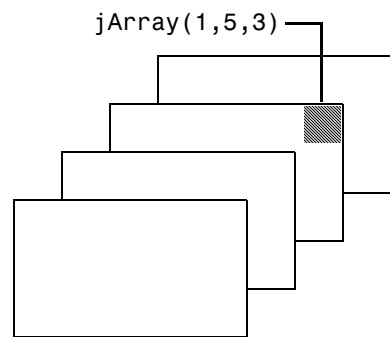

Three-Dimensional Array



Array Indexing

Java array indexing is different than MATLAB array indexing. Java array indices are zero-based, MATLAB array indices are one-based. In Java programming, you access the elements of array y of length N using $y[0]$ through $y[N-1]$. When working with this array in MATLAB, you access these same elements using the MATLAB indexing style of $y(1)$ through $y(N)$. Thus, if you have a Java array of 10 elements, the seventh element is obtained using $y(7)$, and not $y[6]$ as you would have used when writing a program in Java.

The Shape of the Java Array

A Java array can be different from a MATLAB array in its overall *shape*. A two-dimensional MATLAB array maintains a rectangular shape, as each row is of equal length and each column of equal height. The Java counterpart of this, an array of arrays, does not necessarily hold to this rectangular form. Each individual lower level array may have a different length.

Such an array structure is pictured below. This is an array of three underlying arrays of different lengths. The term *ragged* is commonly used to describe this arrangement of array elements as the array ends do not match up evenly. When a Java method returns an array with this type of structure, it is stored in a cell array by MATLAB.

jArray[0]		length = 5
jArray[1]		length = 2
jArray[2]		length = 3

Interpreting the Size of a Java Array

When the MATLAB `size` function is applied to a simple Java array, the number of rows returned is the length of the Java array and the number of columns is always 1.

Determining the size of a Java array of arrays is not so simple. The potentially ragged shape of an array returned from Java makes it impossible to size the array in the same way as for a rectangular matrix. In a ragged Java array, there is no one value that represents the size of the lower level arrays.

When the `size` function is applied to a Java array of arrays, the resulting value describes the top level of the specified array. For the Java array shown here

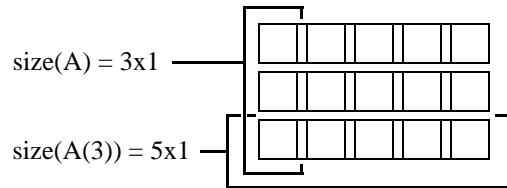

`size(A)` returns the dimensions of the highest array level of `A`. The highest level of the array has a size of 3-by-1.

```
size(A)
ans =
     3     1
```

To find the size of a lower level array, say the five-element array in row 3, refer to the row explicitly.

```
size(A(3))
ans =
     5     1
```

You can specify a dimension in the `size` command using the following syntax. However, you will probably find this useful only for sizing the first dimension, `dim=1`, as this will be the only non-unary dimension.

```
m = size(X,dim)

size(A, 1)
ans =
     3
```

Interpreting the Number of Dimensions of a Java Arrays

For Java arrays, whether they are simple one-level arrays or multilevel, the MATLAB `ndims` function always returns a value of 2 to indicate the number of dimensions in the array. This is a measure of the number of dimensions in the top-level array which will always be equal to 2.

Creating an Array of Objects Within MATLAB

To call a Java method that has one or more arguments defined as an array of Java objects, you must, under most circumstances, pass your objects in a Java array. You can construct an array of objects in a call to a Java method or constructor. Or you can create the array within MATLAB.

The MATLAB `javaArray` function lets you create a Java array structure that can be handled in MATLAB as a single multidimensional array. You specify the number and size of the array dimensions along with the class of objects you intend to store in it. Using the one-dimensional Java array as its primary building block, MATLAB then builds an array structure that satisfies the dimensions requested in the `javaArray` command.

Using the `javaArray` Function

To create a Java object array, use the MATLAB `javaArray` function, which has the following syntax.

```
A = javaArray('element_class', m, n, p, ...)
```

The first argument is the `'element_class'` string, which names the class of the elements in the array. You must specify the fully qualified name (package and class name). The remaining arguments (`m`, `n`, `p`, ...) are the number of elements in each dimension of the array.

An array that you create with `javaArray` is equivalent to the array that you would create with the Java code.

```
A = new element_class[m][n][p]...;
```

The following command builds a Java array of four lower level arrays, each capable of holding five objects of the `java.lang.Double` class. (You will probably be more likely to use primitive types of double than instances of the `java.lang.Double` class, but in this context, it affords us a simple example.)

```
dblArray = javaArray('java.lang.Double', 4, 5);
```

The `javaArray` function does not deposit any values into the array elements that it creates. You must do this separately. The following MATLAB code stores objects of the `java.lang.Double` type in the Java array `dblArray` that was just created.

```
for m = 1:4
    for n = 1:5
        dblArray(m,n) = java.lang.Double((m*10) + n);
    end
end

dblArray
dblArray =
java.lang.Double[][]:
    [11]    [12]    [13]    [14]    [15]
    [21]    [22]    [23]    [24]    [25]
    [31]    [32]    [33]    [34]    [35]
    [41]    [42]    [43]    [44]    [45]
```

Another Way to Create a Java Array

You can also create an array of Java objects using syntax that is more typical to MATLAB. For example, the following syntax creates a 4-by-5 MATLAB array of type double and assigns zero to each element of the array.

```
matlabArray(4,5) = 0;
```

You use similar syntax to create a Java array in MATLAB, except that you must specify the Java class name. The value being assigned, 0 in this example, is stored in the final element of the array, `javaArray(4,5)`. All other elements of the array receive the empty matrix.

```
javaArray(4,5) = java.lang.Double(0)
javaArray =
java.lang.Double[][]:
    []    []    []    []    []
    []    []    []    []    []
    []    []    []    []    []
    []    []    []    []    [0]
```

Note You cannot change the dimensions of an existing Java array as you can with a MATLAB array. The same restriction exists when working with Java arrays in the Java language. See the example below.

This example first creates a scalar MATLAB array, and then successfully modifies it to be two-dimensional.

```
matlabArray = 0;
matlabArray(4,5) = 0

matlabArray =

     0     0     0     0     0
     0     0     0     0     0
     0     0     0     0     0
     0     0     0     0     0
```

When you try this with a Java array, you get an error. Similarly, you cannot create an array of Java arrays from a Java array, and so forth.

```
javaArray = java.lang.Double(0);
javaArray(4,5) = java.lang.Double(0);
??? Index exceeds Java array dimensions.
```

Accessing Elements of a Java Array

You can access elements of a Java object array by using the MATLAB array indexing syntax, `A(row,col)`. For example, to access the element of array `dblArray` located at row 3, column 4, use

```
row3_col4 = dblArray(3,4)
row3_col4 =
34.0
```

In Java, this would be `dblArray[2][3]`.

You can also use MATLAB array indexing syntax to access an element in an object's data field. Suppose that `myMenuObj` is an instance of a window menu class. This user-supplied class has a data field, `menuItemArray`, which is a Java array of `java.awt.menuItem`. To get element 3 of this array, use the following command.

```
currentItem = myMenuObj.menuItemArray(3)
```

Using Single Subscript Indexing to Access Arrays

Elements of a MATLAB matrix are most commonly referenced using both row and column subscripts. For example, you use `x(3,4)` to reference the array

element at the intersection of row 3 and column 4. Sometimes it is more advantageous to use just a single subscript. MATLAB provides this capability (see the section on “Linear Indexing” in the *Using MATLAB* manual).

Indexing into a MATLAB matrix using a single subscript references one element of the matrix. Using the MATLAB matrix shown here, `matlabArray(3)` returns a single element of the matrix.

```
matlabArray = [11 12 13 14 15; 21 22 23 24 25; ...
               31 32 33 34 35; 41 42 43 44 45]
matlabArray =
    11    12    13    14    15
    21    22    23    24    25
    31    32    33    34    35
    41    42    43    44    45

matlabArray(3)
ans =
    31
```

Indexing this way into a Java array of arrays references an entire subarray of the overall structure. Using the `dblArray` Java array, that looks the same as `matlabArray` shown above, `dblArray(3)` returns the 5-by-1 array that makes up the entire third row.

```
row3 = dblArray(3)
row3 =
java.lang.Double[]:
 [31]
 [32]
 [33]
 [34]
 [35]
```

This is a useful feature of MATLAB as it allows you to specify an entire array from a larger array structure, and then manipulate it as an object.

Using the Colon Operator

Use of the MATLAB colon operator (`:`) is supported in subscripting Java array references. This operator works just the same as when referencing the contents of a MATLAB array. Using the Java array of `java.lang.Double` objects shown

here, the statement `dblArray(2,2:4)` refers to a portion of the lower level array, `dblArray(2)`. A new array, `row2Array`, is created from the elements in columns 2 through 4.

```
dblArray
dblArray =
java.lang.Double[][]:
    [11]    [12]    [13]    [14]    [15]
    [21]    [22]    [23]    [24]    [25]
    [31]    [32]    [33]    [34]    [35]
    [41]    [42]    [43]    [44]    [45]

row2Array = dblArray(2,2:4)
row2Array =
java.lang.Double[]:
    [22]
    [23]
    [24]
```

You also can use the colon operator in single-subscript indexing, as covered in “Using Single Subscript Indexing to Access Arrays” on page 7-41. By making your subscript a colon rather than a number, you can convert an array of arrays into one linear array. The following example converts the 4-by-5 array `dblArray` into a 20-by-1 linear array.

```
linearArray = dblArray(:)
linearArray =
java.lang.Double[]:
    [11]
    [12]
    [13]
    [14]
    [15]
    [21]
    [22]
    .
    .
    .
```

This works the same way on an N-dimensional Java array structure. Using the colon operator as a single subscripted index into the array produces a linear array composed of all of the elements of the original array.

Note Java and MATLAB arrays are stored differently in memory. This is reflected in the order they are given in a linear array. Java array elements are stored in an order that matches the *rows* of the matrix, (11, 12, 13, . . . in the array shown above). MATLAB array elements are stored in an order that matches the *columns*, (11, 21, 31, . . .).

Using END in a Subscript

You can use the end keyword in the first subscript of an access statement. The first subscript references the top-level array in a multilevel Java array structure.

Note Using end on lower level arrays is not valid due to the potentially ragged nature of these arrays (see “The Shape of the Java Array” on page 7-37). In this case, there is no consistent end value to be derived.

The following example displays data from the third to the last row of Java array dblArray.

```
last2rows = dblArray(3:end, :)
last2rows =
java.lang.Double[][]:
    [31]    [32]    [33]    [34]    [35]
    [41]    [42]    [43]    [44]    [45]
```

Assigning to a Java Array

You assign values to objects in a Java array in essentially the same way as you do in a MATLAB array. Although Java and MATLAB arrays are structured quite differently, you use the same command syntax to specify which elements you want to assign to. See “How MATLAB Represents the Java Array” on page 7-35 for more information on Java and MATLAB array differences.

The following example deposits the value 300 in the `dblArray` element at row 3, column 2. In Java, this would be `dblArray[2][1]`.

```
dblArray(3,2) = java.lang.Double(300)
dblArray =
java.lang.Double[][]:
  [11]    [ 12]    [13]    [14]    [15]
  [21]    [ 22]    [23]    [24]    [25]
  [31]    [300]    [33]    [34]    [35]
  [41]    [ 42]    [43]    [44]    [45]
```

You use the same syntax to assign to an element in an object's data field. Continuing with the `myMenuObj` example shown in "Accessing Elements of a Java Array" on page 7-41, you assign to the third menu item in `menuItemArray` as follows.

```
myMenuObj.menuItemArray(3) = java.lang.String('Save As...');
```

Using Single Subscript Indexing for Array Assignment

You can use a single-array subscript to index into a Java array structure that has more than one dimension. Refer to "Using Single Subscript Indexing to Access Arrays" on page 7-41 for a description of this feature as used with Java arrays.

You can use single-subscript indexing to assign values to an array as well. The example below assigns a one-dimensional Java array, `onedimArray`, to a row of a two-dimensional Java array, `dblArray`. Start out by creating the one-dimensional array.

```
onedimArray = javaArray('java.lang.Double', 5);
for k = 1:5
    onedimArray(k) = java.lang.Double(100 * k);
end
```

Since `dblArray(3)` refers to the 5-by-1 array displayed in the third row of `dblArray`, you can assign the entire, similarly dimensioned, 5-by-1 `onedimArray` to it.

```
dblArray(3) = onedimArray
dblArray =
java.lang.Double[][]:
    [ 11]    [ 12]    [ 13]    [ 14]    [ 15]
    [ 21]    [ 22]    [ 23]    [ 24]    [ 25]
    [100]    [200]    [300]    [400]    [500]
    [ 41]    [ 42]    [ 43]    [ 44]    [ 45]
```

Assigning to a Linear Array

You can assign a value to *every* element of a multidimensional Java array by treating the array structure as if it were a single linear array. This entails replacing the single, numerical subscript with the MATLAB colon operator. If you start with the `dblArray` array, you can initialize the contents of every object in the two-dimensional array with the following statement.

```
dblArray(:) = java.lang.Double(0)
dblArray =
java.lang.Double[][]:
    [0]    [0]    [0]    [0]    [0]
    [0]    [0]    [0]    [0]    [0]
    [0]    [0]    [0]    [0]    [0]
    [0]    [0]    [0]    [0]    [0]
```

Using the Colon Operator

You can use the MATLAB colon operator as you would when working with MATLAB arrays. The statements below assign given values to each of the four rows in the Java array, `dblArray`. Remember that each row actually represents a separate Java array in itself.

```
dblArray(1,:) = java.lang.Double(125);
dblArray(2,:) = java.lang.Double(250);
dblArray(3,:) = java.lang.Double(375);
dblArray(4,:) = java.lang.Double(500)
dblArray =
java.lang.Double[][]:
    [125]    [125]    [125]    [125]    [125]
    [250]    [250]    [250]    [250]    [250]
    [375]    [375]    [375]    [375]    [375]
    [500]    [500]    [500]    [500]    [500]
```

Assigning the Empty Matrix

When working with MATLAB arrays, you can assign the empty matrix, (i.e., the 0-by-0 array denoted by `[]`) to an element of the array. For Java arrays, you can also assign `[]` to array elements. This stores the NULL value, rather than a 0-by-0 array, in the Java array element.

Subscripted Deletion

When you assign the empty matrix value to an entire row or column of a MATLAB array, you find that MATLAB actually removes the affected row or column from the array. In the example below, the empty matrix is assigned to all elements of the fourth column in the MATLAB matrix, `matlabArray`. Thus, the fourth column is completely eliminated from the matrix. This changes its dimensions from 4-by-5 to 4-by-4.

```
matlabArray = [11 12 13 14 15; 21 22 23 24 25; ...
              31 32 33 34 35; 41 42 43 44 45]
```

```
matlabArray =
    11    12    13    14    15
    21    22    23    24    25
    31    32    33    34    35
    41    42    43    44    45
```

```
matlabArray(:,4) = []
```

```
matlabArray =
    11    12    13    15
    21    22    23    25
    31    32    33    35
    41    42    43    45
```

You can assign the empty matrix to a Java array, but the effect will be different. The next example shows that, when the same operation is performed on a Java array, the structure is not collapsed; it maintains its 4-by-5 dimensions.

```
dblArray(:,4) = []
dblArray =
java.lang.Double[][]:
    [125]    [125]    [125]    []    [125]
    [250]    [250]    [250]    []    [250]
    [375]    [375]    [375]    []    [375]
    [500]    [500]    [500]    []    [500]
```

The `dblArray` data structure is actually an array of five-element arrays of `java.lang.Double` objects. The empty array assignment placed the `NULL` value in the fourth element of each of the lower level arrays.

Concatenating Java Arrays

You can concatenate arrays of Java objects in the same way as arrays of other data types. (To understand how scalar Java objects are concatenated by MATLAB see “Concatenating Java Objects” on page 7-17.)

Use either the `cat` function or the square bracket (`[]`) operators. This example horizontally concatenates two Java arrays: `d1`, and `d2`.

```
% Construct a 2-by-3 array of java.lang.Double.
d1 = javaArray('java.lang.Double',2,3);
for m = 1:3    for n = 1:3
d1(m,n) = java.lang.Double(n*2 + m-1);
end;          end;

d1
d1 =
java.lang.Double[][]:
    [2]    [4]    [6]
    [3]    [5]    [7]
    [4]    [6]    [8]

% Construct a 2-by-2 array of java.lang.Double.
d2 = javaArray('java.lang.Double',2,2);
for m = 1:3    for n = 1:2
d2(m,n) = java.lang.Double((n+3)*2 + m-1);
end;          end;
```

```

d2
d2 =
java.lang.Double[][]:
    [ 8]    [10]
    [ 9]    [11]
    [10]    [12]

% Concatenate the two along the second dimension.
d3 = cat(2,d1,d2)
d3 =
java.lang.Double[][]:
    [2]    [4]    [6]    [ 8]    [10]
    [3]    [5]    [7]    [ 9]    [11]
    [4]    [6]    [8]    [10]    [12]

```

Creating a New Array Reference

Because Java arrays in MATLAB are *references*, assigning an array variable to another variable results in a second reference to the array.

Consider the following example where two separate array variables reference a common array. The original array, `origArray`, is created and initialized. The statement `newArrayRef = origArray` creates a copy of this array variable. Changes made to the array referred to by `newArrayRef` also show up in the original array.

```

origArray = javaArray('java.lang.Double', 3, 4);
for m = 1:3
    for n = 1:4
        origArray(m,n) = java.lang.Double((m * 10) + n);
    end
end

origArray
origArray =
java.lang.Double[][]:
    [11]    [12]    [13]    [14]
    [21]    [22]    [23]    [24]
    [31]    [32]    [33]    [34]

```

```
% ----- Make a copy of the array reference -----
newArrayRef = origArray;
newArrayRef(3,:) = java.lang.Double(0);

origArray
origArray =
java.lang.Double[][]:
    [11]    [12]    [13]    [14]
    [21]    [22]    [23]    [24]
    [ 0]    [ 0]    [ 0]    [ 0]
```

Creating a Copy of a Java Array

You can create an entirely new array from an existing Java array by indexing into the array to describe a block of elements, (or subarray), and assigning this subarray to a variable. The assignment copies the values in the original array to the corresponding cells of the new array.

As with the example in section “Creating a New Array Reference” on page 7-49, an original array is created and initialized. But, this time, a copy is made of the array contents rather than copying the array reference. Changes made using the reference to the new array do not affect the original.

```
origArray = javaArray('java.lang.Double', 3, 4);
for m = 1:3
    for n = 1:4
        origArray(m,n) = java.lang.Double((m * 10) + n);
    end
end

origArray
origArray =
java.lang.Double[][]:
    [11]    [12]    [13]    [14]
    [21]    [22]    [23]    [24]
    [31]    [32]    [33]    [34]
```



```
% ----- Make a copy of the array contents -----
newArray = origArray(:,:);
newArray(3,:) = java.lang.Double(0);

origArray
origArray =
java.lang.Double[][]:
    [11]    [12]    [13]    [14]
    [21]    [22]    [23]    [24]
    [31]    [32]    [33]    [34]
```

Passing Data to a Java Method

When you make a call from MATLAB to Java code, any MATLAB data types you pass in the call are converted to data types native to the Java language. MATLAB performs this conversion on each argument that is passed, except for those arguments that are already Java objects. This section describes the conversion that is performed on specific MATLAB data types and, at the end, also takes a look at how argument types affect calls made to overloaded methods.

If data is to be returned by the method being called, MATLAB receives this data and converts it to the appropriate MATLAB format wherever necessary. This process is covered in the next section entitled “Handling Data Returned from a Java Method” on page 7-62.

This section addresses the following topics:

- “Conversion of MATLAB Argument Data”
- “Passing Built-In Data Types”
- “Passing String Arguments”
- “Passing Java Objects”
- “Other Data Conversion Topics”
- “Passing Data to Overloaded Methods”

Conversion of MATLAB Argument Data

MATLAB data, passed as arguments to Java methods, are converted by MATLAB into data types that best represent the data to the Java language. The table below shows all of the MATLAB base types for passed arguments and the Java base types defined for input arguments. Each row shows a MATLAB type followed by the possible Java argument matches, from left to right in order of closeness of the match. The MATLAB types (except cell arrays) can all be

scalar (1-by-1) arrays or matrices. All of the Java types can be scalar values or arrays.

Table 7-2: Conversion of MATLAB Types to Java Types

MATLAB Argument	Closest Type (7)	Java Input Argument (Scalar or Array)					Least Close Type (1)
double (logical)	boolean	byte	short	int	long	float	double
double	double	float	long	int	short	byte	boolean
single	float	double	N/A	N/A	N/A	N/A	N/A
char	String	char	N/A	N/A	N/A	N/A	N/A
uint8	byte	short	int	long	float	double	
uint16	short	int	long	float	double	N/A	N/A
uint32	int	long	float	double		N/A	N/A
int8	byte	short	int	long	float	double	N/A
int16	short	int	long	float	double	N/A	N/A
int32	int	long	float	double	N/A	N/A	N/A
cell array of strings	array of String	N/A	N/A	N/A	N/A	N/A	N/A
Java object	Object	N/A	N/A	N/A	N/A	N/A	N/A
cell array of object	array of Object	N/A	N/A	N/A	N/A	N/A	N/A

Data type conversion of arguments passed to Java code will be discussed in the following three categories. MATLAB handles each category differently.

- “Passing Built-In Data Types”
- “Passing String Arguments”
- “Passing Java Objects”

Passing Built-In Data Types

Java has eight data types that are intrinsic to the language and are not represented as Java objects. These are often referred to as *built-in*, or *elemental*, data types and they include boolean, byte, short, long, int, double, float, and char. MATLAB converts its own data types to these Java built-in types according to the table, “Conversion of MATLAB Types to Java Types” on page 7-53. Built-in types are in the first 10 rows of the table.

When a Java method you are calling expects one of these data types, you can pass it the type of MATLAB argument shown in the left-most column of the table. If the method takes an array of one of these types, you can pass a MATLAB array of the data type. MATLAB converts the data type of the argument to the type assigned in the method declaration.

The MATLAB code shown below creates a top-level window frame and sets its dimensions. The call to `setBounds` passes four MATLAB scalars of the double type to the inherited Java Frame method, `setBounds`, that takes four arguments of the int type. MATLAB converts each 64-bit double data type to a 32-bit integer prior to making the call. Shown here is the `setBounds` method declaration followed by the MATLAB code that calls the method.

```
public void setBounds(int x, int y, int width, int height)

frame=java.awt.Frame;
frame.setBounds(200,200,800,400);
frame.setVisible(1);
```

Passing Built-In Types in an Array

To call a Java method with an argument defined as an *array* of a built-in type, you can create and pass a MATLAB matrix with a compatible base type. The following code defines a polygon by sending four x and y coordinates to the Polygon constructor. Two 1-by-4 MATLAB arrays of double are passed to `java.awt.Polygon`, which expects integer arrays in the first two arguments. Shown here is the Java method declaration followed by MATLAB code that calls the method, and then verifies the set coordinates.

```
public Polygon(int xpoints[], int ypoints[], int npoints)

poly = java.awt.Polygon([14 42 98 124], [55 12 -2 62], 4);
```

```
[poly.xpoints poly.ypoints]      % Verify the coordinates
ans =
    14     55
    42     12
    98    -2
   124     62
```

MATLAB Arrays Are Passed by Value

Since MATLAB arrays are passed by value, any changes that a Java method makes to them will not be visible to your MATLAB code. If you need to access changes that a Java method makes to an array, then, rather than passing a MATLAB array, you should create and pass a Java array, which is a reference. For a description of using Java arrays in MATLAB, see “Working with Java Arrays” on page 7-34.

Note Generally, it is preferable to have methods return data that has been modified using the return argument mechanism as opposed to passing a reference to that data in an argument list.

Passing String Arguments

To call a Java method that has an argument defined as an object of class `java.lang.String`, you can pass either a `String` object that was returned from an earlier Java call or a MATLAB 1-by-n character array. If you pass the character array, MATLAB converts the array to a Java object of `java.lang.String` for you.

For a programming example, see “Example – Reading a URL” on page 7-69. This shows a MATLAB character array that holds a URL being passed to the Java URL class constructor. The constructor, shown below, expects a Java `String` argument.

```
public URL(String spec) throws MalformedURLException
```

In the MATLAB call to this constructor, a character array specifying the URL is passed. MATLAB converts this array to a Java String object prior to calling the constructor.

```
url = java.net.URL(...
    'http://archive.ncsa.uiuc.edu/demoweb/')
```

Passing Strings in an Array

When the method you are calling expects an argument of an array of type String, you can create such an array by packaging the strings together in a MATLAB cell array. The strings can be of varying lengths since you are storing them in different cells of the array. As part of the method call, MATLAB converts the cell array to a Java array of String objects.

In the following example, the echoPrompts method of a user-written class accepts a string array argument that MATLAB converted from its original format as a cell array of strings. The parameter list in the Java method appears as follows.

```
public String[] echoPrompts(String s[])
```

You create the input argument by storing both strings in a MATLAB cell array. MATLAB converts this structure to a Java array of String.

```
myaccount.echoPrompts({'Username: ', 'Password: '})
ans =
'Username: '
'Password: '
```

Passing Java Objects

When calling a method that has an argument belonging to a particular Java class, you must pass an object that is an instance of that class. In the example below, the add method belonging to the java.awt.Menu class requires, as an argument, an object of the java.awt.MenuItem class. The method declaration for this is

```
public MenuItem add(MenuItem mi)
```

The example operates on the frame created in the previous example in “Passing Built-In Data Types” on page 7-54. The second, third, and fourth lines of code shown here add items to a menu to be attached to the existing window frame.

In each of these calls to `menu1.add`, an object that is an instance of the `java.awt.MenuItem` Java class is passed.

```

menu1 = java.awt.Menu('File Options');
menu1.add(java.awt.MenuItem('New'));
menu1.add(java.awt.MenuItem('Open'));
menu1.add(java.awt.MenuItem('Save'));

menuBar=java.awt.MenuBar;
menuBar.add(menu1);
frame.setMenuBar(menuBar);

```

Handling Objects of Class `java.lang.Object`

A special case exists when the method being called takes an argument of the `java.lang.Object` class. Since this class is the root of the Java class hierarchy, you can pass objects of any class in the argument. The hash table example shown that follows, passes objects belonging to different classes to a common method, `put`, which expects an argument of `java.lang.Object`. The method declaration for `put` is

```
public synchronized Object put(Object key, Object value)
```

The following MATLAB code passes objects of different types (boolean, float, and string) to the `put` method.

```

hTable = java.util.Hashtable;
hTable.put(0, java.lang.Boolean('TRUE'));
hTable.put(1, java.lang.Float(41.287));
hTable.put(2, java.lang.String('test string'));

hTable          % Verify hash table contents
hTable =
{1.0=41.287, 2.0=test string, 0.0=true}

```

When passing arguments to a method that takes `java.lang.Object`, it is not necessary to specify the class name for objects of a built-in data type. Line three, in the example above, specifies that `41.287` is an instance of class `java.lang.Float`. You can omit this and simply say, `41.287`, as shown in the following example. Thus, MATLAB will create each object for you, choosing the closest matching Java object representation for each argument.

The three calls to put from the preceding example can be rewritten as

```
hTable.put(0, 1);  
hTable.put(1, 41.287);  
hTable.put(2, 'test string');
```

Passing Objects in an Array

The only types of Java object arrays that you can pass to Java methods are Java arrays and MATLAB cell arrays.

If the objects have already been placed into an array, either an array returned from a Java constructor or constructed in MATLAB by the `javaArray` function, then you simply pass it as is in the argument to the method being called. No conversion is done by MATLAB, as this is already a Java array.

If you have objects that are not already in a Java array, then MATLAB allows you to simply pass them in a MATLAB cell array. In this case, MATLAB converts the cell array to a Java array prior to passing the argument.

The following example shows the `mapPoints` method of a user-written class accepting an array of class `java.awt.Point`. The method declaration for this is

```
public Object mapPoints(java.awt.Point p[])
```

The MATLAB code shown below creates a 2-by-2 cell array containing four Java Point objects. When the cell array is passed to the `mapPoints` method, MATLAB converts it to a Java array of type `java.awt.Point`.

```
pointObj1 = java.awt.Point(25,143);  
pointObj2 = java.awt.Point(31,147);  
pointObj3 = java.awt.Point(49,151);  
pointObj4 = java.awt.Point(52,176);  
  
cellArray={pointObj1, pointObj2; pointObj3, pointObj4}  
cellArray =  
    [1x1 java.awt.Point]    [1x1 java.awt.Point]  
    [1x1 java.awt.Point]    [1x1 java.awt.Point]  
  
testData.mapPoints(cellArray);
```

Handling a Cell Array of Java Objects

You create a cell array of Java objects by using the MATLAB syntax `{a1, a2, ...}`. You index into a cell array of Java objects in the usual way, with the syntax `a{m, n, ...}`.

The following example creates a cell array of two `Frame` objects, `frame1` and `frame2`, and assigns it to variable `frames`.

```
frame1 = java.awt.Frame('Frame A');
frame2 = java.awt.Frame('Frame B');

frameArray = {frame1, frame2}
frameArray =
 [1x1 java.awt.Frame]    [1x1 java.awt.Frame]
```

The next statement assigns element `{1,2}` of the cell array `frameArray` to variable `f`.

```
f = frameArray {1,2}
f =
 java.awt.Frame[frame2,0,0,0x0,invalid,hidden,layout =
 java.awt.BorderLayout,resizable,title=Frame B]
```

Other Data Conversion Topics

There are several remaining items of interest regarding the way MATLAB converts its data to a compatible Java type. This includes how MATLAB matches array dimensions, and how it handles empty matrices and empty strings.

How Array Dimensions Affect Conversion

The term *dimension*, as used in this section, refers more to the number of subscripts required to address the elements of an array than to its length, width, and height characteristics. For example, a 5-by-1 array is referred to as having one dimension, as its individual elements can be indexed into using only one array subscript.

In converting MATLAB to Java arrays, MATLAB handles dimension in a special manner. For a MATLAB array, dimension can be considered as the number of nonsingleton dimensions in the array. For example, a 10-by-1 array has dimension 1, and a 1-by-1 array has dimension 0. In Java, dimension is

determined solely by the number of nested arrays. For example, `double[][]` has dimension 2, and `double` has dimension 0.

If the Java array's number of dimensions exactly matches the MATLAB array's number of dimensions n , then the conversion results in a Java array with n dimensions. If the Java array has fewer than n dimensions, the conversion drops singleton dimensions, starting with the first one, until the number of remaining dimensions matches the number of dimensions in the Java array.

Empty Matrices and Nulls

The empty matrix is compatible with any method argument for which NULL is a legal value in Java. The empty string (' ') in MATLAB translates into an empty (not NULL) String object in Java.

Passing Data to Overloaded Methods

When you invoke an overloaded method on a Java object, MATLAB determines which method to invoke by comparing the arguments your call passes to the arguments defined for the methods. Note that in this discussion, the term *method* includes constructors. When it determines the method to call, MATLAB converts the calling arguments to Java method types according to Java conversion rules, except for conversions involving objects or cell arrays. See "Passing Objects in an Array" on page 7-58.

How MATLAB Determines the Method to Call

When your MATLAB function calls a Java method, MATLAB:

- 1 Checks to make sure that the object (or class, for a static method) has a method by that name
- 2 Determines whether the invocation passes the same number of arguments of at least one method with that name
- 3 Makes sure that each passed argument can be converted to the Java type defined for the method

If all of the preceding conditions are satisfied, MATLAB calls the method.

In a call to an overloaded method, if there is more than one candidate, MATLAB selects the one with arguments that best fit the calling arguments.

First, MATLAB rejects all methods that have any argument types that are incompatible with the passed arguments (for example, if the method has a double argument and the passed argument is a char).

Among the remaining methods, MATLAB selects the one with the highest fitness value, which is the sum of the fitness values of all its arguments. The fitness value for each argument is the fitness of the base type minus the difference between the MATLAB array dimension and the Java array dimension. (Array dimensionality is explained in “How Array Dimensions Affect Conversion” on page 7-59.) If two methods have the same fitness, the first one defined in the Java class is chosen.

Example - Calling an Overloaded Method

Suppose a function constructs a `java.io.OutputStreamWriter` object, `osw`, and then invokes a method on the object.

```
osw.write('Test data', 0, 9);
```

MATLAB finds that the class `java.io.OutputStreamWriter` defines three `write` methods.

```
public void write(int c);
public void write(char[] cbuf, int off, int len);
public void write(String str, int off, int len);
```

MATLAB rejects the first `write` method, because it takes only one argument. Then, MATLAB assesses the fitness of the remaining two `write` methods. These differ only in their first argument, as explained below.

In the first of these two `write` methods, the first argument is defined with base type, `char`. The table, Conversion of MATLAB Types to Java Types, shows that for the type of the calling argument (MATLAB `char`), Java type, `char`, has a value of 6. There is no difference between the dimension of the calling argument and the Java argument. So the fitness value for the first argument is 6.

In the other `write` method, the first argument has Java type `String`, which has a fitness value of 7. The dimension of the Java argument is 0, so the difference between it and the calling argument dimension is 1. Therefore, the fitness value for the first argument is 6.

Because the fitness value of those two `write` methods is equal, MATLAB calls the one listed first in the class definition, with `char[]` first argument.

Handling Data Returned from a Java Method

In many cases, data returned from Java is incompatible with the data types operated on within MATLAB. When this is the case, MATLAB converts the returned value to a data type native to the MATLAB language. This section describes the conversion performed on the various data types that can be returned from a call to a Java method.

This section addresses the following topics:

- “Conversion of Java Return Data”
- “Built-In Data Types”
- “Java Objects”
- “Converting Objects to MATLAB Data Types”

Conversion of Java Return Data

The following table lists Java return types and the resulting MATLAB types. For some Java base return types, MATLAB treats scalar and array returns differently, as described following the table.

Table 7-3: Conversion of Java Types to MATLAB Types

Java Return Type	If Scalar Return, Resulting MATLAB Type	If Array Return, Resulting MATLAB Type
boolean	double (logical)	double (logical)
byte	double	int8
short	double	int16
int	double	int32
long	double	double
float	double	single
double	double	double
char	char	char

Built-In Data Types

Java *built-in* data types are described in “Passing Built-In Data Types” on page 7-54. Basically, this data type includes `boolean`, `byte`, `short`, `long`, `int`, `double`, `float`, and `char`. When the value returned from a method call is one of these Java built-in types, MATLAB converts it according to the table, “Conversion of Java Types to MATLAB Types” on page 7-62.

A single numeric or boolean value converts to a 1-by-1 matrix of `double`, which is convenient for use in MATLAB. An array of a numeric or boolean return values converts to an array of the closest base type, to minimize the required storage space. Array conversions are listed in the right-hand column of the table.

A return value of Java type `char` converts to a 1-by-1 matrix of `char`. And an array of Java `char` converts to a MATLAB array of that type.

Java Objects

When a method call returns Java objects, MATLAB leaves them in their original form. They remain as Java objects so you can continue to use them to interact with other Java methods.

The only exception to this is when the method returns data of type, `java.lang.Object`. This class is the root of the Java class hierarchy and is frequently used as a catchall for objects and arrays of various types. When the method being called returns a value of the `Object` class, MATLAB converts its value according to the table, “Conversion of Java Types to MATLAB Types” on page 7-62. That is, numeric and boolean objects such as `java.lang.Integer` or `java.lang.Boolean` convert to a 1-by-1 MATLAB matrix of `double`. Object arrays of these types convert to the MATLAB data types listed in the right-hand column of the table. Other object types are not converted.

Converting Objects to MATLAB Data Types

With the exception of objects of class `String` and class `Object`, MATLAB does not convert Java objects returned from method calls to a native MATLAB data type. If you want to convert Java object data to a form more readily usable in MATLAB, there are a few MATLAB functions that enable you to do this. These are described in the following sections.

Converting to the MATLAB double Data Type

Using the `double` function in MATLAB, you can convert any Java object or array of objects to the MATLAB double data type. The action taken by the `double` function depends on the class of the object you specify:

- If the object is an instance of a numeric class (`java.lang.Number` or one of the classes that inherit from that class), then MATLAB uses a preset conversion algorithm to convert the object to a MATLAB double.
- If the object is not an instance of a numeric class, MATLAB checks the class definition to see if it implements a method called `toDouble`. Note that MATLAB uses `toDouble` to perform its conversion of Java objects to the MATLAB double data type. If such a method is implemented for this class, MATLAB executes it to perform the conversion.
- If you are using a class of your own design, you can write your own `toDouble` method to perform conversions on objects of that class to a MATLAB double. This enables you to specify your own means of data type conversion for objects belonging to your own classes.

Note If the class of the specified object is not `java.lang.Number`, does not inherit from that `java.lang.Number`, and it does not implement a `toDouble` method, then an attempt to convert the object using the `double` function results in an error in MATLAB.

The syntax for the `double` command is as follows, where `object` is a Java object or Java array of objects.

```
double(object);
```

Converting to the MATLAB char Data Type

With the MATLAB `char` function, you can convert `java.lang.String` objects and arrays to MATLAB data types. A single `java.lang.String` object converts to a MATLAB character array. An array of `java.lang.String` objects converts to a MATLAB cell array, with each cell holding a character array.

If the object specified in the `char` command is not an instance of the `java.lang.String` class, then MATLAB checks its class to see if it implements a method named `toChar`. If this is the case, then MATLAB executes the `toChar`

method of the class to perform the conversion. If you write your own class definitions, then you can make use of this feature by writing a `toChar` method that performs the conversion according to your own needs.

Note If the class of the specified object is not `java.lang.String` and it does not implement a `toChar` method, then an attempt to convert the object using the `char` function results in an error in MATLAB.

The syntax for the `char` command is as follows, where `object` is a Java object or Java array of objects.

```
char(object);
```

Converting to a MATLAB Structure

Java objects are similar to the MATLAB structure in that many of an object's characteristics are accessible via field names defined within the object. You may want to convert a Java object into a MATLAB structure to facilitate the handling of its data in MATLAB. Use the MATLAB `struct` function on the object to do this.

The syntax for the `struct` command is as follows, where `object` is a Java object or Java array of objects.

```
struct(object);
```

The following example converts a `java.awt.Polygon` object into a MATLAB structure. You can access the fields of the object directly using MATLAB structure operations. The last line indexes into the array, `pstruct.xpoints`, to deposit a new value into the third array element.

```
polygon = java.awt.Polygon([14 42 98 124], [55 12 -2 62], 4);

pstruct = struct(polygon)
pstruct =
    npoints: 4
    xpoints: [4x1 int32]
    ypoints: [4x1 int32]
```

```
pstruct.xpoints
ans =
    14
    42
    98
   124

pstruct.xpoints(3) = 101;
```

Converting to a MATLAB Cell Array

Use the `cell` function to convert a Java array or Java object into a MATLAB cell array. Elements of the resulting cell array will be of the MATLAB type (if any) closest to the Java array elements or Java object.

The syntax for the `cell` command is as follows, where `object` is a Java object or Java array of objects.

```
cell(object);
```

In the following example, a MATLAB cell array is created in which each cell holds an array of a different data type. The `cell` command used in the first line converts each type of object array into a cell array.

```
import java.lang.* java.awt.*;

% Create a Java array of double
dblArray = javaArray('java.lang.Double', 1, 10);
for m = 1:10
    dblArray(1, m) = Double(m * 7);
end

% Create a Java array of points
ptArray = javaArray('java.awt.Point', 3);
ptArray(1) = Point(7.1, 22);
ptArray(2) = Point(5.2, 35);
ptArray(3) = Point(3.1, 49);

% Create a Java array of strings
strArray = javaArray('java.lang.String', 2, 2);
strArray(1,1) = String('one');    strArray(1,2) = String('two');
strArray(2,1) = String('three'); strArray(2,2) = String('four');
```



```
% Convert each to cell arrays
cellArray = {cell(dblArray), cell(ptArray), cell(strArray)}
cellArray =
    {1x10 cell}    {3x1 cell}    {2x2 cell}

cellArray{1,1}    % Array of type double
ans =

    [7]  [14]  [21]  [28]  [35]  [42]  [49]  [56]  [63]  [70]

cellArray{1,2}    % Array of type Java.awt.Point
ans =

    [1x1 java.awt.Point]
    [1x1 java.awt.Point]
    [1x1 java.awt.Point]

cellArray{1,3}    % Array of type char array
ans =

    'one'    'two'
    'three'  'four'
```

Introduction to Programming Examples

The following programming examples demonstrate the MATLAB interface to Java classes and objects:

- “Example – Reading a URL” on page 7-69
- “Example – Finding an Internet Protocol Address” on page 7-72
- “Example – Communicating Through a Serial Port” on page 7-74
- “Example – Creating and Using a Phone Book” on page 7-79

Each example contains the following sections:

- Overview - Describes what the example does and how it uses the Java interface to accomplish it. Highlighted are the most important Java objects that are constructed and used in the example code.
- Description - provides a detailed description of all code in the example. For longer functions, the description is divided into functional sections that focus on a few statements.
- Running the Example - Shows a sample of the output from execution of the example code.

The example descriptions concentrate on the Java-related functions. For information on other MATLAB programming constructs, operators, and functions used in the examples, see the applicable sections in the MATLAB documentation.

Example – Reading a URL

This program, `URLdemo`, opens a connection to a web site specified by a URL (Uniform Resource Locator), for the purpose of reading text from a file at that site. It constructs an object of the Java API class, `java.net.URL`, which enables convenient handling of URLs. Then, it calls a method on the URL object, to open a connection.

To read and display the lines of text at the site, `URLdemo` uses classes from the Java I/O package `java.io`. It creates an `InputStreamReader` object, and then uses that object to construct a `BufferedReader` object. Finally, it calls a method on the `BufferedReader` object to read the specified number of lines from the site.

Description of `URLdemo`

The major tasks performed by `URLdemo` are:

1. Construct a URL Object

The example first calls a constructor on `java.net.URL` and assigns the resulting object to variable `url`. The URL constructor takes a single argument, the name of the URL to be accessed, as a string. The constructor checks whether the input URL has a valid form.

```
url = java.net.URL(...  
    'http://www.mathworks.com/support/tech-notes/1100/1109.shtml')
```

2. Open a Connection to the URL

The second statement of the example calls the method, `openStream`, on the URL object `url`, to establish a connection with the web site named by the object. The method returns an `InputStream` object to variable, `is`, for reading bytes from the site.

```
is = openStream(url)
```

3. Set Up a Buffered Stream Reader

The next two lines create a buffered stream reader for characters. The `java.io.InputStreamReader` constructor is called with the input stream `is`, to return to variable `isr` an object that can read characters. Then, the `java.io.BufferedReader` constructor is called with `isr`, to return a

BufferedReader object to variable `br`. A buffered reader provides for efficient reading of characters, arrays, and lines.

```
isr = java.io.InputStreamReader(is)
br = java.io.BufferedReader(isr)
```

4. Read and Display Lines of Text

The final statements read the initial lines of HTML text from the site, displaying only the first 4 lines that contain meaningful text. Within the MATLAB for statements, the `BufferedReader` method `readLine` reads each line of text (terminated by a return and/or line feed character) from the site.

```
for k = 1:108           % Skip initial HTML formatting lines
    s = readLine(br);
end

for k = 1:4            % Read the first 4 lines of text
    s = readLine(br)
end
```

Running the Example

When you run this example, you see output similar to the following.

```
url =
http://www.mathworks.com/support/tech-notes/1100/1109.shtml
is =
ice.net.CachedInputStream@7e700c
isr =
java.io.InputStreamReader@7e6696
br =
java.io.BufferedReader@7e5d1b
s =
    <p class="standard">This technical note provides an
introduction to vectorization techniques.
s =
    In order to understand some of the tricks available, an
introduction to
```

```
s =
    MATLAB indexing is provided. Then several vectorization
techniques are
s =
    discussed, in order of simplest to most complicated.
```

Example – Finding an Internet Protocol Address

The `resolveip` function returns either the name or address of an IP (internet protocol) host. If you pass `resolveip` a hostname, it returns the IP address. If you pass `resolveip` an IP address, it returns the hostname. The function uses the Java API class `java.net.InetAddress`, which enables you to find an IP address for a hostname, or the hostname for a given IP address, without making DNS calls.

`resolveip` calls a static method on the `InetAddress` class to obtain an `InetAddress` object. Then, it calls accessor methods on the `InetAddress` object to get the hostname and IP address for the input argument. It displays either the hostname or the IP address, depending on the program input argument.

Description of `resolveip`

The major tasks performed by `resolveip` are:

1. Create an `InetAddress` Object

Instead of constructors, the `java.net.InetAddress` class has static methods that return an instance of the class. The `try` statement calls one of those methods, `getByName`, passing the input argument that the user has passed to `resolveip`. The input argument can be either a hostname or an IP address. If `getByName` fails, the catch statement displays an error message.

```
function resolveip(input)
try
    address = java.net.InetAddress.getByName(input);
catch
    error(sprintf('Unknown host %s.', input));
end
```

2. Retrieve the Hostname and IP Address

The example uses calls to the `getHostName` and `getHostAddress` accessor functions on the `java.net.InetAddress` object, to obtain the hostname and IP address, respectively. These two functions return objects of class `java.lang.String`, so we use the `char` function to convert them to character arrays.

```
hostname = char(address.getHostName);
ipaddress = char(address.getHostAddress);
```

3. Display the Hostname or IP Address

The example uses the MATLAB `strcmp` function to compare the input argument to the resolved IP address. If it matches, MATLAB displays the hostname for the internet address. If the input does not match, MATLAB displays the IP address.

```
if strcmp(input,ipaddress)
    disp(sprintf('Host name of %s is %s', input, hostname));
else
    disp(sprintf('IP address of %s is %s', input, ipaddress));
end;
```

Running the Example

Here is an example of calling the `resolveip` function with a hostname.

```
resolveip ('www.mathworks.com')
IP address of www.mathworks.com is 144.212.100.10
```

Here is a call to the function with an IP address.

```
resolveip ('144.212.100.10')
Host name of 144.212.100.10 is www.mathworks.com
```

Example – Communicating Through a Serial Port

The `serialexample` program uses classes of the Java API `javax.comm` package, which support access to communications ports. After defining port configuration variables, `serialexample` constructs a `javax.comm.CommPortIdentifier` object, to manage the serial communications port. The program calls the `open` method on that object to return an object of the `javax.comm.SerialPort` class, which describes the low-level interface to the COM1 serial port, assumed to be connected to a Tektronix oscilloscope. (The example can be run without an oscilloscope.) The `serialexample` program then calls several methods on the `SerialPort` object to configure the serial port.

The `serialexample` program uses the I/O package `java.io`, to write to and read from the serial port. It calls a static method to return an `OutputStream` object for the serial port. It then passes that object to the constructor for `java.io.OutputStreamWriter`. It calls the `write` method on the `OutputStreamWriter` object to write a command to the serial port, which sets the contrast on the oscilloscope. It calls `write` again to write a command that checks the contrast. It then constructs an object of the `java.io.InputStreamWriter` class to read from the serial port.

It calls another static method on the `SerialPort` object to return an `OutputStream` object for the serial port. It calls a method on that object to get the number of bytes to read from the port. It passes the `InputStream` object to the constructor for `java.io.OutputStreamWriter`. Then, if there is data to read, it calls the `read` method on the `OutputStreamWriter` object to read the contrast data returned by the oscilloscope.

Note MATLAB also provides built-in serial port support, described in Chapter 10, “Serial Port I/O”.

Description of Serial Example

The major tasks performed by `serialexample` are:

1. Define Variables for Serial Port Configuration and Output

The first five statements define variables for configuring the serial port. The first statement defines the baud rate to be 9600, the second defines number of data bits to be 8, and the third defines the number of stop bits to be 1. The fourth statement defines parity to be off, and the fifth statement defines flow control (handshaking) to be off.

```
SerialPort_BAUD_9600 = 9600;
SerialPort_DATABITS_8 = 8;
SerialPort_STOPBITS_1 = 1;
SerialPort_PARITY_NONE = 0;
SerialPort_FLOWCTRL_NONE = 0;
```

The last variable definition sets the terminator character for writing to the serial port, to a carriage return.

```
terminator = char(13);
```

2. Create a CommPortIdentifier Object

Instead of constructors, the `javax.comm.CommPortIdentifier` class has static methods that return an instance of the class. The example calls one of these, `getPortIdentifier`, to return a `CommPortIdentifier` object for port COM1.

```
commPort = ...
javax.comm.CommPortIdentifier.getPortIdentifier('COM1');
```

3. Open the Serial Port

The example opens the serial port, by calling `open` on the `CommPortIdentifier` object `commPort`. The `open` call returns a `SerialPort` object, assigning it to `serialPort`. The first argument to `open` is the name (owner) for the port, the second argument is the name for the port, and the third argument is the number of milliseconds to wait for the open.

```
serialPort = open(commPort, 'serial', 1000);
```

4. Configure the Serial Port

The next three statements call configuration methods on the `SerialPort` object `serialPort`. The first statement calls `setSerialPortParams` to set the baud rate, data bits, stop bits, and parity. The next two statements call `setFlowControlMode` to set the flow control, and then `enableReceiveTimeout` to set the timeout for receiving data.

```
setSerialPortParams(serialPort, SerialPort_BAUD_9600,...  
SerialPort_DATABITS_8, SerialPort_STOPBITS_1,...  
SerialPort_PARITY_NONE);  
setFlowControlMode(serialPort, SerialPort_FLOWCTRL_NONE);  
enableReceiveTimeout(serialPort, 1000);
```

5. Set Up an Output Stream Writer

The example then calls a constructor to create and open a `java.io.OutputStreamWriter` object. The constructor call passes the `java.io.OutputStream` object, returned by a call to the `getOutputStream` method `serialPort`, and assigns the `OutputStreamWriter` object to `out`.

```
out = java.io.OutputStreamWriter(getOutputStream(serialPort));
```

6. Write Data to Serial Port and Close Output Stream

The example writes a string to the serial port, by calling `write` on the object `out`. The string is formed by concatenating (with MATLAB `[]` syntax) a command to set the oscilloscope's contrast to 45, with the command terminator that is required by the instrument. The next statement calls `flush` on `out` to flush the output stream.

```
write(out, ['Display:Contrast 45' terminator]);  
flush(out);
```

Then, the example again calls `write` on `out` to send another string to the serial port. This string is a query command, to determine the oscilloscope's contrast setting, concatenated with the command terminator. The example then calls `close` on the output stream.

```
write(out, ['Display:Contrast?' terminator]);  
close(out);
```

7. Open an Input Stream and Determine Number of Bytes to Read

To read the data expected from the oscilloscope in response to the contrast query, the example opens an input stream by calling the static method, `InputStream.getInputStream`, to obtain an `InputStream` object for the serial port. Then, the example calls the method `available` on the `InputStream` object, `in`, and assigns the returned number of bytes to `numAvail`.

```
in = getInputStream(serialPort);
numAvail = available(in);
```

8. Create an Input Stream Reader for the Serial Port

The example then calls a `java.io.InputStreamReader` constructor, with the `InputStream` object, `in`, and assigns the new object to `reader`.

```
reader = java.io.InputStreamReader(in);
```

9. Read Data from Serial Port and Close Reader

The example reads from the serial port, by calling the `read` method on the `InputStreamReader` object `reader` for each available byte. The `read` statement uses MATLAB array concatenation to add each newly read byte to the array of bytes already read. After reading the data, the example calls `close` on `reader` to close the input stream reader.

```
result = [];
for k = 1:numAvail
    result = [result read(reader)];
end
close(reader);
```

10. Close the Serial Port

The example closes the serial port, by calling `close` on the `serialPort` object.

```
close(serialPort);
```

11. Convert Input Argument to a MATLAB Character Array

The last statement of the example uses the MATLAB function, `char`, to convert the array input bytes (integers) to an array of characters:

```
result = char(result);
```

Running the `serialexample` Program

The value of `result` depends upon whether your system's COM1 port is cabled to an oscilloscope. If you have run the example with an oscilloscope, you see the result of reading the serial port.

```
result =  
45
```

If you run the example without an oscilloscope attached, there is no data to read. In that case, you see an empty character array.

```
result =  
''
```

Example – Creating and Using a Phone Book

The example's main function, `phonebook`, can be called either with no arguments, or with one argument, which is the key of an entry that exists in the phone book. The function first determines the directory to use for the phone book file.

If no phone book file exists, it creates one by constructing a `java.io.FileOutputStream` object, and then closing the output stream. Next, it creates a data dictionary by constructing an object of the Java API class, `java.util.Properties`, which is a subclass of `java.util.Hashtable` for storing key/value pairs in a hash table. For the `phonebook` program, the key is a name, and the value is one or more telephone numbers.

The `phonebook` function creates and opens an input stream for reading by constructing a `java.io.FileInputStream` object. It calls `load` on that object to load the hash table contents, if it exists. If the user passed the key to an entry to look up, it looks up the entry by calling `pb_lookup`, which finds and displays it. Then, the `phonebook` function returns.

If `phonebook` was called without the name argument, it then displays a textual menu of the available phone book actions:

- Look up an entry
- Add an entry
- Remove an entry
- Change the phone number(s) in an entry
- List all entries

The menu also has a selection to exit the program. The function uses MATLAB functions to display the menu and to input the user selection.

The `phonebook` function iterates accepting user selections and performing the requested phone book action until the user selects the menu entry to exit. The `phonebook` function then opens an output stream for the file by constructing a `java.io.FileOutputStream` object. It calls `save` on the object to write the current data dictionary to the phone book file. It finally closes the output stream and returns.

Description of Function `phonebook`

The major tasks performed by `phonebook` are:

1. Determine the Data Directory and Full Filename

The first statement assigns the phone book filename, 'myphonebook', to the variable `pname`. If the `phonebook` program is running on a PC, it calls the `java.lang.System` static method `getProperty` to find the directory to use for the data dictionary. This will be set to the user's current working directory. Otherwise, it uses MATLAB function `getenv` to determine the directory, using the system variable `HOME` which you can define beforehand to anything you like. It then assigns to `pname` the full pathname, consisting of the data directory and filename 'myphonebook'.

```
function phonebook(varargin)
pname = 'myphonebook'; % name of data dictionary
if ispc
    datadir = char(java.lang.System.getProperty('user.dir'));
else
    datadir = getenv('HOME');
end;
pname = fullfile(datadir, pname);
```

2. If Needed, Create a File Output Stream

If the `phonebook` file does not already exist, `phonebook` asks the user whether to create a new one. If the user answers `y`, `phonebook` creates a new phone book by constructing a `FileOutputStream` object. In the `try` clause of a `try-catch` block, the argument `pname` passed to the `FileOutputStream` constructor is the full name of the file that the constructor creates and opens. The next statement closes the file by calling `close` on the `FileOutputStream` object `FOS`. If the output stream constructor fails, the `catch` statement prints a message and terminates the program.

```
if ~exist(pname)
    disp(sprintf('Data file %s does not exist.', pname));
    r = input('Create a new phone book (y/n)?','s');
    if r == 'y',
        try
            FOS = java.io.FileOutputStream(pname);
            FOS.close
        catch
```

```

        error(sprintf('Failed to create %s', pbname));
    end;
else
    return;
end;
end;

```

3. Create a Hash Table

The example constructs a `java.util.Properties` object to serve as the hash table for the data dictionary.

```
pb_hhtable = java.util.Properties;
```

4. Create a File Input Stream

In a try block, the example invokes a `FileInputStream` constructor with the name of the phone book file, assigning the object to `FIS`. If the call fails, the catch statement displays an error message and terminates the program.

```

try
    FIS = java.io.FileInputStream(pbname);
catch
    error(sprintf('Failed to open %s for reading.', pbname));
end;

```

5. Load the Phone Book Keys and Close the File Input Stream

The example calls `load` on the `FileInputStream` object `FIS`, to load the phone book keys and their values (if any) into the hash table. It then closes the file input stream.

```

pb_hhtable.load(FIS);
FIS.close;

```

6. Display the Action Menu and Get the User's Selection

Within a while loop, several `disp` statements display a menu of actions that the user can perform on the phone book. Then, an input statement requests the user's typed selection.

```

while 1
    disp ' '
    disp ' Phonebook Menu:'

```

```
disp ' '  
disp ' 1. Look up a phone number'  
disp ' 2. Add an entry to the phone book'  
disp ' 3. Remove an entry from the phone book'  
disp ' 4. Change the contents of an entry in the phone book'  
disp ' 5. Display entire contents of the phone book'  
disp ' 6. Exit this program'  
disp ' '  
s = input('Please type the number for a menu selection: ','s');
```

7. Invoke the Function to Perform A Phone Book Action

Still within the while loop, a switch statement provides a case to handle each user selection. Each of the first five cases invokes the function to perform a phone book action.

Case 1 prompts for a name that is a key to an entry. It calls `isempty` to determine whether the user has entered a name. If a name has not been entered, it calls `disp` to display an error message. If a name has been input, it passes it to `pb_lookup`. The `pb_lookup` routine looks up the entry and, if it finds it, displays the entry contents.

```
switch s  
    case '1',  
        name = input('Enter the name to look up: ','s');  
        if isempty(name)  
            disp 'No name entered'  
        else  
            pb_lookup(pb_htable, name);  
        end;
```

Case 2 calls `pb_add`, which prompts the user for a new entry and then adds it to the phone book.

```
case '2',
    pb_add(pb_htable);
```

Case 3 uses `input` to prompt for the name of an entry to remove. If a name has not been entered, it calls `disp` to display an error message. If a name has been input, it passes it to `pb_remove`.

```
case '3',
    name=input('Enter the name of the entry to remove: ', 's');
    if isempty(name)
        disp 'No name entered'
    else
        pb_remove(pb_htable, name);
    end;
```

Case 4 uses `input` to prompt for the name of an entry to change. If a name has not been entered, it calls `disp` to display an error message. If a name has been input, it passes it to `pb_change`.

```
case '4',
    name=input('Enter the name of the entry to change: ', 's');
    if isempty(name)
        disp 'No name entered'
    else
        pb_change(pb_htable, name);
    end;
```

Case 5 calls `pb_listall` to display all entries.

```
case '5',
    pb_listall(pb_htable);
```

8. Exit by Creating an Output Stream and Saving the Phone Book

If the user has selected case 6 to exit the program, a `try` statement calls the constructor for a `FileOutputStream` object, passing it the name of the phone book. If the constructor fails, the `catch` statement displays an error message.

If the object is created, the next statement saves the phone book data by calling `save` on the `Properties` object `pb_htable`, passing the `FileOutputStream`

object FOS and a descriptive header string. It then calls `close` on the `FileOutputStream` object, and returns.

```
    case '6',
        try
            FOS = java.io.FileOutputStream(pbname);
        catch
            error(sprintf('Failed to open %s for writing.',...
                          pbname));
        end;
        pb_htable.save(FOS,'Data file for phonebook program');
        FOS.close;
        return;
    otherwise
        disp 'That selection is not on the menu.'
    end;
end;
```

Description of Function `pb_lookup`

Arguments passed to `pb_lookup` are the Properties object `pb_htable` and the name key for the requested entry. The `pb_lookup` function first calls `get` on `pb_htable` with the name key, on which support function `pb_keyfilter` is called to change spaces to underscores. The `get` method returns the entry (or null, if the entry is not found) to variable `entry`. Note that `get` takes an argument of type `java.lang.Object` and also returns an argument of that type. In this invocation, the key passed to `get` and the entry returned from it are actually character arrays.

`pb_lookup` then calls `isempty` to determine whether `entry` is null. If it is, it uses `disp` to display a message stating that the name was not found. If `entry` is not null, it calls `pb_display` to display the entry.

```
function pb_lookup(pb_htable,name)
entry = pb_htable.get(pb_keyfilter(name));
if isempty(entry),
    disp(sprintf('The name %s is not in the phone book',name));
else
    pb_display(entry);
end
```

Description of Function `pb_add`

1. Input the Entry to Add

The `pb_add` function takes one argument, the Properties object `pb_htable`. `pb_add` uses `disp` to prompt for an entry. Using the up-arrow (^) character as a line delimiter, `input` inputs a name to the variable `entry`. Then, within a while loop, it uses `input` to get another line of the entry into variable `line`. If the line is empty, indicating that the user has finished the entry, the code breaks out of the while loop. If the line is not empty, the else statement appends `line` to `entry` and then appends the line delimiter. At the end, the `strcmp` checks the possibility that no input was entered and, if that is the case, returns.

```
function pb_add(pb_htable)
    disp 'Type the name for the new entry, followed by Enter.'
    disp 'Then, type the phone number(s), one per line.'
    disp 'To complete the entry, type an extra Enter.'
    name = input(':: ', 's');
    entry=[name '^'];
    while 1
        line = input(':: ', 's');
        if isempty(line)
            break;
        else
            entry=[entry line '^'];
        end;
    end;

    if strcmp(entry, '^')
        disp 'No name entered'
        return;
    end;
end;
```

2. Add the Entry to the Phone Book

After the input has completed, `pb_add` calls `put` on `pb_htable` with the hash key name (on which `pb_keyfilter` is called to change spaces to underscores) and `entry`. It then displays a message that the entry has been added.

```
pb_htable.put(pb_keyfilter(name), entry);
disp ' '
disp(sprintf('%s has been added to the phone book.', name));
```

Description of Function `pb_remove`

1. Look For the Key in the Phone Book

Arguments passed to `pb_remove` are the Properties object `pb_htable` and the name `key` for the entry to remove. The `pb_remove` function calls `containsKey` on `pb_htable` with the name `key`, on which support function `pb_keyfilter` is called to change spaces to underscores. If `name` is not in the phone book, `disp` displays a message and the function returns.

```
function pb_remove(pb_htable,name)
if ~pb_htable.containsKey(pb_keyfilter(name))
    disp(sprintf('The name %s is not in the phone book',name))
    return
end;
```

2. Ask for Confirmation and If Given, Remove the Key

If the key is in the hash table, `pb_remove` asks for user confirmation. If the user confirms the removal by entering `y`, `pb_remove` calls `remove` on `pb_htable` with the (filtered) name `key`, and displays a message that the entry has been removed. If the user enters `n`, the removal is not performed and `disp` displays a message that the removal has not been performed.

```
r = input(sprintf('Remove entry %s (y/n)? ',name), 's');
if r == 'y'
    pb_htable.remove(pb_keyfilter(name));
    disp(sprintf('%s has been removed from the phone book',name))
else
    disp(sprintf('%s has not been removed',name))
end;
```

Description of Function `pb_change`

1. Find the Entry to Change, and Confirm

Arguments passed to `pb_change` are the Properties object `pb_htable` and the name `key` for the requested entry. The `pb_change` function calls `get` on `pb_htable` with the name `key`, on which `pb_keyfilter` is called to change spaces to underscores. The `get` method returns the entry (or `null`, if the entry is not found) to variable `entry`. `pb_change` calls `isempty` to determine whether the entry is empty. If the entry is empty, `pb_change` displays a message that

the name will be added to the phone book, and allows the user to enter the phone number(s) for the entry.

If the entry is found, in the else clause, `pb_change` calls `pb_display` to display the entry. It then uses `input` to ask the user to confirm the replacement. If the user enters anything other than `y`, the function returns.

```
function pb_change(pb_htable,name)
entry = pb_htable.get(pb_keyfilter(name));
if isempty(entry)
    disp(sprintf('The name %s is not in the phone book', name));
    return;
else
    pb_display(entry);
    r = input('Replace phone numbers in this entry (y/n)? ','s');
    if r ~= 'y'
        return;
    end;
end;
```

2. Input New Phone Number(s) and Change the Phone Book Entry

`pb_change` uses `disp` to display a prompt for new phone number(s). Then, `pb_change` inputs data into variable `entry`, with the same statements described in “1. Input the Entry to Add” on page 7-85.

Then, to replace the existing entry with the new one, `pb_change` calls `put` on `pb_htable` with the (filtered) key name and the new entry. It then displays a message that the entry has been changed.

```
disp 'Type in the new phone number(s), one per line.'
disp 'To complete the entry, type an extra Enter.'
disp(sprintf(':: %s', name));
entry=[name '^'];
while 1
    line = input(':: ','s');
    if isempty(line)
        break;
    else
        entry=[entry line '^'];
    end;
end;
```

```
pb_htable.put(pb_keyfilter(name),entry);  
disp ' '  
disp(sprintf('The entry for %s has been changed', name));
```

Description of Function `pb_listall`

The `pb_listall` function takes one argument, the Properties object `pb_htable`. The function calls `propertyNames` on the `pb_htable` object to return to enum a `java.util.Enumeration` object, which supports convenient enumeration of all the keys. In a while loop, `pb_listall` calls `hasMoreElements` on `enum`, and if it returns true, `pb_listall` calls `nextElement` on `enum` to return the next key. It then calls `pb_display` to display the key and entry, which it retrieves by calling `get` on `pb_htable` with the key.

```
function pb_listall(pb_htable)  
enum = pb_htable.propertyNames;  
while enum.hasMoreElements  
    key = enum.nextElement;  
    pb_display(pb_htable.get(key));  
end;
```

Description of Function `pb_display`

The `pb_display` function takes an argument `entry`, which is a phone book entry. After displaying a horizontal line, `pb_display` calls MATLAB function `strtok` to extract the first line the entry, up to the line delimiter (^), into `t` and the remainder into `r`. Then, within a while loop that terminates when `t` is empty, it displays the current line in `t`. Then it calls `strtok` to extract the next line from `r`, into `t`. When all lines have been displayed, `pb_display` indicates the end of the entry by displaying another horizontal line.

```
function pb_display(entry)  
disp ' '  
disp '-----'  
[t,r] = strtok(entry, '^');  
while ~isempty(t)  
    disp(sprintf(' %s',t));  
    [t,r] = strtok(r, '^');  
end;  
disp '-----'
```

Description of Function `pb_keyfilter`

The `pb_keyfilter` function takes an argument `key`, which is a name used as a key in the hash table, and either filters it for storage or unfilters it for display. The filter, which replaces each space in the key with an underscore (`_`), makes the key usable with the methods of `java.util.Properties`.

```
function out = pb_keyfilter(key)
if ~isempty(findstr(key, ' '))
    out = strrep(key, ' ', '_');
else
    out = strrep(key, '_', ' ');
end;
```

Running the phonebook Program

In this sample run, a user invokes `phonebook` with no arguments. The user selects menu action 5, which displays the two entries currently in the phone book (all entries are fictitious). Then, the user selects 2, to add an entry. After adding the entry, the user again selects 5, which displays the new entry along with the other two entries.

Phonebook Menu:

1. Look up a phone number
2. Add an entry to the phone book
3. Remove an entry from the phone book
4. Change the contents of an entry in the phone book
5. Display entire contents of the phone book
6. Exit this program

Please type the number for a menu selection: 5

```
-----
Sylvia Woodland
(508) 111-3456
-----

-----
Russell Reddy
(617) 999-8765
-----
```

Phonebook Menu:

1. Look up a phone number
2. Add an entry to the phone book
3. Remove an entry from the phone book
4. Change the contents of an entry in the phone book
5. Display entire contents of the phone book
6. Exit this program

Please type the number for a menu selection: 2

Type the name for the new entry, followed by Enter.
Then, type the phone number(s), one per line.
To complete the entry, type an extra Enter.

```
:: BriteLites Books  
:: (781) 777-6868  
::
```

BriteLites Books has been added to the phone book.

Phonebook Menu:

1. Look up a phone number
2. Add an entry to the phone book
3. Remove an entry from the phone book
4. Change the contents of an entry in the phone book
5. Display entire contents of the phone book
6. Exit this program

Please type the number for a menu selection: 5

```
-----  
BriteLites Books  
(781) 777-6868  
-----
```

```
-----  
Sylvia Woodland
```

(508) 111-3456

Russell Reddy
(617) 999-8765

COM and DDE Support (Windows Only)

Component Object Model, or COM, is a set of object-oriented technologies and tools which allows software developers to integrate application-specific components from different vendors into their own application solution. COM support in MATLAB, available only on the Microsoft Windows platform, enables you to interact with contained controls or server processes, or to configure MATLAB as a computational server controlled by your client application programs.

Dynamic Data Exchange, or DDE, is a feature of Microsoft Windows which allows two programs to share data or send commands directly to each other. MATLAB provides functions that use this data exchange to enable access between MATLAB and other Windows applications in a wide range of contexts.

Introducing MATLAB COM Integration (p. 8-2)	COM Concepts and an overview of COM support in MATLAB
MATLAB COM Client Support (p. 8-10)	How to create COM objects and use properties, methods, and events
Additional COM Client Information (p. 8-66)	COM collections, converting data from MATLAB to COM, and using MATLAB as a DCOM server client
MATLAB Automation Server Support (p. 8-70)	Using MATLAB as a COM automation server
Additional Automation Server Information (p. 8-79)	Starting the MATLAB server, shared and dedicated servers, using MATLAB as a DCOM server
Dynamic Data Exchange (DDE) (p. 8-81)	DDE concepts, using MATLAB as a client or a server, DDE advisory links

Introducing **MATLAB COM** Integration

The *Component Object Model*, or COM, provides a framework for integrating reusable, binary software components into an application. Because components are implemented with compiled code, the source code may be written in any of the many programming languages that support COM. Upgrades to applications are simplified, as components can be simply swapped without the need to recompile the entire application. In addition, a component's location is transparent to the application, so components may be relocated to a separate process or even a remote system without having to modify the application.

Using COM, developers and end users can select application-specific components produced by different vendors and integrate them into a complete application solution. For example, a single application may require database access, mathematical analysis, and presentation-quality business graphs. Using COM, a developer may choose a database-access component by one vendor, a business graph component by another, and integrate these into a mathematical analysis package produced by yet a third.

This section of the documentation covers

- “Concepts and Terminology” on page 8-2
- “Supported Client/Server Configurations” on page 8-4
- “Registering Controls and Servers” on page 8-8

Concepts and Terminology

Here are some terms that you should be familiar with before reading this chapter.

COM Objects

A COM object is an instance of a component object class, or component. COM enforces complete encapsulation of the object, preventing its data and implementation from being accessed directly. The methods of an object must be accessed through an interface. A COM object runs in a server application that is controlled by one or more client applications.

Programmatic Identifier

When creating an instance of a COM component from within MATLAB, you refer to the component using its programmatic identifier, or ProgID. The ProgID is a string defined by the component vendor to uniquely define a particular COM component. You should be able to obtain this identifier from the vendor's documentation. The ProgID for MATLAB is `matlab.application`.

Interfaces

An interface provides access to the properties and methods of a COM object. In fact, the only way to access the internals of a COM object is through its interface. An interface does not contain any method implementation; it just serves as a pointer to the methods within the object.

Interfaces usually group a set of logically related methods together. An object may, and frequently does, *expose* (or make available) more than one interface. In order to use any COM object, you must learn about which interfaces it supports, and the methods, properties, and events implemented by the object. The component vendor provides this information.

IUnknown, IDispatch, Custom, and Dual Interfaces

The basic types of interfaces into COM objects are

- **IUnknown** — A basic industry standard interface that is required for all COM objects. All other interfaces are derived from IUnknown.
- **IDispatch** — An industry standard interface that employs a small set of functions to obtain information about and access to the properties and methods of a COM object.
- **Custom** — A user-defined interface that allows the client more direct, and thus faster, access to the server object's properties and methods.
- **Dual** — A combination of IDispatch and custom interfaces.

ActiveX Control

An ActiveX control is a component that has a user interface, enabling it to respond to actions taken by the user. A window that has **OK** and **Cancel** buttons can be implemented as a control, for example. A control runs in the process address space of its client application. The client is said to be a control *container* since it contains the control.

The client application is able to directly access the methods and properties of a control. The control must also be able to communicate back to the client. This enables it to notify the client application of an event occurrence, such as a mouse click.

In-Process and Out-of-Process Servers

You can configure a server in one of three ways. MATLAB supports all of these configurations:

- **In-Process Server** — A component that is implemented as a dynamic link library (DLL) or ActiveX control runs in the same process as the client application, sharing the same address space. This makes communication between client and server relatively simple and fast.
- **Local Out-of-Process Server** — A component that is implemented as an executable (.exe) file runs in a separate process from the client application. The client and server processes are on the same computer system. This configuration is somewhat slower due to the overhead required when transferring data across process boundaries.
- **Remote Out-of-Process Server** — This is another type of out-of-process server but, in this case, the client and server processes are on different systems and communicate over a network. Network communications, in addition to the overhead required for data transfer between processes, can make this configuration slower than the local out-of-process configuration. You can use this type of configuration only on systems that support the *Distributed Component Object Model* (DCOM).

Supported Client/Server Configurations

You can configure MATLAB to either control or be controlled by other COM components. When MATLAB controls another component, MATLAB is the client, and the other component is the server. When MATLAB is controlled by another component, it is acting as the server.

MATLAB supports four different COM client-server configurations that are explained in this section:

- “MATLAB Client and In-Process Server” on page 8-5
- “MATLAB Client and Out-of-Process Server” on page 8-6
- “Client Application and MATLAB Automation Server” on page 8-7

- “Client Application and MATLAB Engine Server” on page 8-8

MATLAB Client and In-Process Server

With the configuration shown below, the MATLAB client application interacts with a component that has been implemented as an ActiveX control or a dynamic link library (DLL). The server runs in the same process and shares the same address space as the client. Communication between client and server is fast because passing data within the same process requires little overhead.

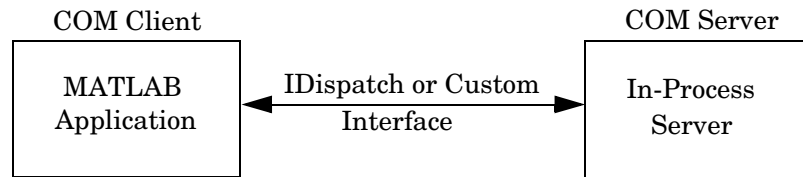

The server exposes its properties and methods through the IDispatch (Automation) interface or a custom interface, depending on which of these interfaces are implemented in the component. See “Getting Interfaces to the Object” on page 8-19 for information on accessing interfaces.

ActiveX Controls. An ActiveX control is an object that usually has some type of graphical user interface (GUI). When MATLAB constructs a control in the server, it places the control’s GUI within a MATLAB figure window to enable you to interact with it. By clicking on the various options available in the user interface (e.g., making a particular menu selection), you can trigger *events* that get communicated from the control in the server to the client MATLAB application. The client decides what to do about each event and responds accordingly.

MATLAB ships with a simple sample ActiveX control that draws a circle on the screen and displays some text. This allows MATLAB users to try out MATLAB COM control support with a known control. For more information, see “MATLAB Sample Control” on page 8-61.

DLL Servers. Any COM component that has been implemented as a dynamic link library (DLL) is also instantiated in an in-process server. That is, it is created

in the same process as the MATLAB client application. Unlike a control, the DLL server runs in a separate window rather than a MATLAB figure window.

MATLAB responds to events generated by a DLL server in the same way as events from an ActiveX control.

For More Information. To learn more about working with MATLAB as a client, see “MATLAB COM Client Support” on page 8-10 and “Additional COM Client Information” on page 8-66.

MATLAB Client and Out-of-Process Server

In this configuration, a MATLAB client application interacts with a component that has been implemented as an executable (.exe) file. The executable component is instantiated in a server that runs in a separate process from that of the client application. Communication between client and server is somewhat slower because of the overhead required when passing data across process boundaries. Examples of local servers are Microsoft Excel and Microsoft Word.

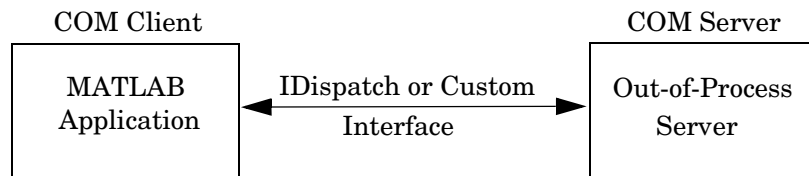

As with in-process servers, this server exposes its properties and methods through the IDispatch (Automation) interface or a custom interface, depending on which of these interfaces are implemented in the component. See “Getting Interfaces to the Object” on page 8-19 for information on accessing interfaces.

Since the client and server run in separate processes, you have the option of creating the server on any system on the same network as the client. This type of configuration is supported only in an environment that supports the Distributed Component Object Model (DCOM).

If the component provides a user interface, this interface is displayed in a separate window from the client application.

MATLAB responds to events generated by an out-of-process server in the same way as events from an ActiveX control.

For More Information. To learn more about working with MATLAB as a client, see “MATLAB COM Client Support” on page 8-10 and “Additional COM Client Information” on page 8-66.

Client Application and MATLAB Automation Server

MATLAB operates as the Automation server in this configuration. It can be created and controlled by any Windows program that can be an *Automation controller*. Some examples of applications that can be Automation controllers are Microsoft Excel, Microsoft Access, Microsoft Project, and many Visual Basic and Visual C++ programs.

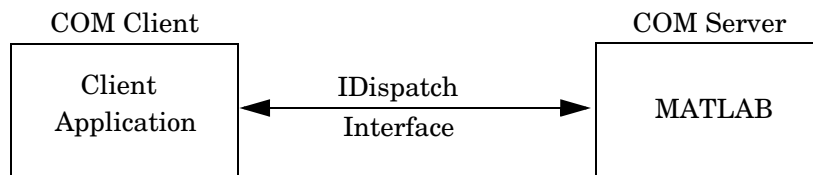

MATLAB Automation server capabilities include the ability to execute commands in the MATLAB workspace, and to get and put matrices directly from and into the workspace. You can start a MATLAB server to run in either a shared or dedicated mode. You also have the option of running it on a local or remote system.

To create the MATLAB server from an external application program, use the appropriate function from that language to instantiate the server. (For example, you would use the `CreateObject` function in Visual Basic.) For the programmatic identifier, specify `matlab.application`. To run MATLAB as a dedicated server, specify `matlab.application.single` as the identifier.

The function that creates the MATLAB server also returns a handle to the properties and methods available in the server through the `IDispatch` interface. See “COM Server Functions” for descriptions of these methods and how to call them from a Visual Basic or MATLAB client.

Note Because VBScript client programs require an Automation interface to communicate with servers, this is the only configuration that will support a VBScript client.

For More Information. To learn more about working with MATLAB Automation servers, see “MATLAB Automation Server Support” on page 8-70 and “Additional Automation Server Information” on page 8-79.

Client Application and MATLAB Engine Server

MATLAB provides a faster, custom interface called IEngine for client applications that are written in C, C++, or Fortran. MATLAB uses IEngine to communicate between the client application and the MATLAB Engine running as a COM server.

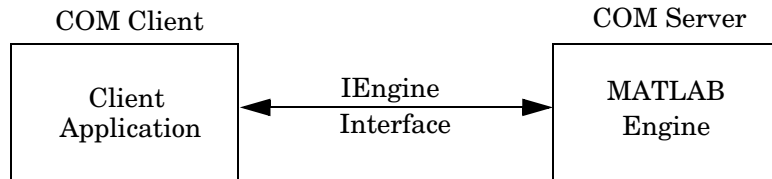

A library of functions is provided with MATLAB that enables you to start and end the server process, and to send commands to be processed by MATLAB. See “C Engine Functions” and “Fortran Engine Functions” in the External Interfaces Reference for more information on these.

For More Information. To learn more about the MATLAB Engine and the functions provided in its C and Fortran libraries, see Chapter 6, “Calling MATLAB from C and Fortran Programs.”

Registering Controls and Servers

Most controls and servers are registered by default. However, if you get a new .ocx, .dll, or other object file for the control or server, you must register the file manually.

Use the DOS `regsvr32` command to register your object file (e.g., `ocx` file), in the Windows registry. From the DOS prompt, use the `cd` function to go to the directory where the `ocx` file is located and use the syntax

```
regsvr32 filename.ocx
```

For example, to register the `mwsamp2.ocx` file used in many of the MATLAB documentation examples, type

```
regsvr32 mwsamp2.ocx
```

If you encounter problems with this procedure, please consult a Windows manual or contact your local system administrator.

Verifying the Registration

Here are several ways to verify that a control or server is registered (using the MATLAB `mwsamp` control as an example):

- Go to the Microsoft Visual C++ (MSVC) 6.0 tools menu and execute the ActiveX control test container. Click **Edit**, insert a new control, and select `MwSamp Control1`. If you are able to insert the control without any problems, the control is successfully registered. Note that this method only works on controls.
- Open the Registry Editor by typing `regedit` at the DOS prompt. You can then search for your control or server object by selecting **Find** from the **Edit** menu. It will likely be in the following structure:

```
HKEY_CLASSES_ROOT/progid
```

- Open `OLEViewer` from the MSVC 6.0 tools menu. Look in the following structure for your Control object:

```
Object Classes : Grouped by Component Category : Control :  
Your_Control_Object_Name (i.e. Object Classes : Grouped by  
Component Category : Control : Mwsamp Control)
```

MATLAB COM Client Support

This section introduces the MATLAB functions you need to create, manipulate, and destroy COM control and server objects. These objects are instances of the MATLAB COM class. The topics covered here are

- “Creating the Server Process — an Overview” on page 8-10
- “Creating an ActiveX Control” on page 8-12
- “Instantiating a DLL Component” on page 8-18
- “Instantiating an EXE Component” on page 8-18
- “Getting Interfaces to the Object” on page 8-19
- “Invoking Commands on a COM Object” on page 8-22
- “Identifying Objects and Interfaces” on page 8-26
- “Invoking Methods” on page 8-27
- “Object Properties” on page 8-33
- “Control and Server Events” on page 8-43
- “Writing Event Handlers” on page 8-52
- “Saving Your Work” on page 8-58
- “Releasing COM Interfaces and Objects” on page 8-59
- “Identifying Objects” on page 8-59
- “Examples of MATLAB as an Automation Client” on page 8-61

MATLAB includes three demos showing how to use the COM client interface. To run any of the demos, click on the **Demos** tab in the MATLAB Help browser. Then click to expand the folder called Automation Client Interface (COM).

Creating the Server Process — an Overview

MATLAB provides two functions to enable the MATLAB COM client to create an instance of the COM component in a server process:

- `actxcontrol` — Creates an ActiveX control in a MATLAB figure window.
- `actxserver` — Creates an in-process server for a dynamic link library (DLL) component or an out-of-process server for an executable (EXE) component.

The diagram below shows the basic steps in creating the server process. For more information on how MATLAB establishes interfaces to the resultant COM object, see “Getting Interfaces to the Object” on page 8-19.

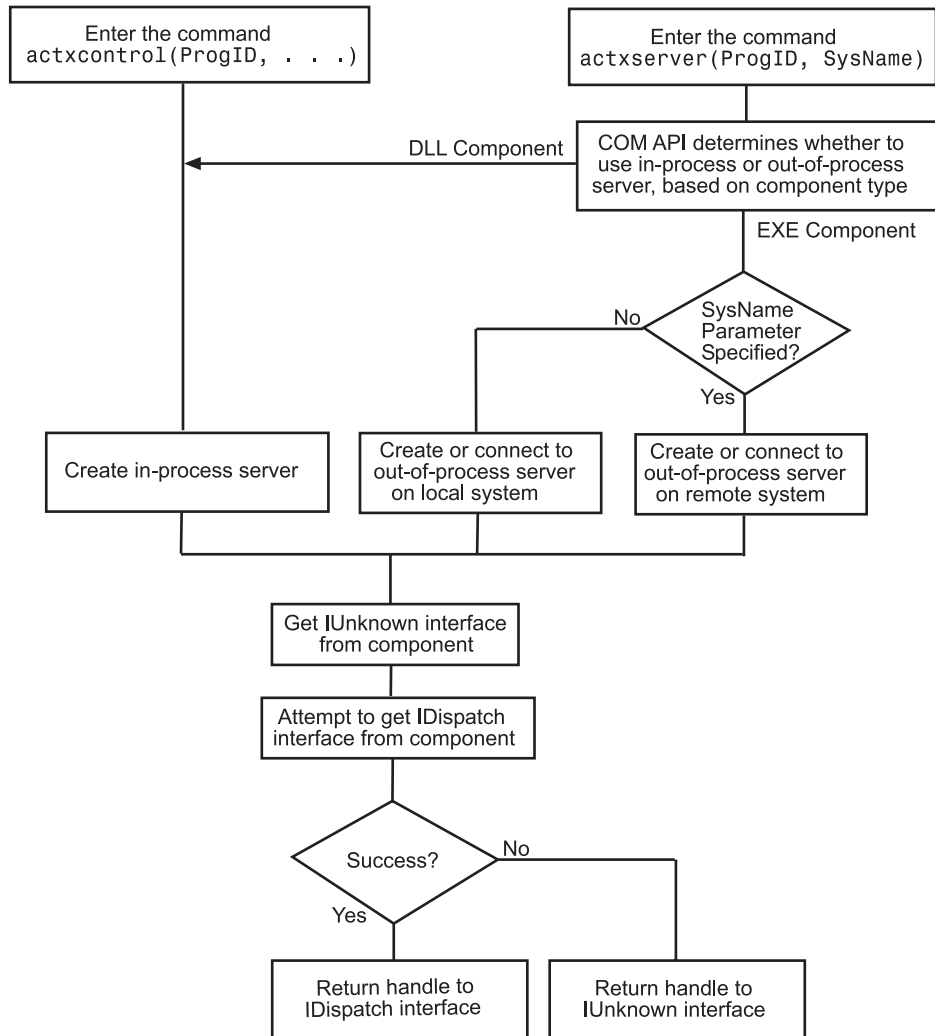

Creating an ActiveX Control

You can create an ActiveX control from the MATLAB client using either a graphical user interface or the `actxcontrol` function directly from the command line. Either of these methods creates an instance of the control in the MATLAB client process and returns a handle to the primary interface to the COM object. Through this interface, you can then access any public property or method of the object. You can also establish additional interfaces to the object, including interfaces that use `IDispatch` and any custom interfaces that may exist.

This section covers the following topics describing how to create the control in the client process and how to position its physical representation in the MATLAB figure window:

- “Finding Out What Controls Are Installed” on page 8-12
- “Creating Control Objects Using a Graphical Interface” on page 8-13
- “Creating Control Objects from the Command Line” on page 8-16
- “Repositioning the Control in a Figure Window” on page 8-17

Note If you encounter problems creating Microsoft Forms 2.0 controls in MATLAB or other non-VBA container applications, see “Using Microsoft Forms 2.0 Controls” on page 8-17

Finding Out What Controls Are Installed

The `actxcontrollist` function enables you to see what COM controls are currently installed on your system. Type

```
list = actxcontrollist;
```

and MATLAB returns a list of each control, including its name, programmatic identifier (or ProgID), and filename, in the output cell array.

Here is an example of the information that might be returned for several controls:

```
list = actxcontrollist;
```

```
for k = 114:115
```

```
s=sprintf(' Name = %s\n ProgID = %s\n File = %s\n', list{k,:})
end

s =
    Name = Mwsamp2 Control
    ProgID = MWSAMP.MwsampCtrl.2
    File = D:\R14\bin\win32\mwsamp2.ocx

ans =
    Name = NetMeeting Application
    ProgID = NetMeeting.App.1
    File = C:\WINNT\System32\msconf.dll
```

Creating Control Objects Using a Graphical Interface

The simplest way to create a control object is using the `actxcontrolselect` function. This function displays a graphical user interface that lists all controls installed on your system. When you select an item from the list and click the **Create** button, MATLAB creates the control and returns a handle to it:

```
h = actxcontrolselect
```

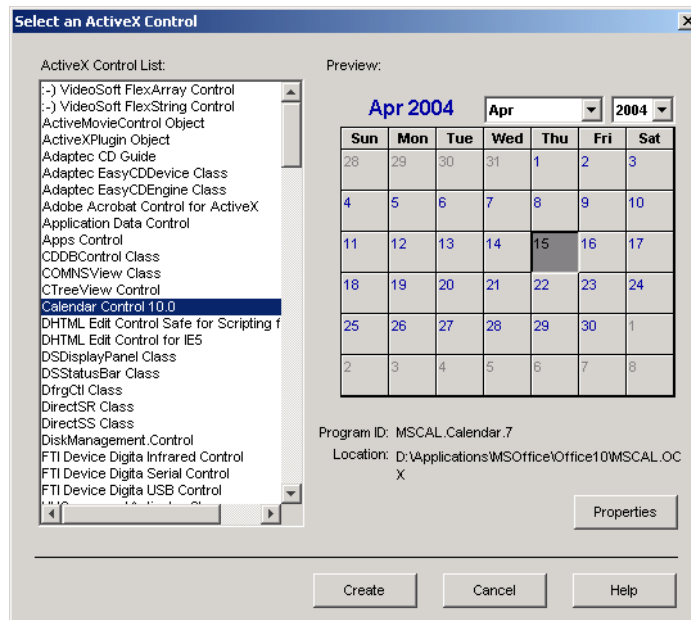

The interface has a selection panel at the left of the window and a preview panel at the right. Click on one of the control names in the selection panel to see a preview of the control displayed. (For controls that do not have a preview, the preview panel is blank). If MATLAB cannot create the control, an error message is displayed in the preview panel.)

Setting Properties with `actxcontrolselect`. Click the **Properties** button on the `actxcontrolselect` window to enter nondefault values for properties when creating the control. You can select which figure window to put the control in (**Parent** field), where to position it in the window (**X** and **Y** fields), and what size to make the control (**Width** and **Height**).

You can also register any events you want the control to respond to in this window. (See “Control and Server Events” on page 8-43 for an explanation of event registration). Register an event and the callback routine to handle that event by entering the name of the routine to the right of the event under **Callback M-File**.

You can also select callback routines by browsing for their respective M-files. Click a name in the **Event Names** column and then click the **Browse** button to select the callback for that event. To assign a callback routine to more than one event, press the **Ctrl** key and click on individual event names, or drag the mouse over consecutive event names, and then click **Browse** to select the callback routine.

MATLAB responds only to those events that are registered, so any events for which you do not specify a **Callback M-File** will be ignored when the event fires.

At the `actxcontrolselect` window, select **Calendar Control 10.0** and click **Properties** to see the window shown below. Enter a **Width** of 500 and a **Height** of 350 to change the default size for the control. Click **OK** in this window, and **Create** in the `actxcontrolselect` window to create the Calendar control.

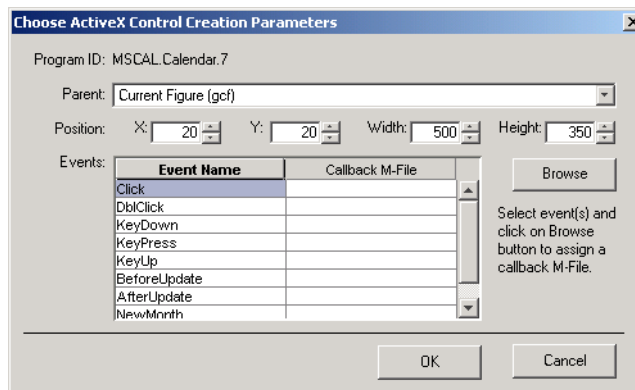

You can also set control parameters using the `actxcontrol` function. One parameter you can set with `actxcontrol` but not with `actxcontrolselect` is the name of an initialization file. When you specify this filename, MATLAB sets the initial state of the control to that of a previously saved control.

Information Returned by `actxcontrolselect`. `actxcontrolselect` creates an object that is an instance of the MATLAB COM class. The function returns up to two output arguments: a handle for the object, and a 1-by-3 cell array containing information about the control. These are shown here as `h` and `info`, respectively:

```
[h, info] = actxcontrolselect;
```

Use the handle to identify this particular control object when calling other MATLAB COM functions. The information returned in the cell array shows the name, ProgID, and filename for the control.

If you select Calendar Control 9.0 and then click **Create**, MATLAB returns

```
h =  
    COM.mscal.calendar.7  
info =  
    [1x20 char]    'MSCAL.Calendar.7'    [1x41 char]
```

Expand the `info` cell array to show the control name, ProgID, and filename.

```
info{:}  
ans =  
    Calendar Control 9.0  
ans =  
    MSCAL.Calendar.7  
ans =  
    D:\Applications\MSOffice\Office\MSCAL.OCX
```

Creating Control Objects from the Command Line

If you already know which control you want and you know its ProgID, you can bypass the graphical user interface by using the `actxcontrol` function to create it. (The ProgID is a string that is defined by the vendor and can be obtained from the vendor's documentation. For example, the ProgID for MATLAB is `matlab.application`.)

The only required input when calling the function is the ProgID. However, as with `actxcontrolselect`, you can supply additional inputs that enable you to select which figure window to put the control in, where to position it in the window, and what size to make it. You can also register any events you want the control to respond to, or set the initial state of the control by reading that state from a file. See the reference page on `actxcontrol` for a full explanation of its input arguments.

`actxcontrol` returns a handle to the primary interface to the object. Use this handle to reference the object in other COM function calls. You can also use the handle to obtain additional interfaces to the object. For more information on using interfaces, see "Getting Interfaces to the Object" on page 8-19.

This example creates a control to run a Microsoft Calendar application. Position the control in figure window `fig3`, at a `[0 0]` x-y offset from the bottom left of the window, and make it 300 by 400 pixels in size:

```
fig3 = figure('position', [50 50 600 500]);  
h = actxcontrol('mscal.calendar', [0 0 300 400], fig3)  
h =  
    COM.mscal.calendar
```

Repositioning the Control in a Figure Window

Once a control has been created, you can change its shape and position in the window with the `move` function.

Observe what happens to the object created in the last section when you specify new origin coordinates (70, 120) and new width and height dimensions of 400 and 350:

```
h.move([70 120 400 350]);
```

Using Microsoft Forms 2.0 Controls

You may encounter problems when creating or using Microsoft Forms 2.0 controls in MATLAB. Forms 2.0 controls were designed for use only with applications that are enabled by Visual Basic for Applications (VBA). Microsoft Office is one such application.

To work around these problems, you can use the replacement controls listed below, or consult article 236458 in the Microsoft Knowledge Base for further information:

<http://support.microsoft.com/?id=236458%22>.

Affected Controls. You may see this behavior with any of the following Forms 2.0 controls:

- `Forms.TextBox.1`
- `Forms.CheckBox.1`
- `Forms.CommandButton.1`
- `Forms.Image.1`
- `Forms.OptionButton.1`
- `Forms.ScrollBar.1`
- `Forms.SpinnerButton.1`

- Forms.TabStrip.1
- Forms.ToggleButton.1

Replacement Controls. The following replacements are recommended by Microsoft:

Old	New
Forms.TextBox.1	RichTEXT.RichtextCtrl.1
Forms.CheckBox.1	vidtc3.Checkbox
Forms.CommandButton.1	MSComCtl2.FlatScrollBar.2
Forms.TabStrip.1	COMCTL.TabStrip.1

Instantiating a DLL Component

To create a server for a component implemented as a dynamic link library (DLL), use the `actxserver` function. MATLAB creates an instance of the component in the same process that contains the client application.

The syntax for `actxserver`, when used with a DLL component, is

```
actxserver(ProgID)
```

where `ProgID` is the programmatic identifier for the component.

`actxserver` returns a handle to the primary interface to the object. Use this handle to reference the object in other COM function calls. You can also use the handle to obtain additional interfaces to the object. For more information on using interfaces, see “Getting Interfaces to the Object” on page 8-19.

Unlike ActiveX controls, any user interface that is displayed by the server appears in a separate window.

Instantiating an EXE Component

You also use the `actxserver` function to create a server for a component implemented as an executable (EXE). In this case, however, MATLAB instantiates the component in an out-of-process server.

The syntax for `actxserver` is

```
actxserver(ProgID, sysname)
```

where ProgID is the programmatic identifier for the component, and sysname is an optional argument used in configuring a distributed COM (DCOM) system (see the reference page for `actxserver`).

`actxserver` returns a handle to the primary interface to the COM object. Use this handle to reference the object in other COM function calls. You can also use the handle to obtain additional interfaces to the object. For more information on using interfaces, see “Getting Interfaces to the Object” on page 8-19.

Any user interface that is displayed by the server appears in a separate window.

This example creates a COM server application running Excel. The returned handle is assigned to `h`:

```
h = actxserver('excel.application')
h =
    COM.excel.application
```

Getting Interfaces to the Object

The COM component you are working with can provide different types of interfaces for accessing the object’s public properties and methods:

- The `IUnknown` and `IDispatch` interfaces
- One or more custom interfaces

IUnknown and IDispatch

When you invoke the `actxserver` or `actxcontrol` function, MATLAB creates the server and returns a handle to the server interface as a means of accessing its properties and methods. MATLAB uses the following process to determine which handle to return:

- 1** MATLAB first gets a handle to the `IUnknown` interface from the component. All COM components are required to implement at least this one interface.
- 2** MATLAB then attempts to get the `IDispatch` interface from the component. If `IDispatch` is implemented in the component, MATLAB returns a handle

to the IDispatch interface. If IDispatch is not implemented, MATLAB returns the handle to IUnknown.

Additional Interfaces. Components often provide additional interfaces, based on IDispatch, that are implemented as properties. Like any other property, you can obtain any of these interfaces using the MATLAB `get` function.

For example, a Microsoft Excel component contains numerous interfaces. You can list these interfaces, along with other Excel properties, using the MATLAB `get` function without any arguments:

```
h = actxserver('excel.application');

h.get
Application: [1x1 Interface.Microsoft_Excel_9.0_
Object_Library._Application]
Creator: 'xlCreatorCode'
Parent: [1x1 Interface.Microsoft_Excel_9.0_
Object_Library._Application]
ActiveCell: []
ActiveChart: [1x50 char]
.
.
```

To get a handle to a specific interface, specify an object or interface handle, `h` in the example below, and the name of the target interface, `Workbooks`:

```
w = h.Workbooks
w =
Interface.Microsoft_Excel_9.0_Object_Library.Workbooks
```

Custom Interfaces

The following two client/server configurations also support any custom interfaces that may be implemented in the component:

- “MATLAB Client and In-Process Server” on page 8-5
- “MATLAB Client and Out-of-Process Server” on page 8-6

Once you have created the server, you can query the server component to see if any custom interfaces are implemented. Use the `interfaces` function to return a list of all available custom interfaces. This list is returned in a cell array of strings:

```
h = actxserver('mytestenv.calculator')
h =
    COM.mytestenv.calculator

customlist = h.interfaces
customlist =
    ICalc1
    ICalc2
    ICalc3
```

To get a handle to the custom interface you want, use the `invoke` function, specifying the handle returned by `actxcontrol` or `actxserver`, and also the name of the custom interface:

```
c1 = h.invoke('ICalc1')
c1 =
    Interface.Calc_1.0_Type_Library.ICalc_Interface
```

You can now use this handle with most of the COM client functions to access the properties and methods of the object through the selected custom interface.

For example, to list the properties available through the `ICalc1` interface, use

```
c1.get
    background: 'Blue'
    height: 10
    width: 0
```

To list the methods, use

```
c1.invoke
    Add = double Add(handle, double, double)
    Divide = double Divide(handle, double, double)
    Multiply = double Multiply(handle, double, double)
    Subtract = double Subtract(handle, double, double)
```

Add and multiply numbers using the `Add` and `Multiply` methods of the custom object `c1`:

```
sum = c1.Add(4, 7)
sum =
    11
```

```
prod = c1.Multiply(4, 7)
prod =
    28
```

Invoking Commands on a COM Object

When invoking either MATLAB COM functions or methods belonging to COM objects, the simplest syntax to use is *dot syntax*. Specify the object name, the dot (`.`), and then the name of the function or method you are calling. Enclose any input arguments in parentheses after the function name. Specify output arguments to the left of the equals sign:

```
outputvalue = object.function(arg1, arg2, ...)
```

For further explanation of command syntax and alternative forms of syntax, see

- “An Example of Calling Syntax” on page 8-22
- “Specifying Property, Method, and Event Names” on page 8-23
- “Implicit Syntax for Calling get, set, and invoke” on page 8-24
- “Exceptions to Using Implicit Syntax” on page 8-24

An Example of Calling Syntax

To work with the example that follows, first create an ActiveX control called `mwsamp`. (The `mwsamp` control is built into MATLAB to enable you to work with the examples shown in the COM documentation. The control displays a circle and text label that you can manipulate from MATLAB).

Call `actxcontrol` to create the `mwsamp` control. This function returns a handle `h` that you will need to work further with the control.

```
h = actxcontrol('mwsamp.mwsampctr1.2', [200 120 200 200]);
```

Once you have a handle to an object, you can invoke MATLAB functions on the object by referencing it through the handle. This next statement invokes a function, `addproperty`, on the object using dot syntax. There is one input argument passed in the call, the string `'Position'`:

```
h.addproperty('Position');
```

An alternative syntax for the same operation begins with the function name and specifies the object handle `h` as the first argument in the argument list:

```
addproperty(h, 'Position');
```

MATLAB supports both of these command forms.

Specifying Property, Method, and Event Names

You can specify the names of properties and methods using the simple notation

```
handle.propertyname  
handle.methodname
```

For example, the `mwsamp` object has a property called `Radius` that represents the radius of the circle it draws, and a method called `Redraw` that redraws the circle. You can get the circle's radius by typing

```
h.Radius
```

You can redraw the circle with

```
h.Redraw
```

More information is provided on this in the following sections, “Implicit Syntax for Calling `get`, `set`, and `invoke`” on page 8-24 and “Exceptions to Using Implicit Syntax” on page 8-24. Here are a few specific rules regarding how to express property, method, and event names.

Property Names. You can abbreviate the names of properties, as long as you include enough characters in the name to distinguish it from another property. Property names are also case insensitive.

These two statements produce the same result:

```
x = h.Radius  
x = h.r
```

Method Names. Method names cannot be abbreviated and must be entered in the correct letter case.

Event Names. Event names are always specified as quoted strings in arguments to a function. Event names must be entered in full but are not sensitive to letter case.

These statements produce the same result:

```
h.registerevent({'MouseDown' 'mymoused'});
```

```
h.registerevent({'MOUSEdown' 'myMOUSEd'});
```

Implicit Syntax for Calling `get`, `set`, and `invoke`

When calling `get`, `set`, or `invoke` on a COM object, MATLAB provides a simpler syntax that doesn't require an explicit function call. You can use this shortened syntax in all but a few cases (see "Exceptions to Using Implicit Syntax" on page 8-24).

Continue with the `mwsamp` control created in the last section and represented by handle `h`. To get the value of `Radius` property and assign it to variable `x`, use the syntax shown here. MATLAB still makes the call to `get`, but this shortened syntax is somewhat easier to enter:

```
x = h.Radius
x =
    20
```

The same shortened syntax applies when calling the `set` and `invoke` functions. Compare these two ways of setting a new radius value for the circle and invoking the `Redraw` method of `mwsamp` to display the circle in its enlarged size. The commands on the left call `set` and `invoke` explicitly. The commands on the right make implicit calls:

```
h.set('Radius', 40);           h.Radius = 40;
h.invoke('Redraw');           h.Redraw;
```

Exceptions to Using Implicit Syntax

There are some conditions under which you must explicitly call `get`, `set`, and `invoke`:

- When the property or method is not public
- When accessing a property that takes arguments
- When operating on a vector of objects

Nonpublic properties and methods. If the property or method you want to access is not provided as a public property or method of the object class, or if it is not in the type library for the control or server, then you must call `get`, `set`, or `invoke` explicitly. For example, the `Visible` property of an Internet Explorer application is not public and must be accessed using `get` and `set`:

```
h = actxserver('internetexplorer.application');
```

```

% This syntax is invalid because 'Visible' is not public.
v = h.Visible
??? No appropriate method or public field Visible for class
    COM.internetexplorer.application.

% You must call the get function explicitly.
v = h.get('Visible')
v =
    1

% The same holds true when setting nonpublic properties.
h.set('Visible', 1);

```

Public properties and methods are those that are listed in response to the following commands on COM object h:

```

publicproperties = h.get
publicmethods = h.invoke

```

Accessing Properties That Take Arguments. Some COM objects have properties that behave somewhat like methods in that they accept input arguments. This is explained fully in the section “Properties That Take Arguments” on page 8-36. In order to get or set the value of such a property, you must make an explicit call to the get or set function, as shown here. In this example, A1 and B2 are arguments that specify which Range interface to return on the get operation:

```

eActivsheetRange = e.Activesheet.get('Range', 'A1', 'B2')
eActivsheetRange =
    Interface.Microsoft_Excel_5.0_Object_Library.Range

```

Operating on a Vector of Objects. If you operate on a vector of objects, (see “Get and Set on a Vector of Objects” on page 8-37), you must call get and set explicitly to access properties.

This example creates a vector of handles to two Microsoft Calendar objects. It then modifies the Day property of both objects in one operation by invoking set on the vector. Explicit calls to get and set are required:

```

h1 = actxcontrol('mscal.calendar', [0 200 250 200]);
h2 = actxcontrol('mscal.calendar', [250 200 250 200]);
H = [h1 h2];

```

```
H.set('Day', 23)
H.get('Day')
ans =
    [23]
    [23]
```

This applies only to get and set. You cannot invoke a method on more than one COM object at a time, even if you call `invoke` explicitly.

Identifying Objects and Interfaces

You can get some additional information about a control or server using the following functions.

Function	Description
<code>class</code>	Return the class of an object
<code>isa</code>	Determine if an object is of a given MATLAB class
<code>iscom</code>	Determine if the input is a COM or ActiveX object
<code>isinterface</code>	Determine if the input is a COM interface

This example creates a COM object in an Automation server running Excel, giving it the handle `h`, and a `Workbooks` interface to the object, with handle `w`.

```
h = actxserver('excel.application');
w = h.Workbooks;
```

Use the `iscom` function to see if variable `h` is a handle to a COM or ActiveX object:

```
h.iscom
ans =
    1
```

Use the `isa` function to test variable `h` against a known class name:

```
h.isa('COM.excel.application')
ans =
    1
```

Use `isinterface` to see if variable `w` is a handle to a COM interface:

```
w.isinterface
ans =
    1
```

Use the `class` function to find out the class of variable `w`:

```
w.class
ans =
    Interface.Microsoft_Excel_9.0_Object_Library.Workbooks
```

Invoking Methods

This section covers the following topics on how to invoke and pass arguments to class methods:

- “Functions for Working with Methods” on page 8-27
- “Listing the Methods of a Class or Object” on page 8-28
- “Invoking Methods on an Object” on page 8-29
- “Specifying Enumerated Parameters” on page 8-30
- “Optional Input Arguments” on page 8-31
- “Returning Multiple Output Arguments” on page 8-32
- “Argument Callouts in Error Messages” on page 8-33

Functions for Working with Methods

Use the following MATLAB functions to find out what methods a COM object has and to invoke any of these methods on the object.

Function	Description
<code>invoke</code>	Invoke a method or display a list of methods and types
<code>ismethod</code>	Determine if an item is a method of a COM object
<code>methods</code>	List all method names for the control or server
<code>methodsview</code>	GUI interface to list information on all methods and types

When using these functions, enter event names and event handler names as strings or in a cell array of strings. These names are case insensitive, but cannot be abbreviated.

Listing the Methods of a Class or Object

You can see what methods are supported by a control or server object either in a graphical display using the `methodsview` function, or in a returned cell array using the `methods` function.

Using `methodsview`. The `methodsview` function opens a new window with an easy to read display of all methods supported by the specified control or server object along with several related fields of information. Type the following to bring up a window such as the one shown below:

```
cal = actxcontrol('mscal.calendar', [0 0 400 400]);
cal.methodsview
```

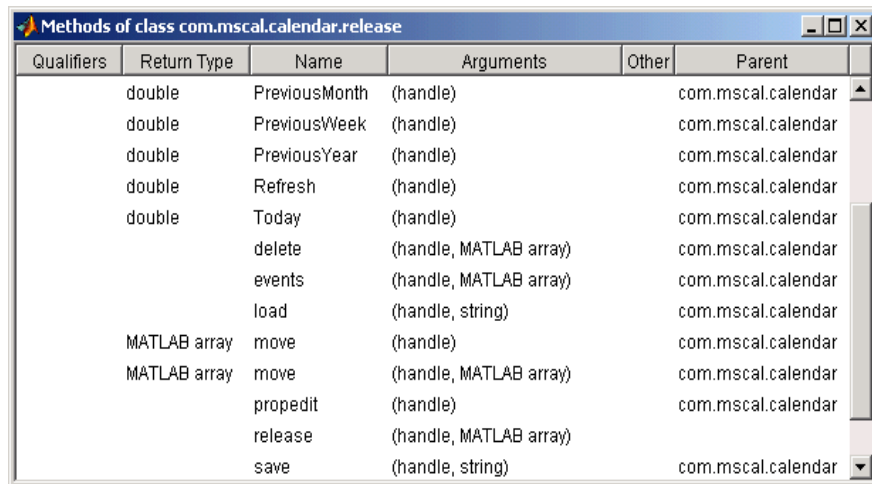

Qualifiers	Return Type	Name	Arguments	Other	Parent
	double	PreviousMonth	(handle)		com.mscal.calendar
	double	PreviousWeek	(handle)		com.mscal.calendar
	double	PreviousYear	(handle)		com.mscal.calendar
	double	Refresh	(handle)		com.mscal.calendar
	double	Today	(handle)		com.mscal.calendar
		delete	(handle, MATLAB array)		com.mscal.calendar
		events	(handle, MATLAB array)		com.mscal.calendar
		load	(handle, string)		com.mscal.calendar
	MATLAB array	move	(handle)		com.mscal.calendar
	MATLAB array	move	(handle, MATLAB array)		com.mscal.calendar
		propedit	(handle)		com.mscal.calendar
		release	(handle, MATLAB array)		com.mscal.calendar
		save	(handle, string)		com.mscal.calendar

Methods that return `void` show no **Return Type** in the display.

Using `methods`. The `methods` function returns in a cell array the names of all methods supported by the specified control or server object. This includes MATLAB COM functions that you can use on the object.

When you include the `-full` switch in the command, MATLAB also specifies the input and output arguments for each method:

```
cal.methods('-full')

Methods for class COM.mscal.calendar:

release(handle, MATLAB array)
delete(handle, MATLAB array)
MATLAB array events(handle, MATLAB array)
.
.
HRESULT Refresh(handle)
HRESULT Today(handle)
HRESULT AboutBox(handle)
```

The `invoke` function, when called with only a handle argument, returns a similar output.

Invoking Methods on an Object

To execute, or *invoke*, any method on an object, use either the MATLAB `invoke` function, or the somewhat simpler method name syntax.

Using `invoke`. The `invoke` function executes the specified method on an object. You can use either of the following syntaxes with `invoke`:

```
v = invoke(handle, 'methodname', 'arg1', 'arg2', ...);
v = handle.invoke('methodname', 'arg1', 'arg2', ...);
```

See the output of `methodsview` for a method to see what data types to use for input and output arguments.

The following example reads today's date and then advances it by 5 years by invoking the `NextYear` method in a loop.

To get today's date, type

```
cal = actxcontrol('mscal.calendar', [0 0 400 400]);
cal.Value
ans =
    11/5/2001
```

Call the `NextYear` method to advance the date, and then verify the results:

```
for k = 1:5
    cal.NextYear;
end

cal.Value
ans =
    11/5/2006
```

Using the Method Name. Instead of using `invoke`, you can just use the name of the method to call it. The syntax for calling by method name is

```
v = handle.methodname('arg1', 'arg2', ...);
```

Continuing the example shown in the last section, return to the original data by going back 5 years.

```
for k = 1:5
    cal.PreviousYear;
end

cal.Value
ans =
    11/5/2001
```

Specifying Enumerated Parameters

Enumeration is a way of representing a somewhat cryptic symbolic value by using a more descriptive name that makes it clear what the value stands for. For example, a program that takes atomic numbers of elements as input will be easier to work with if the program accepts element names as input rather than requiring you to recall and pass atomic numbers for each element. You could pass the word `'arsenic'` as an enumeration for the value 33.

MATLAB supports enumeration for parameters passed to methods under the condition that the type library in use reports the parameter as `ENUM`, and only as `ENUM`.

Note MATLAB does not support enumeration for any parameter that the type library reports as both ENUM and Optional.

The last line of this example passes an enumerated value ('xlLocationAsObject') to the Location method of a Microsoft Excel Chart object. You have the choice of passing the enumeration or its numeric equivalent:

```
e = actxserver('Excel.Application');

% Insert a new workbook.
Workbook = e.Workbooks.Add;
e.Visible = 1;
Sheets = e.ActiveWorkBook.Sheets;

% Get a handle to the active sheet.
Activsheet = e.Activesheet;

%Add a Chart
Charts = Workbook.Charts;
Chart = Charts.Add;

% Set chart type to be a line plot.
Chart.ChartType = 'xlXYScatterLines'
C1 = Chart.Location('xlLocationAsObject', 'Sheet1');
```

When you are dealing with only three numeric values, it is not that difficult to remember the meaning of each. But with programs that require a large number of such values, enumeration becomes more important.

Optional Input Arguments

When calling a method that takes optional input arguments, you can skip any optional argument by specifying an empty array ([]) in its place. The syntax for calling a method with second argument (arg2) not specified is as follows:

```
handle.methodname(arg1, [], arg3);
```

The example below invokes the Add method of an Excel object. This method adds new sheets to an Excel workbook. The Add method takes up to four optional input arguments:

- Before — The sheet before which to add the new sheet
- After — The sheet after which to add the new sheet
- Count — The total number of sheets to add
- Type — The type of sheet to add

The following code creates a workbook with the default number of worksheets, and then inserts an additional sheet after Sheet 1. To do this, you invoke Add specifying only the second argument, After. You can omit the first argument, Before, by using [] in its place. This is done on the last line:

```
% Open an Excel Server.
e = actxserver('excel.application');

% Insert a new workbook.
e.Workbooks.Add;
e.Visible = 1;

% Get the Active Workbook with three sheets.
eSheets = e.ActiveWorkbook.Sheets;

% Add a new sheet after eSheet1.
eSheet1 = eSheets.Item(1);
eNewSheet = eSheets.Add([], eSheet1);
```

Returning Multiple Output Arguments

If you know that a server function supports multiple outputs, you can return any or all of those outputs to a MATLAB client. Specify the output arguments within brackets on the left side of the equation. This gives the MATLAB client code access to any values returned by the server function.

The syntax shown here shows a server function being called by the MATLAB client. The function's return value is shown as retval. The function's output arguments (out1, out2, ...) follow this:

```
[retval out1 out2 ...] = handle.functionname(in1, in2, ...);
```

MATLAB makes use of the pass by reference capabilities in COM to implement this feature. Note that pass by reference is a COM feature. It is not available in MATLAB at this time.

Argument Callouts in Error Messages

When a MATLAB client sends a command with an invalid argument to a COM server application, the server sends back an error message similar to that shown here, identifying the invalid argument. Be careful when interpreting the argument callout in this type of message:

```
PutFullMatrix(handle, 'a', 'base', 7, [5 8]);  
??? Error: Type mismatch, argument 3.
```

In the `PutFullMatrix` command shown above, it is the fourth argument, 7, that is invalid. (It is scalar and not the expected array data type.) However, the error message identifies the failing argument as argument 3.

This is because the COM server receives only the last four of the arguments shown in the MATLAB code. (The `handle` argument merely identifies the server. It does not get passed to the server). So the server sees 'a' as the first argument, and the invalid argument, 7, as the third.

As another example, submitting the same command with the `invoke` function makes the invalid argument fifth in the MATLAB client code. Yet the server still identifies it as argument 3 because neither of the first two arguments is seen by the server:

```
invoke(handle, 'PutFullMatrix', 'a', 'base', 7, [5 8]);  
??? Error: Type mismatch, argument 3.
```

Object Properties

This section covers the following topics describing how to set and get the value of a property, and how to create custom properties:

- “Functions for Working with Object Properties” on page 8-34
- “Getting the Value of a Property” on page 8-34
- “Setting the Value of a Property” on page 8-36
- “Get and Set on a Vector of Objects” on page 8-37
- “Using Enumerated Values for Properties” on page 8-38
- “Using the Property Inspector” on page 8-40

- “Custom Properties” on page 8-42

Functions for Working with Object Properties

Use these MATLAB functions to get, set, and modify the properties of a COM object or interface, or to add your own custom properties.

Function	Description
addproperty	Add a custom property to a COM object
deleteproperty	Remove a custom property from a COM object
get	List one or more properties and their values
inspect	Display graphical interface to list and modify property values
isprop	Determine if an item is a property of a COM object
propedit	Display the control’s built-in property page
set	Set a property on an interface

Getting the Value of a Property

The get function returns information on one or more properties belonging to a COM object or interface. Use get with only the handle argument, and MATLAB returns a list of all properties for the object, and their values:

```
h = actxserver('excel.application');

h.get
  Application: [1x1 Interface.Microsoft_Excel_9.0_
Object_Library._Application]
    Creator: 'xlCreatorCode'
    Parent: [1x1 Interface.Microsoft_Excel_9.0_
Object_Library._Application]
  ActiveCell: []
  ActiveChart: [1x50 char]
      .
      .
```

To return the value of just one property, specify the object handle and property name using dot syntax:

```
company = h.OrganizationName
company =
    The MathWorks, Inc.
```

Property names are not case sensitive and may also be abbreviated, as long as you include enough letters in the name to make it unambiguous. You can use 'org' in place of the full 'OrganizationName' property name used above:

```
company = h.org
company =
    The MathWorks, Inc.
```

You can also use the `get` function, without dot syntax, for this same purpose:

```
filepath = h.get('DefaultFilePath')
filepath =
    H:\Documents
```

Getting Multiple Property Values. To get more than one property with just one command, you must use the `get` function, specifying the property names in a cell array of strings. This returns a cell array containing a column for each property value:

```
C = h.get({'prop1', 'prop2', ...});
```

For example, to get the `DefaultFilePath` and `UserName` property values for COM object `h`, use

```
h = actxserver('excel.application');

C = h.get({'DefaultFilePath', 'UserName'});
C{:}
ans =
    H:\Documents
ans =
    C. Coolidge
```

Setting the Value of a Property

The simplest way to set or modify the value of a property is just to use an assignment statement like that shown in the second line below. This sets the value of the `DefaultFilePath` property for object `h` to `'C:\ExcelWork'`:

```
h = actxserver('excel.application');  
h.DefaultFilePath = 'C:\ExcelWork';
```

You can also use the `set` function, without dot syntax, for this same purpose. Specify both the property name and new value as input arguments to `set`:

```
h.set('DefaultFilePath', 'C:\ExcelWork');
```

Setting Multiple Property Values. To change more than one property with just one command, you must use the `set` function:

```
h.set('prop1', 'value1', 'prop2', 'value2', ...);
```

For example, to set the `DefaultFilePath` and `UserName` fields of COM object `h`, use

```
h = actxserver('excel.application');  
h.set('DefaultFilePath', 'C:\ExcelWork', ...  
      'UserName', 'H. Hoover');
```

Properties That Take Arguments

Some COM objects have properties that behave somewhat like methods in that they accept input arguments. On a `get` or `set` operation, the value they end up getting or setting depends on the arguments you pass in.

The `Activesheet` interface of a Microsoft Excel application running as a COM server is one example. This interface has a property called `Range`, which is actually another interface. In order to get the correct `Range` interface, you must pass in specific range coordinates.

The first line of code shown here (taken from the example in “Using MATLAB as an Automation Client” on page 8-61) returns a specific `Range` interface. Arguments `A1` and `B2` specify which rectangular region of the spreadsheet to get the interface for:

```
eActivesheetRange = e.Activesheet.get('Range', 'A1', 'B2')  
eActivesheetRange =  
    Interface.Microsoft_Excel_5.0_Object_Library.Range
```

To get or set this type of property, use the `get` or `set` function as shown above for the `Range` property. Enter the input arguments in the parentheses following the property name:

```
handle.get(propertyname, arg1, arg2, ...);
```

In some ways, MATLAB handles these properties internally as though they were actually methods. The most important difference is that you need to use `invoke`, not `get`, to view the property:

```
e.ActiveSheet.invoke
    :
    Range = handle Range(handle, Variant, Variant(Optional))
    :
```

Get and Set on a Vector of Objects

You can use the `get` and `set` functions on more than one object at a time by putting the object handles into a vector and then operating on the vector.

This example creates a vector of handles to four Microsoft Calendar objects. It then modifies the `Day` property of all the objects in one operation by invoking `set` on the vector:

```
h1 = actxcontrol('mscal.calendar', [0 200 250 200]);
h2 = actxcontrol('mscal.calendar', [250 200 250 200]);
h3 = actxcontrol('mscal.calendar', [0 0 250 200]);
h4 = actxcontrol('mscal.calendar', [250 0 250 200]);
H = [h1 h2 h3 h4];

H.set('Day', 23)
H.get('Day')
ans =
    [23]
    [23]
    [23]
    [23]
```

Note To get or set values for multiple objects, you must use the `get` and `set` functions explicitly. Syntax like `H.Day` is only supported for scalar objects.

Using Enumerated Values for Properties

Enumeration makes examining and changing properties easier because each possible value for the property is given a string to represent it. For example, one of the values for the `DefaultSaveFormat` property in an Excel application is `x1UnicodeText`. This is much easier to remember than a numeric value like 57.

Finding All Enumerated Properties. The MATLAB COM get and set functions support enumerated values for properties for those applications that provide them. To see which properties use enumerated types, use the `set` function with just the object handle argument:

```
h = actxserver('excel.application');

h.set
ans =

                Creator: {'x1CreatorCode'}
    ConstrainNumeric: {}
CopyObjectsWithCells: {}
                Cursor: {4x1 cell}
            CutCopyMode: {2x1 cell}
                .
                .
```

MATLAB displays the properties that accept enumerated types as nonempty cell arrays. Properties for which there is a choice of settings are displayed as a multirow cell array, with one row per setting (see `Cursor` in the example above). Properties for which there is only one possible setting are displayed as a one row cell array (see `Creator`, above).

To display the current values of these properties, use `get` with just the object handle argument:

```
h.get

                Creator: 'x1CreatorCode'
    ConstrainNumeric: 0
CopyObjectsWithCells: 1
                Cursor: 'x1Default'
            CutCopyMode: ''
                .
                .
```

Setting an Enumerated Value. To list all possible enumerated values for a specific property, use `set` with the property name argument. The output is a cell array of strings, one string for each possible setting of the specified property:

```
h.set('Cursor')
ans =
    'xlIBeam'
    'xlDefault'
    'xlNorthwestArrow'
    'xlWait'
```

To set the value of a property to an enumerated type, simply assign the enumerated value to the property name:

```
handle.property = 'enumeratedvalue';
```

You can also use the `set` function with the property name and enumerated value:

```
handle.set('property', 'enumeratedvalue');
```

You have a choice of using the enumeration or its equivalent numeric value. You can abbreviate the enumeration string, as in the third line shown below, as long as you use enough letters in the string to make it unambiguous. Enumeration strings are also case insensitive.

Make the Excel spreadsheet window visible and then change the cursor from the MATLAB client. To see how the cursor has changed, you need to click on the spreadsheet window. Either of the following assignments to `h.Cursor` sets the cursor to the Wait (hourglass) type:

```
h.Visible = 1;

h.Cursor = 'xlWait'
h.Cursor = 'xlw'           % Abbreviated form of xlWait
```

Read the value of the `Cursor` property you have just set:

```
h.Cursor
ans =
    xlWait
```

Using the Property Inspector

MATLAB also provides a graphical user interface to display and modify properties. You can open the Property Inspector by either of these two methods:

- Invoke the `inspect` function from the MATLAB command line
- Double-click on the object in the MATLAB Workspace browser

Create a server object running Microsoft Excel, and then set the object's `DefaultFilePath` property to `'C:\ExcelWork'`:

```
h = actxserver('excel.application');  
h.DefaultFilePath = 'C:\ExcelWork';
```

Now call the `inspect` function to display a new window showing the server object's properties:

```
h.inspect
```

Scroll down until you see the `DefaultFilePath` property that you just changed. It should read `C:\ExcelWork`.

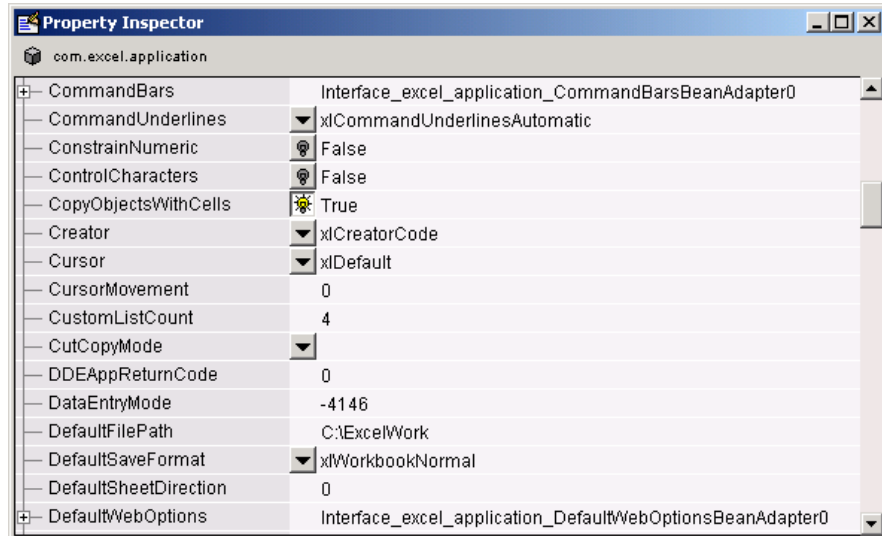

Using the Property Inspector, change `DefaultFilePath` once more, this time to `C:\MyWorkDirectory`. To do this, click on the property name at the left and then enter the new value at the right.

Now go back to the MATLAB Command Window and confirm that the `DefaultFilePath` property has changed as expected:

```
h.DefaultFilePath
ans =
    C:\MyWorkDirectory
```

Note If you modify properties at the MATLAB command line, you must refresh the **Property Inspector** window to see the change reflected there. Refresh the **Property Inspector** window by reinvoking `inspect` on the object.

Using the Property Inspector on Enumerated Values. Properties that accept enumerated values are marked by a  button in the **Property Inspector** window. The window shown below displays four enumerated values for the `Cursor` property. The current value will be indicated by a check mark.

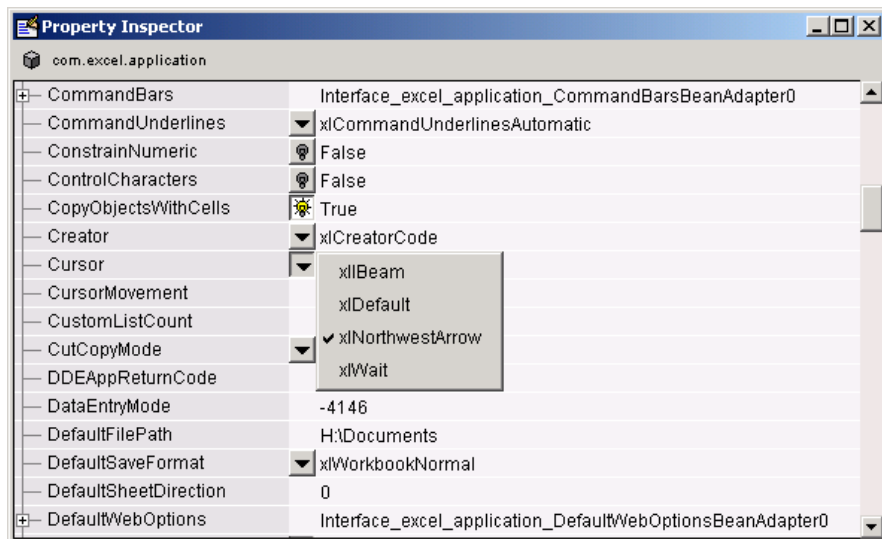

To change a property's value using the Property Inspector, simply click on the  button to display the options for that property, and then click on the desired value.

Custom Properties

You can attach your own properties to a control using the `addproperty` function. The syntax shown here creates a custom property for control, `h`:

```
h.addproperty('propertyName')
```

This example creates the `mwsamp2` control, adds a new property called `Position` to it, and assigns the value `[200 120]` to that property:

```
h = actxcontrol('mwsamp.mwsampctr1.2', [200 120 200 200]);  
h.addproperty('Position');  
h.Position = [200 120];
```

Use `get` to list all properties of control, `h`. You see that the new `Position` property has been added:

```
h.get  
ans =  
    Label: 'Label'  
    Radius: 20  
    Position: [200 120]  
  
h.Position  
ans =  
    200    120
```

To remove custom properties from a control, use `deleteproperty` with the following syntax:

```
h.deleteproperty('propertyName')
```

For example, delete the `Position` property that you just created, and use `get` to show that it no longer exists:

```
h.deleteproperty('Position');  
  
h.get  
    Label: 'Label'  
    Radius: 20
```

Control and Server Events

An *event* is typically some type of user-initiated action that takes place in a server application and often requires some type of reaction from the client. For example, a user clicking the mouse at a particular location in a server interface window might require that the client take some action in response. When an event is *fired*, the server communicates this occurrence to the client. If the client is *listening* to this particular type of event, it responds by executing a routine called an event handler.

The MATLAB client can listen to and respond to events fired by an ActiveX control or COM Automation server. You select which events you want the client to listen to by registering each event you want active along with the event handler to be used in responding to the event. When any registered event takes place in the control or server, the client is notified and responds by executing the appropriate handler routine. Event handlers in MATLAB are often implemented using M-files.

This section covers the following topics on registering and responding to events fired from an ActiveX control or Automation server:

- “Functions for Working with Events” on page 8-43
- “How to Prepare for and Handle Events from a COM Server” on page 8-44
- “Example — Responding to Events from an ActiveX Control” on page 8-46
- “Example — Responding to Events from an Automation Server” on page 8-49

Functions for Working with Events

Use these MATLAB functions to register and unregister events, to list all events, or to list just registered events for a control or server.

Function	Description
<code>actxcontrol</code>	Create a COM control and optionally register those events you want the client to listen to
<code>eventlisteners</code>	Return a list of events attached to listeners
<code>events</code>	List all events, both registered and unregistered, a control or server can generate
<code>isevent</code>	Determine if an item is an event of a COM object

Function	Description
registerevent	Register an event handler with a control or server event
unregisterallevnts	Unregister all events for a control or server
unregisterevent	Unregister an event handler with a control or server event

When using these functions, enter event names and event handler names as strings or in a cell array of strings. These names are case insensitive, but cannot be abbreviated.

How to Prepare for and Handle Events from a COM Server

This section describes the basic steps you need to take in handling events fired by a COM control or server:

- “Registering Those Events You Want to Respond To” on page 8-44
- “Identifying All Events and Registered Events” on page 8-45
- “Responding to Events As They Occur” on page 8-45
- “Unregistering Events You No Longer Want to Listen To” on page 8-45

Registering Those Events You Want to Respond To. Use the `registerevent` function to register those server events you want the client to respond to. There are two ways you can register events:

- If you have one function that handles all types of server events, you can register this common event handler to respond to all events fired by that server using the syntax

```
h.registerevent('handler');
```

- If you have a separate event handler function for different types of events, you can register each event with its corresponding handler using the syntax

```
h.registerevent({'event1' 'handler1'; 'event2' 'handler2'; ...});
```

For ActiveX controls, you can also register events at the time you create the control using the `actxcontrol` function. This function returns a handle `h` to the newly created control object:

- To register a common event handler function to respond to all events, use

```
h = actxcontrol('progid', position, figure, 'handler');
```

- To register a separate function to handle each type of event, use

```
h = actxcontrol('progid', position, figure, ...  
    {'event1' 'handler1'; 'event2' 'handler2'; ...});
```

The MATLAB client only listens to those events that you have registered.

Identifying All Events and Registered Events. Use the `events` function to list all events the control or server is capable of responding to. This function returns a structure array, where each field of the structure is the name of an event handler and the value of that field contains the signature for the handler routine. To invoke events on an object with handle `h`, type

```
S = h.events
```

The `eventlisteners` function lists only those events that are currently registered. This function returns a cell array, with each row representing a registered event and the name of its event handler. To invoke `eventlisteners` on an object with handle `h`, type

```
C = h.eventlisteners
```

Responding to Events As They Occur. Whenever a control or server fires an event that the client is listening to, the client responds to the event by invoking one or more event handlers that have been registered for that event. You can implement these routines in M-file programs that you write to handle events. Read more about event handlers in the section on “Writing Event Handlers” on page 8-52.

Unregistering Events You No Longer Want to Listen To. If you have registered events that you now want the client to ignore, you can unregister them at any time using the functions `unregisterevent` and `unregisterallevents` as shown here:

- For a server with handle `h`, to unregister all events registered with a common event handling function handler, use

```
h.unregisterevent('handler');
```

- To unregister individual events eventN, each registered with its own event handling function handlerN, use

```
h.unregisterevent({'event1' 'handler1'; 'eventN' 'handlerN'});
```

- To unregister all events from the server regardless of which event handling function they are registered with, use

```
h.unregisterallevents;
```

Example — Responding to Events from an ActiveX Control

This example shows how to handle events fired by an ActiveX control. It uses a control called `mwsamp2` that ships with MATLAB. The event handler routines for `mwsamp2` are defined when you install MATLAB.

Parts of the example are

- “Registering Control Events” on page 8-46
- “Listing Control Events” on page 8-47
- “Responding to Control Events” on page 8-47
- “Unregistering Control Events” on page 8-48

Registering Control Events. The `actxcontrol` function not only creates the control object, but can be used to register specific events as well. The code shown here registers two events (`Click` and `MouseDown`) and two respective handler routines (`myclick` and `mymoused`) with the `mwsamp2` control.

```
f = figure('position', [100 200 200 200]);
h = actxcontrol('mwsamp.mwsampctr1.2', [0 0 200 200], f, ...
    {'Click' 'myclick'; 'MouseDown' 'mymoused'});
```

If, at some later time, you want to register additional events, use the `registerevent` function:

```
h.registerevent({'Db1Click' 'my2click'});
```

You can view the event handler code written for the `mwsamp2` control in the section “Sample Event Handlers” on page 8-55.

Unregister the `Db1Click` event before continuing with the example:

```
h.unregisterevent({'Db1Click' 'my2click'});
```

Listing Control Events. At this point, only the Click and MouseDown events should be registered. To see all events that the control can fire, use the `events` function. This function returns a structure array, where each field of the structure is the name of an event handler and the value of that field contains the signature for the handler routine.

To list all events, whether registered or not, use

```
S = h.events
S =
    Click: 'void Click()'
    DblClick: 'void DblClick()'
    MouseDown: 'void MouseDown(int16 Button, int16 Shift,
        Variant x, Variant y)'
```

```
S.Event_Args
ans =
    void Event_Args(int16 typeshort, int32 typelong,
        double typedouble, string typestring, bool typebool)
```

To list only those events that are currently registered with the control, use the `eventlisteners` function. This function returns a cell array, with each row representing a registered event and the name of its event handler.

Use `eventlisteners` to list registered event names and their handler routines:

```
h.eventlisteners
ans =
    'click'          'myclick'
    'mousedown'     'mymoused'
```

Responding to Control Events. When MATLAB creates the `mwsamp2` control, it also displays a figure window showing a label and circle at the center. If you click on different positions in this window, you see a report in the MATLAB Command Window of the X and Y position of the mouse.

Each time you press the mouse button, the MouseDown event fires, calling the `mymoused` function. This function prints the position values for that event to the MATLAB Command Window:

```
The X position is:  
ans =  
    [122]  
The Y position is:  
ans =  
    [63]
```

You also see the following line reported in response to the Click event:

```
Single click function
```

Double-clicking the mouse does nothing different, since the `Db1Click` event has been unregistered.

Unregistering Control Events. When you unregister an event, the client discontinues listening for occurrences of that event. When the event fires, the client does not respond. If you unregister the `MouseDown` event, you will notice that MATLAB no longer reports the X and Y position when you click in the window:

```
h.unregisterevent({'MouseDown' 'mymoused'});
```

Now, register the `Db1Click` event, connecting it with handler function `my2click`:

```
h.registerevent({'Db1Click', 'my2click'});
```

If you call `eventlisteners` again, you will see that the registered events are now `Click` and `Db1Click`:

```
h.eventlisteners  
ans =  
    'click'      'myclick'  
    'dblclick'  'my2click'
```

When you double-click the mouse button, MATLAB responds to both the `Click` and `Db1Click` events by displaying the following in the MATLAB Command Window:

```
Single click function  
Double click function
```

An easy way to unregister all events for a control is to use the `unregisterallevents` function. When there are no events registered, `eventlisteners` returns an empty cell array:

```
h.unregisterallevents

h.eventlisteners
ans =
    {}
```

Clicking the mouse in the control window now does nothing since there are no active events.

If you have events that are registered with a common event handling routine, such as `sampev.m` used in the example below, you can use `unregisterevent` to unregister all of these events in one operation. The example that follows first registers all events from the server with a common handling routine `sampev`. MATLAB now handles any type of event from this server by executing `sampev`:

```
h.registerevent('sampev');
```

Verify the registration by listing all event listeners for that server:

```
h.eventlisteners
ans =
    'click'          'sampev'
    'dblclick'       'sampev'
    'mousedown'     'sampev'
```

Now unregister all events for the server that use the `sampev` event handling routine:

```
h.unregisterevent('sampev');
h.eventlisteners
ans =
    {}
```

Example — Responding to Events from an Automation Server

The next example shows how to handle events fired by an Automation server. It creates a server running Internet Explorer, registers a common handler for all events, and then has you fire events by browsing to Web sites using the Internet Explorer application.

Parts of the example are

- “Registering Server Events” on page 8-50
- “Listing Server Events” on page 8-51
- “Responding to Server Events” on page 8-51
- “Unregistering Server Events” on page 8-52
- “Closing the Application” on page 8-52

Registering Server Events. This example registers all events fired by an Automation server and, unlike the example above, registers the same handler routine, `serverevents`, to respond to all types of events. Since this example does not ship with MATLAB, you will have to create the event handler routine yourself. Create the file `serverevents.m`, inserting this code:

```
function serverevents(varargin)

% Display incoming event name
eventname = varargin{end}

% Display incoming event args
eventargs = varargin{end-1}
```

Next, in your MATLAB session, use the following commands to create your Automation server application and register this handler routine for all events from the server:

```
% Create a server running Internet Explorer.
h = actxserver('internetexplorer.application');

% Make the server application visible.
h.set('Visible', 1);

% Register all events from the server with a common event
% handler routine.
h.registerevent('serverevents');
```

Listing Server Events. Use the `events` function to list all events the control or server is capable of responding to, and `eventlisteners` to list only those events that are currently registered:

```
h = actxserver('internetexplorer.application');
h.Visible = 1;

h.events
  StatusTextChanged = void StatusTextChanged(string Text)
  ProgressChange = void ProgressChange(int32 Progress,
    int32 ProgressMax)
  CommandStateChange = void CommandStateChange(int32 Command,
    bool Enable)
    :
    :

% No events are registered at this time, so eventlisteners
% returns an empty cell array.
h.eventlisteners
ans =
    {}

h.registerevent('serverevents');
h.eventlisteners
ans =
    'statustextchange'    'serverevents'
    'progresschange'    'serverevents'
    'commandstatechange' 'serverevents'
    :
    :
```

Responding to Server Events. At this point, all events have been registered. If any event fires, the common handler routine defined in `serverevents.m` executes to handle that event. Use the Internet Explorer application to browse your favorite Web site, or enter the following command in the MATLAB Command Window:

```
h.Navigate2('http://www.mathworks.com');
```

You should see a long series of events displayed in your client window.

Unregistering Server Events. Use the `unregisterevent` function to remove specific events from the registry. Specify each event that you want unregistered along with its handler function in a cell array of strings:

```
h.unregisterevent({'event1', 'handler1'; ...  
                  'event2', 'handler2', ...});
```

If the events were registered with a common handler, as in this example, specify the name of the common routine with each event that you want removed from the event registry for that object:

```
h.unregisterevent({'event1', 'commonhandler'; ...  
                  'event2', 'commonhandler', ...});
```

Continuing with this example, unregister the `progresschange` and `commandstatechange` events:

```
h.unregisterevent({'progresschange', 'serverevents'; ...  
                  'commandstatechange', 'serverevents'});
```

To unregister all events for an object, use `unregisterallevents`. These two commands unregister all the events that had been registered for the Internet Explorer application and then registers only a single event:

```
h.unregisterallevents;  
h.registerevent({'TitleChange', 'serverevents'});
```

If you now browse with Internet Explorer, MATLAB only responds to the `TitleChange` event.

Closing the Application. It is always advisable to close a server application when you no longer intend to use it. You can unregister all events and close the application used in this example by typing

```
h.unregisterallevents;  
h.Quit;  
h.delete;
```

Writing Event Handlers

This section covers the following topics on writing handler routines to respond to events fired from an ActiveX control or Automation server:

- “Overview of Event Handling” on page 8-53

- “Arguments Passed to Event Handlers” on page 8-54
- “Event Structure” on page 8-55
- “Sample Event Handlers” on page 8-55
- “Writing Event Handlers Using M-File Subfunctions” on page 8-57

Overview of Event Handling

An event is fired when a control or server wants to notify its client that something of interest has occurred. For example, many controls trigger an event when the user clicks somewhere in the interface window of a control. In MATLAB, you can create and register your own M-file functions so that they respond to events when they occur. These functions serve as event handlers. You can create one handler function to handle all events or a separate handler for each type of event.

For controls, you can register your handler functions either at the time you create the control (using `actxcontrol`), or at any time afterwards (using `registerevent`). For servers, you must use the `registerevent` function to register those events you want the client to listen to. Specify the event handler in the argument list, as shown below for `actxcontrol`. The event handler argument can be either the name of a single callback routine or a cell array that associates specific events with their respective event handlers:

```
h = actxcontrol (progid, position, handle, ...
  callback | {event1 eventhandler1; event2 eventhandler2; ...})
```

When you specify the single callback routine, MATLAB registers all events with that one routine. When any event is fired, MATLAB executes the common callback routine.

You can list all the events that a COM object recognizes using the `events` function. For example, to list all events for the `mwsamp2` control, use

```
f = figure ('position', [100 200 200 200]);
h = actxcontrol ('mwsamp.mwsampctrl.2', [0 0 200 200], f);

h.events
Click = void Click()
DblClick = void DblClick()
MouseDown = void MouseDown(int16 Button, int16 Shift,
  Variant x, Variant y)
```

Arguments Passed to Event Handlers

When a registered event is triggered, MATLAB passes information from the event to its handler function as shown in this table.

Arguments Passed by MATLAB

Arg. No.	Contents	Format
1	Object Name	MATLAB COM class
2	Event ID	double
3	Start of Event Arg. List	As passed by the control
end-2	End of Event Arg. List (Arg. N)	As passed by the control
end-1	Event Structure	structure
end	Event Name	char array

When writing an event handler function, use the Event Name argument to identify the source of the event. Get the arguments passed by the control from the Event Argument List (arguments 3 through end-2). All event handlers must accept a variable number of arguments:

```
function event (varargin)
if (varargin{end}) == 'MouseDown'           % Check the event name
    x_pos = varargin{5};                     % Read 5th Event Argument
    y_pos = varargin{6};                     % Read 6th Event Argument
end
```

Note The values passed vary with the particular event and control being used.

Event Structure

The second to last argument passed by MATLAB is the Event Structure, which has the following fields.

Fields of the Event Structure

Field Name	Description	Format
Type	Event Name	char array
Source	Control Name	MATLAB COM class
EventID	Event Identifier	double
Event Arg Name 1	Event Arg Value 1	As passed by the control
Event Arg Name 2	Event Arg Value 2	As passed by the control
etc.	Event Arg N	As passed by the control

For example, when the MouseDown event of the mwsamp2 control is triggered, MATLAB passes this Event Structure to the registered event handler:

```
Type: 'MouseDown'
Source: [1x1 COM.mwsamp.mwsampctrl1.2]
EventID: -605
Button: 1
Shift: 0
      x: 27
      y: 24
```

Sample Event Handlers

Specify a single callback, sampev:

```
f = figure('position', [100 200 200 200]);
h = actxcontrol('mwsamp.mwsampctrl1.2', [0 0 200 200], ...
   (gcf, 'sampev')
h =
    COM.mwsamp.mwsampctrl1.2
```

Or specify several events using the cell array format:

```
h = actxcontrol('mwsamp.mwsampctr1.2', [0 0 200 200], f, ...
    {'Click' 'myclick'; 'Db1Click' 'my2click'; ...
    'MouseDown' 'mymoused'});
```

The event handlers, myclick.m, my2click.m, and mymoused.m, are

```
function myclick(varargin)
disp('Single click function')

function my2click(varargin)
disp('Double click function')

function mymoused(varargin)
disp('You have reached the mouse down function')
disp('The X position is: ')
double(varargin{6})
disp('The Y position is: ')
double(varargin{7})
```

Alternatively, you can use the same event handler for all the events you want to monitor using the cell array pairs. Response time will be better than using the callback style.

For example

```
f = figure('position', [100 200 200 200]);
h = actxcontrol('mwsamp.mwsampctr1.2', ...
    [0 0 200 200], f, {'Click' 'allevents'; ...
    'Db1Click' 'allevents'; 'MouseDown' 'allevents'})
```

where allevents.m is

```
function allevents(varargin)
if (strcmp(varargin{3}.Type, 'Click'))
    disp ('Single Click Event Fired')
elseif (strcmp(varargin{3}.Type, 'Db1Click'))
    disp ('Double Click Event Fired')
elseif (strcmp(varargin{3}.Type, 'MouseDown'))
    disp ('Mousedown Event Fired')
end
```

Writing Event Handlers Using M-File Subfunctions

Instead of having to maintain a separate M-file for every event handler routine you write, you can consolidate some or all of these routines into a single M-file using M-file subfunctions.

This example shows three event handler routines, (`myclick`, `my2click`, and `mymoused`) implemented as subfunctions in the file `mycallbacks.m`. The call to `str2func` converts the input string to a function handle:

```
function a = mycallbacks(str)
    a = str2func(str);

function myclick(varargin)
    disp('Single click function')

function my2click(varargin)
    disp('Double click function')

function mymoused(varargin)
    disp('You have reached the mouse down function')
    disp('The X position is: ')
    double(varargin{6})
    disp('The Y position is: ')
    double(varargin{7})
```

To register one of these events, you just call `mycallbacks`, passing the name of the event handler:

```
h = actxcontrol('mwsamp.mwsampctrl1.2', [0 0 200 200], ...
    gcf, 'sampev')
h.registerevent('Click', mycallbacks('myclick'));
```

Saving Your Work

Use these MATLAB functions to save and restore the state of a COM control object.

Function	Description
load	Load and initialize a COM control object from a file
save	Write and serialize a COM control object to a file

Save the current state of a COM control to a file using the save function. The following example creates an mwsamp2 control and saves its original state to the file mwsample:

```
f = figure('position', [100 200 200 200]);  
h = actxcontrol('mwsamp.mwsampctrl1.2', [0 0 200 200], f);  
h.save('mwsample')
```

Now, alter the figure by changing its label and the radius of the circle:

```
h.Label = 'Circle';  
h.Radius = 50;  
h.Redraw;
```

Using the load function, you can restore the control to its original state:

```
h.load('mwsample');  
h.get  
ans =  
    Label: 'Label'  
    Radius: 20
```

Note The COM save and load functions are only supported for controls at this time.

Releasing COM Interfaces and Objects

Use these MATLAB functions to release or delete a COM object or interface.

Function	Description
<code>delete</code>	Delete a COM object or interface
<code>release</code>	Release a COM object or interface

When each interface is no longer needed, use the `release` function to release the interface and reclaim the memory used by it. When the entire control or server is no longer needed, use the `delete` function to delete it. Alternatively, you can use the `delete` function on any valid interface. All interfaces for that object are automatically released and the server or control itself is deleted.

Note In versions of MATLAB earlier than 6.5, failure to explicitly release interface handles or delete the control or server often results in a memory leak. This is true even if the variable representing the interface or COM object has been reassigned. In MATLAB 6.5 and later, the control or server, along with all interfaces to it, is destroyed on reassignment of the variable or when the variable representing a COM object or interface goes out of scope.

MATLAB automatically releases all interfaces for a control when the figure window that contains that control is deleted or closed. MATLAB also automatically releases all handles for an Automation server when MATLAB is shut down.

Identifying Objects

Use these MATLAB functions to get information about a COM object.

Function	Description
<code>class</code>	Return the class of a COM object
<code>isa</code>	Detect a COM object of a given class

Function	Description
isevent	Determine if an item is an event of a COM object
ismethod	Determine if an item is a method of a COM object
isprop	Determine if an item is a property of a COM object

Create a COM object, *h*, in an Automation server running Excel, and also a Workbooks interface, *w*, to the object:

```
h = actxserver('excel.application');
w = h.Workbooks;
```

To find out the class of variable *w*, use the class function:

```
w.class
ans =
    Interface.Microsoft_Excel_9.0_Object_Library.Workbooks
```

To test a variable against a known class name, use isa:

```
h.isa('COM.excel.application')
ans =
    1
```

To see if UsableWidth is a property of object *h*, use isprop:

```
h.isprop('UsableWidth')
ans =
    1
```

To see if SaveWorkspace is a method of object *h*, use ismethod. Method names are case sensitive and cannot be abbreviated:

```
h.ismethod('SaveWorkspace')
ans =
    1
```

Create the sample *mwsamp2* control that comes with MATLAB, and use isevent to see if Db1Click is one of the events that this control recognizes:

```
f = figure('position', [100 200 200 200]);
h = actxcontrol('mwsamp.mwsampctrl.2', [0 0 200 200], f);
```

```
h.isevent('Db1Click')
ans =
     1
```

Examples of MATLAB as an Automation Client

This section provides examples of using MATLAB as an Automation client with controls and servers:

- “MATLAB Sample Control” on page 8-61
- “Using MATLAB as an Automation Client” on page 8-61
- “Connecting to an Existing Excel Application” on page 8-63
- “Running a Macro in an Excel Server Application” on page 8-64

MATLAB Sample Control

MATLAB ships with a simple example COM control that draws a circle on the screen, displays some text, and fires events when the user single- or double-clicks on the control. Create the control by running the `mwsamp.m` file in the directory, `winfun\comcli`, or type

```
h = actxcontrol('mwsamp.mwsampctr1.2', [0 0 300 300]);
```

This control is stored in the MATLAB `bin`, or `executable`, directory along with the control's *type library*. The type library is a binary file used by COM tools to decipher the control's capabilities. See the section “Writing Event Handlers” on page 8-52 for other examples that use the `mwsamp2` control.

Using MATLAB as an Automation Client

This example uses MATLAB as an Automation client and Microsoft Excel as the server. It provides a good overview of typical functions. In addition, it is a good example of using the Automation interface of another application:

```
% MATLAB Automation client example
%
% Open Excel, add workbook, change active worksheet,
% get/put array, save.

% First, open an Excel Server.
e = actxserver('excel.application');
```

```
% Insert a new workbook.
eWorkbook = e.Workbooks.Add;
e.Visible = 1;

% Make the first sheet active.
eSheets = e.ActiveWorkbook.Sheets;

eSheet1 = eSheets.get('Item', 1);
eSheet1.Activate;

% Put a MATLAB array into Excel.
A = [1 2; 3 4];
eActivesheetRange = e.Activesheet.get('Range', 'A1:B2');
eActivesheetRange.Value = A;

% Get back a range. It will be a cell array, since the cell range
% can contain different types of data.
eRange = e.Activesheet.get('Range', 'A1:B2');
B = eRange.Value;

% Convert to a double matrix. The cell array must contain only
% scalars.
B = reshape([B{:}], size(B));

% Now, save the workbook.
eWorkbook.SaveAs('myfile.xls');

% To avoid saving the workbook and being prompted to do so,
% uncomment the following code.
% eWorkbook.Saved = 1;
% eWorkbook.Close;

% Quit Excel and delete the server.
% e.Quit;
% e.delete;
```

Note Make sure that you always close any workbooks that you add in Excel. This can prevent potential memory leaks.

Connecting to an Existing Excel Application

You can give MATLAB access to a file that is open by another application by creating a new COM server from the MATLAB client, and then opening the file through this server. This example shows how to do this for an Excel application that has a file `weekly_log.xls` open:

```
excelapp = actxserver('Excel.Application');
wkbk = excelapp.Workbooks;
wdata = wkbk.Open('d:\weatherlog\weekly_log.xls');
```

To see what methods you have available to you, type

```
wdata.methods
Methods for class Interface.Microsoft_Excel_10.0_
Object_Library._Workbook:

AcceptAllChanges    LinkInfo            ReloadAs
Activate            LinkSources         RemoveUser
:                   :                   :
:                   :                   :
```

Access data from the spreadsheet by selecting a particular sheet (called 'Week 12' in the example), selecting the range of values (the rectangular area defined by D1 and F6 here), and then reading from this range:

```
sheets = wdata.Sheets;
sheet12 = sheets.Item('Week 12');
range = sheet12.get('Range', 'D1', 'F6');
range.value

ans =
    'Temp.'    'Heat Index'    'Wind Chill'
    [78.4200]  [    32]        [    37]
    [69.7300]  [    27]        [    30]
    [77.6500]  [    17]        [    16]
    [74.2500]  [    -5]        [     0]
```

```
[ 68.1900] [ 22] [ 35]
```

```
wkbk.Close;
excelapp.Quit;
```

Running a Macro in an Excel Server Application

In the example below, MATLAB runs Microsoft Excel in a COM server and invokes a macro that has been defined within the active Excel spreadsheet file. The macro, `init_last`, takes no input parameters and is called from the MATLAB client using the statement

```
handle.ExecuteExcel4Macro('!macroname()');
```

Start the example by opening the spreadsheet file and recording a macro. The macro used here simply sets all items in the last column to zero. Save your changes to the spreadsheet.

Next, in MATLAB, create a COM server running an Excel application, and open the spreadsheet:

```
h = actxserver('Excel.Application');
wkbk = h.Workbooks;
file = wkbk.Open('d:\weatherlog\weekly.xls');
```

Open the sheet that you want to change, and retrieve the current values in the range of interest:

```
sheets = file.Sheets;
sheet12 = sheets.Item('Week 12');
range = sheet12.get('Range', 'D1', 'F5');
range.Value
ans =
    [ 78] [ 32] [ 37]
    [ 69] [ 27] [ 30]
    [ 77] [ 17] [ 16]
    [ 74] [ -5] [ -1]
    [ 68] [ 22] [ 35]
```

Now execute the macro, and verify that the values have changed as expected:

```
h.ExecuteExcel4Macro('!init_last()');
range.Value
ans =
```

[78]	[32]	[0]
[69]	[27]	[0]
[77]	[17]	[0]
[74]	[-5]	[0]
[68]	[22]	[0]

Additional COM Client Information

Using COM Collections

COM *collections* are a way to support groups of related COM objects that can be iterated over. A collection is itself a special interface with a `Count` property (read only), which contains the number of items in the collection, and an `Item` method, which allows you to retrieve a single item from the collection.

The `Item` method is indexed, which means that it requires an argument that specifies which item in the collection is being requested. The data type of the index can be any data type that is appropriate for the particular collection and is specific to the control or server that supports the collection. Although integer indices are common, the index could just as easily be a string value. Often, the return value from the `Item` method is itself an interface. Like all interfaces, this interface should be released when you are finished with it.

This example iterates through the members of a collection. Each member of the collection is itself an interface (called `Plot` and represented by a MATLAB COM object called `hPlot`.) In particular, this example iterates through a collection of `Plot` interfaces, invokes the `Redraw` method for each interface, and then releases each interface:

```
hCollection = hControl.Plots;
for i = 1:hCollection.Count
    hPlot = hCollection.invoke('Item', i);
    hPlot.Redraw;
    hPlot.release;
end;
hCollection.release;
```

Converting Data

Since COM defines a number of different data formats and types, you will need to know how MATLAB converts data from COM objects into variables in the MATLAB workspace. Data from COM objects must be converted:

- When a property value is retrieved
- When a value is returned from a method invocation

This chart shows how COM data types are converted into variables in the MATLAB workspace.

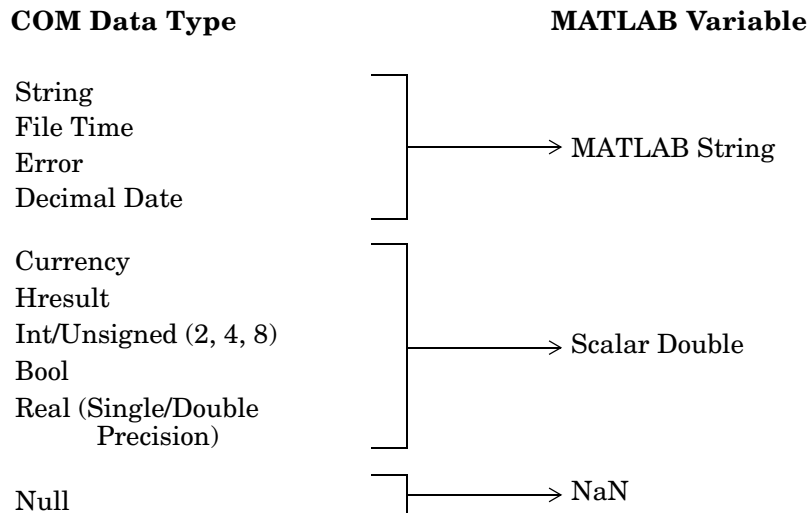

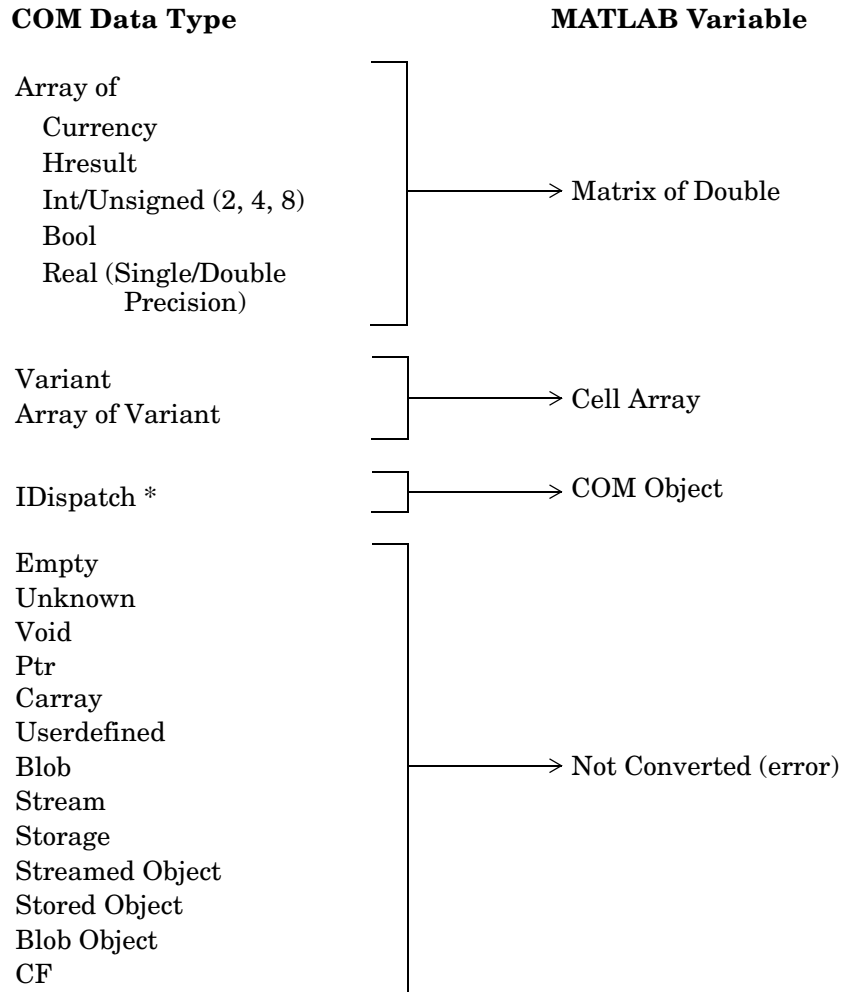

Using MATLAB as a DCOM Client

Distributed Component Object Model (DCOM) is a protocol that allows clients to use remote COM objects over a network. Additionally, MATLAB can be used as a DCOM client with remote Automation servers if the operating system on which MATLAB is running is DCOM enabled.

Note If you use MATLAB as a remote DCOM server, all MATLAB windows will appear on the remote machine.

MATLAB COM Support Limitations

The following is a list of limitations of MATLAB COM support:

- MATLAB only supports indexed collections.
- COM controls are not printed with figure windows.
- MATLAB supports events from controls only, not from servers.

MATLAB Automation Server Support

MATLAB on Microsoft Windows supports COM Automation server capabilities. Automation is a COM protocol that allows one application or component (the *controller*) to control another application or component (the *server*). Thus, a MATLAB server can be controlled by any Windows program that can be an Automation controller. Some examples of applications that can be Automation controllers are Microsoft Excel, Microsoft Access, Microsoft Project, and many Visual Basic and Visual C++ programs.

This section explains how to create and connect to an Automation server running MATLAB, how to call functions in the server from either MATLAB M-file or Visual Basic client applications, and how to use properties that affect the server:

- “Creating the Automation Server” on page 8-70
- “Connecting to an Existing Server” on page 8-71
- “Automation Server Functions” on page 8-72
- “Example — Running an M-File from Visual Basic” on page 8-76
- “Example — Viewing Methods from a Visual Basic 6.0 Client” on page 8-77
- “MATLAB Automation Properties” on page 8-77

Note If you plan to build your client application using either C or Fortran, we recommend that you use the MATLAB Engine facility instead of an Automation server.

Creating the Automation Server

Exactly how you create an Automation server depends on the controller you are using. Consult the documentation for your controller for this information. All controllers require a programmatic identifier (ProgID) to identify the server. The ProgID registered for MATLAB is `matlab.application`.

If your controller is a MATLAB application, you can create the Automation server using the MATLAB `actxserver` function:

```
h = actxserver('matlab.application')  
h =
```

COM.matlab.application

Usually, the Automation server is automatically created by Windows when the controller first establishes its connection to the server. You may also choose to create the server manually. See “Creating the Server Manually” on page 8-79.

Shared and Dedicated Servers

You can start a MATLAB Automation server in either of two modes:

- **Shared** — One or more client applications connect to the same MATLAB server. The server is shared between all clients.
- **Dedicated** — Each client application creates its own dedicated MATLAB server.

If you use `matlab.application` as your ProgID, MATLAB creates a shared server. See “Specifying a Shared or Dedicated Server” on page 8-79.

Startup Directory

The Automation server starts up in the `\bin\win32` subdirectory of your MATLAB root directory, (the directory returned by the `matlabroot` function). If this is not your usual MATLAB startup directory, then the newly created server may not have access to files in that directory and also will not run your MATLAB startup file (`startup.m`) when the server process starts MATLAB.

To give the server access to files in your startup directory, you need to either have the server set its working directory to the startup directory (using the `cd` function), add the startup directory to the server’s MATLAB path (using `addpath`), or include the pathname to the startup directory when referencing those files.

Connecting to an Existing Server

It is not always necessary to create a new instance of a MATLAB server whenever your application needs some task done within MATLAB. Clients can connect to an existing MATLAB automation server using a command similar to the Visual Basic `GetObject` command.

The Visual Basic command shown here returns a handle `h` to MATLAB server application:

```
h = GetObject(, "matlab.application")
```

Note It is important to use the syntax shown above to connect with an existing MATLAB automation server. Omit the first argument, and make sure that the second argument reads exactly as shown.

The sample Visual Basic code shown here connects to an existing MATLAB server, and then executes a plot command in the server. If you do not already have a MATLAB server running, then you can create one following the instructions in “Creating the Automation Server” on page 8-70.

Then, enter the following code in a Visual Basic program to connect to the server and have MATLAB draw a simple plot:

```
Dim h As Object
Set h = GetObject(, "matlab.application")

' Handle h should be valid now. Test it by calling Execute.
h.Execute ("plot([0 18], [7 23])")
```

Automation Server Functions

MATLAB provides a number of functions to enable an Automation controller written in either MATLAB or Visual Basic to manipulate data in the MATLAB server. These are shown in the tables below and are described in individual function reference pages.

- “Executing Commands in the MATLAB Server” on page 8-73
- “Exchanging Data with the Server” on page 8-74
- “Controlling the Server Window” on page 8-75
- “Terminating the Server Process” on page 8-75
- “Client-Specific Information” on page 8-75

For a description of how to use these functions in controller programs, see “COM Server Reference” in the External Interfaces reference documentation.

Executing Commands in the MATLAB Server

The client program can execute commands in the MATLAB server using these functions.

Function	Description
Execute	Execute MATLAB command in server
Feval	Evaluate MATLAB command in server

Use `Execute` when you want the MATLAB server to execute a command that can be expressed in a single string:

```
h = actxserver('matlab.application');

h.PutWorkspaceData('A', 'base', rand(6));
h.Execute('A(4:6,:) = [];');
B = h.GetWorkspaceData('A', 'base')
B =
    0.6208    0.2344    0.6273    0.3716    0.7764    0.7036
    0.7313    0.5488    0.6991    0.4253    0.4893    0.4850
    0.1939    0.9316    0.3972    0.5947    0.1859    0.1146
```

Use `Feval` when you want the server to execute a command that cannot be expressed in a single string. An example of this is the `Feval` command shown below that contains variables not defined in the server: `rows`, `cols`, and `pages`. (The expression `'A='` causes MATLAB to interpret `A` as a variable name).

This is a continuation of the example shown above:

```
rows = 3; cols = 3; pages = 2;
h.Feval('reshape', 1, {'A=', rows, cols, pages});

B = h.GetWorkspaceData('A', 'base')
B(:, :, 1) =
    0.6208    0.2344    0.6273
    0.7313    0.5488    0.6991
    0.1939    0.9316    0.3972
```

```
B(:, :, 2) =
    0.3716    0.7764    0.7036
    0.4253    0.4893    0.4850
    0.5947    0.1859    0.1146
```

Exchanging Data with the Server

MATLAB provides several functions to read and write data to any workspace of a MATLAB server. In each of these commands, you pass the name of the variable to read or write, and the name of the workspace holding that data.

Function	Description
GetCharArray	Get character array from server
GetFullMatrix	Get matrix from server
GetWorkspaceData	Get any type of data from server
PutCharArray	Store character array in server
PutFullMatrix	Store matrix in server
PutWorkspaceData	Store any type of data in server

The `Get/PutCharArray` functions read and write string values to the MATLAB server.

The `Get/PutFullMatrix` functions pass data as a `SAFEARRAY` data type. You can use these functions with any client that supports the `SAFEARRAY` type. This includes MATLAB and Visual Basic clients.

The `Get/PutWorkspaceData` functions pass data as a variant data type. Use these functions with any client that supports the variant type. These functions are especially useful for VBScript clients as VBScript does not support the `SAFEARRAY` data type.

Write a string to variable `str` in the base workspace of the MATLAB server and then read it back to the client:

```
h = actxserver('matlab.application');
h.PutCharArray('str', 'base', ...
    'He jests at scars that never felt a wound.');
```

```
S = h.GetCharArray('str', 'base')
S =
    He jests at scars that never felt a wound.
```

Controlling the Server Window

These functions enable you to make the server window visible or to minimize it.

Function	Description
MaximizeCommandWindow	Display server window on Windows desktop
MinimizeCommandWindow	Minimize size of server window

Create a COM server running MATLAB and minimize it:

```
h = actxserver('matlab.application');
h.MinimizeCommandWindow;
```

Terminating the Server Process

When you are finished with the MATLAB server, quit the MATLAB session and terminate the server process using the Quit function.

Function	Description
Quit	Terminate MATLAB server

To terminate the server process, enter

```
h.Quit;
```

Client-Specific Information

This section provides information that is specific to either a MATLAB or Visual Basic client.

For MATLAB Clients. To see a summary of all functions available to controller applications along with the required syntax, start a MATLAB Automation server, and then use the `invoke` function with only the `handle` argument:

```
handle = actxserver('matlab.application');  
handle.invoke
```

For Visual Basic Clients. Data types for the arguments and return values of the server functions are expressed as Automation data types, which are language-independent types defined by the Automation protocol. For example, BSTR is a wide-character string type defined as an Automation type, and is the same data format used by Visual Basic to store strings. Any COM-compliant controller should support these data types, although the details of how you declare and manipulate these are controller specific.

Example – Running an M-File from Visual Basic

This example calls an M-file function named `solve_bvp` from a Visual Basic client application through a COM interface. It also plots a graph in a new MATLAB window and performs a simple computation:

```
Dim MatLab As Object  
  
Private Sub Call_MFile()  
  
Dim Result As String  
Dim MReal(1, 3) As Double  
Dim MImag(1, 3) As Double  
  
Set MatLab = CreateObject("Matlab.Application")  
  
'CALLING M-FILE FROM VB  
Result = MatLab.Execute("cd d:\matlab\work\bvp")  
Result = MatLab.Execute("solve_bvp")  
  
'OTHER THINGS THAT CAN BE DONE  
Result = MatLab.Execute("surf(peaks)")  
Result = MatLab.Execute("a = [1 2 3 4; 5 6 7 8;]")  
Result = MatLab.Execute("b = a + a ")  
Call MatLab.GetFullMatrix("b", "base", MReal, MImag)  
  
End Sub
```

Example – Viewing Methods from a Visual Basic 6.0 Client

You can find out what methods are available from a MATLAB automation server using the Object Browser of your Visual Basic client application. To do this, follow this procedure in the client application to reference the MATLAB Application Type Library:

- 1 Select the **Project** menu
- 2 Select **Reference** from the subsequent menu
- 3 Check the box next to the **MATLAB Application Type Library**
- 4 Click **OK**

This enables you to view MATLAB automation methods from the Visual Basic Object Browser under the Library called MLAPP. You will now also be able to see a list of MATLAB automation methods when you use the term `Matlab` followed by a period. For example,

```
Dim Matlab As MApp.MApp
```

```
Private Sub View_Methods()  
Set Matlab = New MApp.MApp
```

```
'The next line should show a list of MATLAB Automation methods  
Matlab.
```

```
End Sub
```

MATLAB Automation Properties

You have the option of making your server application visible or not by setting the `Visible` property. When visible, the server window appears on the desktop, enabling the user to interact with the server application. This may be useful for such purposes as debugging. When not visible, the server window does not appear, thus perhaps making for a cleaner interface and also preventing any interaction with the server application.

By default, the `Visible` property is enabled, or set to 1:

```
h = actxserver('matlab.application');  
h.Visible  
ans =  
    1
```

You can change the setting of `Visible` by setting it to 0 (invisible) or 1 (visible). The following command removes the server application window from the desktop:

```
h.Visible = 0;  
  
h.Visible  
ans =  
    0
```

Additional Automation Server Information

This section covers several other topics related to Automation servers:

- “Creating the Server Manually” on page 8-79
- “Specifying a Shared or Dedicated Server” on page 8-79
- “Using MATLAB as a DCOM Server” on page 8-80

Creating the Server Manually

The Automation server is created automatically by Windows when a controller application first establishes a server connection. Alternatively, you may choose to create the server manually, prior to starting any of the client processes.

To do this, use the `/Automation` switch in the MATLAB startup command:

- 1 Right-click the MATLAB shortcut icon  and select **Properties** from the context menu. The **Properties** dialog box for `matlab.exe` opens to the **Shortcut** panel.
- 2 In the **Target** field, after the target path for `matlab.exe`, add `/Automation`.

Note When Windows automatically creates a MATLAB server, it too uses the `/Automation` switch. In this way, MATLAB servers are differentiated from other MATLAB sessions. This protects controllers from interfering with any interactive MATLAB sessions that may be running.

Specifying a Shared or Dedicated Server

You can start the MATLAB Automation server in one of two modes — shared or dedicated. A dedicated server is dedicated to a single client; a shared server is shared by multiple clients. The mode is determined by the programmatic identifier (ProgID) used by the client to start MATLAB.

Starting a Shared Server

The ProgID, `matlab.application`, specifies the default mode, which is shared. You can also use the version-specific ProgID, `matlab.application.N`, where `N` is equal to the major version of MATLAB you are running, (for example, `N = 6` for MATLAB 6.5).

Once MATLAB is started as a shared server, all clients that request a connection to MATLAB by using the shared server ProgID connect to the already running instance of MATLAB. In other words, there is never more than one instance of a shared server running, since it is shared by all clients that use the ProgID that specifies a shared server.

Starting a Dedicated Server

To specify a dedicated server, use the ProgID, `matlab.application.single`, (or the version-specific ProgID, `matlab.application.single.N`).

Each client that requests a connection to MATLAB using a dedicated ProgID creates a separate instance of MATLAB, and that server will not be shared with any other client. Therefore, there can be several instances of a dedicated server running simultaneously, since the dedicated server is not shared by multiple clients.

Using MATLAB as a DCOM Server

Distributed Component Object Model (DCOM) is a protocol that allows COM connections to be established over a network. If you are using a version of Windows that supports DCOM (Windows NT 4.0 at the time of this writing) and a controller that supports DCOM, you can use the controller to start a MATLAB server on a remote machine.

To do this, DCOM must be configured properly, and MATLAB must be installed on each machine that is used as a client or server. (Even though the client machine may not be running MATLAB in such a configuration, the client machine must have a MATLAB installation because certain MATLAB components are required to establish the remote connection.) Consult the DCOM documentation for how to configure DCOM for your environment.

Dynamic Data Exchange (DDE)

Note This section documents the MATLAB interface to the Dynamic Data Exchange (DDE) technology. As of MATLAB version 5.1, all development work for the DDE Server and Client has been stopped and no further development will be done. The MathWorks strongly recommends that you migrate to the MATLAB interface to COM technology that is documented at the beginning of the section “COM and DDE Support (Windows Only)” on page 8-1.

MATLAB provides functions that enable MATLAB to access other Windows applications and for other Windows applications to access MATLAB in a wide range of contexts. These functions use dynamic data exchange (DDE), software that allows Microsoft Windows applications to communicate with each other by exchanging data.

This section describes using DDE in MATLAB:

- “DDE Concepts and Terminology” on page 8-81
- “Accessing MATLAB as a Server” on page 8-83
- “The DDE Name Hierarchy” on page 8-84
- “Example — Using Visual Basic and the MATLAB DDE Server” on page 8-88
- “Using MATLAB as a Client” on page 8-90
- “Example — Importing Data From an Excel Application” on page 8-91
- “DDE Advisory Links” on page 8-92

DDE Concepts and Terminology

Applications communicate with each other by establishing a DDE *conversation*. The application that initiates the conversation is called the *client*. The application that responds to the client application is called the *server*.

When a client application initiates a DDE conversation, it must identify two DDE parameters that are defined by the server:

- The name of the application it intends to have the conversation with, called the *service name*
- The subject of the conversation, called the *topic*

When a server application receives a request for a conversation involving a supported topic, it acknowledges the request, establishing a DDE conversation. The combination of a service and a topic identifies a conversation uniquely. The service or topic cannot be changed for the duration of the conversation, although the service can maintain more than one conversation.

During a DDE conversation, the client and server applications exchange data concerning items. An *item* is a reference to data that is meaningful to both applications in a conversation. Either application can change the item during a conversation. These concepts are discussed in more detail below.

The Service Name

Every application that can be a DDE server has a unique *service name*. The service name is usually the application's executable filename without any extension. Service names are not case sensitive. Here are some commonly used service names:

- The service name for MATLAB is *Matlab*.
- The service name for Microsoft Word for Windows is *WinWord*.
- The service name for Microsoft Excel is *Excel*.

For the service names of other Windows applications, refer to the application documentation.

The Topic

The *topic* defines the subject of a DDE conversation and is usually meaningful to both the client and server applications. Topic names are not case sensitive. MATLAB topics are *System* and *Engine* and are discussed in "Accessing MATLAB as a Server" on page 8-83. Most applications support the *System* topic and at least one other topic. Consult your application documentation for information about supported topics.

The Item

Each topic supports one or more items. An *item* identifies the data being passed during the DDE conversation. Case sensitivity of items depends on the application. MATLAB *Engine* items are case sensitive if they refer to matrices because matrix names are case sensitive.

Clipboard Formats

DDE uses the Windows clipboard formats for formatting data sent between applications. As a client, MATLAB supports only Text format. As a server, MATLAB supports Text, Metafilepict, and XLTable formats, described below:

- **Text** – Data in Text format is a buffer of characters terminated by the null character. Lines of text in the buffer are delimited by a carriage return line-feed combination. If the buffer contains columns of data, those columns are delimited by the tab character. MATLAB supports Text format for obtaining the results of a remote EvalString command and requests for matrix data. Also, matrix data can be sent to MATLAB in Text format.
- **Metafilepict** – Metafilepict format is a description of graphical data containing the drawing commands for graphics. As a result, data stored in this format is scalable and device independent. MATLAB supports Metafilepict format for obtaining the result of a remote command that causes some graphic action to occur.
- **XLTable** – XLTable format is the clipboard format used by Microsoft Excel and is supported for ease and efficiency in exchanging data with Excel. XLTable format is a binary buffer with a header that describes the data held in the buffer. For a full description of XLTable format, consult the Microsoft Excel SDK documentation.

Accessing MATLAB as a Server

Note The MATLAB DDE server is disabled by default. To enable the DDE server start MATLAB with the /Automation option.

A client application can access MATLAB as a DDE server in the following ways, depending on the client application:

- If you are using an application that provides functions or macros to conduct DDE conversations, you can use these functions or macros. For example, Microsoft Excel, Word for Windows, and Visual Basic provide DDE functions or macros. For more information about using these functions or macros, see the appropriate Microsoft documentation.

- If you are creating your own application, you can use the MATLAB Engine Library or DDE directly. For more information about using the Engine Library, see “Using the MATLAB Engine” on page 6-2. For more information about using DDE routines, see the *Microsoft Windows Programmer’s Guide*.

The figure below illustrates how MATLAB communicates as a server. DDE functions in the client application communicate with the MATLAB DDE server module. The client’s DDE functions can be provided by either the application or the MATLAB Engine Library.



The DDE Name Hierarchy

When you access MATLAB as a server, you must specify its service name, topic, and item. The figure below illustrates the MATLAB DDE name hierarchy. Topics and items are described in more detail below.

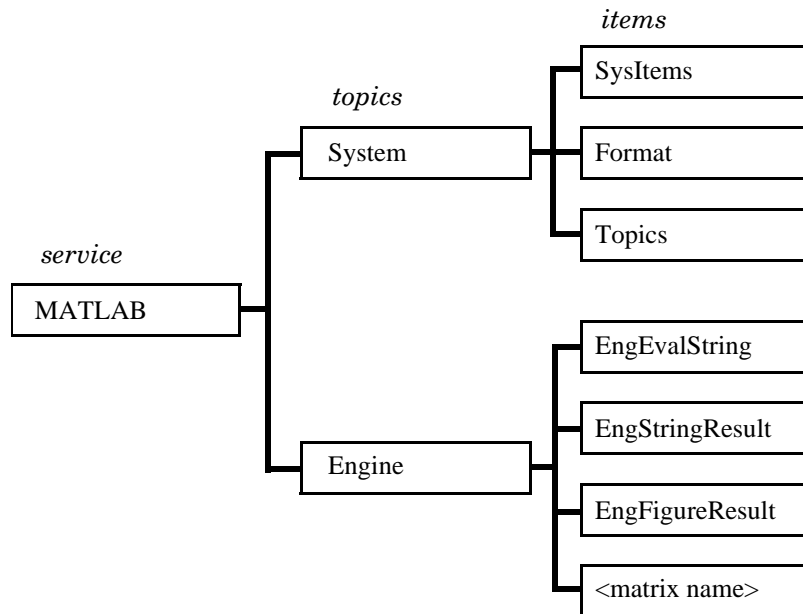

The two MATLAB topics are *System* and *Engine*.

MATLAB System Topic

The System topic allows users to browse the list of topics provided by the server, the list of System topic items provided by the server, and the formats supported by the server.

The MATLAB System topic supports these items:

- **SysItems**
Provides a tab-delimited list of items supported under the System topic (this list).
- **Format**
Provides a tab-delimited list of string names of all the formats supported by the server. MATLAB supports Text, Metafilepict, and XLTable. These formats are described in “Clipboard Formats” on page 8-83.

- **Topics**

Provides a tab-delimited list of the names of the topics supported by MATLAB.

MATLAB Engine Topic

The Engine topic allows users to use MATLAB as a server by passing it a command to execute, requesting data, or sending data.

The MATLAB Engine topic supports these items:

- **EngEvalString**

Specifies an item name, if required, when you send a command to MATLAB for evaluation.

- **EngStringResult**

Provides the string result of a DDE execute command when you request data from MATLAB.

- **EngFigureResult**

Provides the graphical result of a DDE execute command when you request data from MATLAB.

- **<matrix name>**

When requesting data from MATLAB, this is the name of the matrix for which data is being requested. When sending data to MATLAB, this is the name of the matrix to be created or updated.

The MATLAB Engine topic supports three operations that may be used by applications with a DDE client interface. These operations include sending commands to MATLAB for evaluation, requesting data from MATLAB, and sending data to MATLAB.

Sending Commands to MATLAB for Evaluation

Clients send commands to MATLAB using the DDE execute operation. The Engine topic supports DDE execute in two forms because some clients require that you specify the item name and the command to execute, while others require only the command. Where an item name is required, use EngEvalString. In both forms, the format of the command must be Text. Most

clients default to Text for DDE execute. If the format cannot be specified, it is probably Text. The table summarizes the DDE execute parameters.

Item	Format	Command
EngEvalString	Text	String
null	Text	String

Requesting Data from MATLAB

Clients request data from MATLAB using the DDE request operation. The Engine topic supports DDE requests for three functions:

Text that is the result of the previous DDE execute command. You request the string result of a DDE execute command using the EngStringResult item with Text format.

Graphical results of the previous DDE execute command. You request the graphical result of a DDE execute command using the EngFigureResult item. The EngFigureResult item can be used with Text or Metafile pict formats:

- Specifying the Text format results in a string having a value of “yes” or “no.” If the result is “yes,” the metafile for the current figure is placed on the clipboard. This functionality is provided for DDE clients that can retrieve only text from DDE requests, such as Word for Windows. If the result is “no,” no metafile is placed on the clipboard.
- Specifying the Metafile pict format when there is a graphical result causes a metafile to be returned directly from the DDE request.

The data for a specified matrix. You request the data for a matrix by specifying the name of the matrix as the item. You can specify either the Text or XLTable format.

The table summarizes the DDE request parameters.

Item	Format	Result
EngStringResult	Text	String
EngFigureResult	Text	Yes/No
EngFigureResult	Metafilepict	Metafile of the current figure
<matrix name>	Text	Character buffer, tab-delimited columns, CR/LF-delimited rows
<matrix name>	XLTable	Binary data in a format compatible with Microsoft Excel

Sending Data to MATLAB

Clients send data to MATLAB using the DDE poke operation. The Engine topic supports DDE poke for updating or creating new matrices in the MATLAB workspace. The item specified is the name of the matrix to be updated or created. If a matrix with the specified name already exists in the workspace it will be updated; otherwise it will be created. The matrix data can be in Text or XLTable format.

The table summarizes the DDE poke parameters.

Item	Format	Poke Data
<matrix name>	Text	Character buffer, tab-delimited columns, CR/LF-delimited rows
<matrix name>	XLTable	Binary data in a format compatible with Microsoft Excel

Example – Using Visual Basic and the MATLAB DDE Server

This example shows a Visual Basic form that contains two text edit controls, **TextInput** and **TextOutput**. This code is the `TextInput_KeyPress` method.

```
Sub TextInput_KeyPress(KeyAscii As Integer)
rem If the user presses the return key
rem in the TextInput control.
If KeyAscii = vbKeyReturn then

rem Initiate the conversation between the TextInput
rem control and MATLAB under the Engine topic.
rem Set the item to EngEvalString.
    TextInput.LinkMode = vbLinkNone
    TextInput.LinkTopic = "MATLAB|Engine"
    TextInput.LinkItem = "EngEvalString"
    TextInput.LinkMode = vbLinkManual

rem Get the current string in the TextInput control.
rem This text is the command string to send to MATLAB.
    szCommand = TextInput.Text

rem Perform DDE Execute with the command string.
    TextInput.LinkExecute szCommand
    TextInput.LinkMode = vbLinkNone

rem Initiate the conversation between the TextOutput
rem control and MATLAB under the Engine topic.
rem Set the item to EngStringResult.
    TextOutput.LinkMode = vbLinkNone
    TextOutput.LinkTopic = "MATLAB|Engine"
    TextOutput.LinkItem = "EngStringResult"
    TextOutput.LinkMode = vbLinkManual

rem Request the string result of the previous EngEvalString
rem command. The string ends up in the text field of the
rem control TextOutput.text.
    TextOutput.LinkRequest
    TextOutput.LinkMode = vbLinkNone

End If
End Sub
```

Using MATLAB as a Client

For MATLAB to act as a client application, you can use the MATLAB DDE client functions to establish and maintain conversations.

This figure illustrates how MATLAB communicates as a client to a server application.



The MATLAB DDE client module includes a set of functions. This table describes the functions that enable you to use MATLAB as a client.

Function	Description
ddeadv	Sets up advisory link between MATLAB and DDE server application.
ddeexec	Sends execution string to DDE server application.
ddeinit	Initiates DDE conversation between MATLAB and another application.
ddepoke	Sends data from MATLAB to DDE server application.
ddereq	Requests data from DDE server application.
ddeterm	Terminates DDE conversation between MATLAB and server application.
ddeunadv	Releases advisory link between MATLAB and DDE server application.

If the server application is Microsoft Excel, you can specify the *System* topic or a topic that is a filename. If you specify the latter, the filename ends in .XLS or

.XLC and includes the full path if necessary. A Microsoft Excel item is a cell reference, which can be an individual cell or a range of cells.

Microsoft Word for Windows topics are *System* and document names that are stored in files whose names end in .DOC or .DOT. A Word for Windows item is any bookmark in the document specified by the topic.

The following example is an M-file that establishes a DDE conversation with Microsoft Excel, and then passes a 20-by-20 matrix of data to Excel:

```
% Initialize conversation with Excel.
chan = ddeinit('excel', 'Sheet1');

% Create a surface of peaks plot.
h = surf(peaks(20));
% Get the z data of the surface
z = get(h, 'zdata');

% Set range of cells in Excel for poking.
range = 'r1c1:r20c20';

% Poke the z data to the Excel spread sheet.
rc = ddepoke(chan, range, z);
```

Example – Importing Data From an Excel Application

Assume that you have an Excel spreadsheet `stocks.xls`. This spreadsheet contains the prices of three stocks in row 3 (columns 1 through 3) and the number of shares of these stocks in rows 6 through 8 (column 2). Initiate conversation with Excel with the command

```
channel = ddeinit('excel','stocks.xls')
```

DDE functions require the `rxcy` reference style for Excel worksheets. In Excel terminology the prices are in `r3c1:r3c3` and the shares in `r6c2:r8c2`.

Request the prices from Excel:

```
prices = ddereq(channel, 'r3c1:r3c3')

prices =
    42.50    15.00    78.88
```

Next, request the number of shares of each stock:

```
shares = ddereq(channel, 'r6c2:r8c2')

shares =
    100.00
    500.00
    300.00
```

DDE Advisory Links

You can use DDE to notify a client application when data at a server has changed. For example, if you use MATLAB to analyze data entered in an Excel spreadsheet, you can establish a link that causes Excel to notify MATLAB when this data changes. You can also establish a link that automatically updates a matrix with the new or modified spreadsheet data.

MATLAB supports two kinds of advisory links, distinguished by the way in which the server application advises MATLAB when the data that is the subject of the item changes at the server:

- A *hot link* causes the server to supply the data to MATLAB when the data defined by the item changes.
- A *warm link* causes the server to notify MATLAB when the data changes but supplies the data only when MATLAB requests it.

You set up and release advisory links with the `ddeadv` and `ddeunadv` functions. MATLAB only supports links when MATLAB is a client.

This example establishes a DDE conversation between MATLAB, acting as a client, and Microsoft Excel. The example extends the example in the previous section by creating a hot link with Excel. The link updates matrix `z` and evaluates a callback when the range of cells changes. A push-button, user interface control terminates the advisory link and the DDE conversation when pressed. (For more information about creating a graphical user interface, see the online MATLAB manual, *Creating Graphical User Interfaces*.)

```
% Initialize conversation with Excel.
chan = ddeinit('excel', 'Sheet1');

% Set range of cells in Excel for poking.
range = 'r1c1:r20c20';
```

```
% Create a surface of peaks plot.
h = surf(peaks(20));

% Get the z data of the surface.
z = get(h, 'zdata');

% Poke the z data to the Excel spread sheet.
rc = ddepoke(chan, range, z);

% Set up a hot link ADVISE loop with Excel
% and the MATLAB matrix 'z'.
% The callback sets the zdata and cdata for
% the surface h to be the new data sent from Excel.
rc = ddeadv(chan, range,...
    'set(h, 'zdata',z);set(h, 'cdata',z);','z');

% Create a push button that will end the ADVISE link,
% terminate the DDE conversation,
% and close the figure window.
c = uicontrol('String','&Close','Position',[5 5 80 30],...
    'Callback',...
    'rc = ddeunadv(chan,range);ddeunadv(chan);close;');
```

Web Services in MATLAB

What Are Web Services in MATLAB? (p. 9-2)	Introduction to Web services in MATLAB
Using Web Services in MATLAB (p. 9-6)	Learn how to use Web services in MATLAB
Building MATLAB Applications with Web Services (p. 9-10)	Learn more about building MATLAB applications with Web services

What Are Web Services in MATLAB?

The term Web service encompasses a set of XML-based technologies for making remote procedure calls over a network. The network can be a local intranet within an organization or a remote server on the other side of the globe. In short, Web services are designed to let applications running on disparate operating systems and development platforms communicate with each other.

MATLAB acts as a web service client by sending requests to a server and handling the responses. MATLAB implements the following web service technologies:

- Simple Object Access Protocol (SOAP)
- Web Services Description Language (WSDL)

SOAP defines a standard for making XML-based exchanges between clients and servers. The client/server interaction, which usually takes place over HTTP, is initiated by the client. When the server receives the request, which includes the operation to be performed and any necessary parameters, it sends back a response.

The following example shows a simple HTTP-based SOAP request for retrieving the local temperature by zip code:

```
<?xml version='1.0' encoding='UTF-8'?>
  <SOAP-ENV:Envelope
xmlns:SOAP-ENV="http://schemas.xmlsoap.org/soap/envelope/"
  xmlns:xsi="http://www.w3.org/1999/XMLSchema-instance"
  xmlns:xsd="http://www.w3.org/1999/XMLSchema">
    <SOAP-ENV:Body>
      <tns:getTemp
        xmlns:tns="urn:xmethods-Temperature"
        SOAP-ENV:encodingStyle="http://schemas.xmlsoap.org/soap/encoding/">
        <zipcode>55406</zipcode>
      </tns:getTemp>
    </SOAP-ENV:Body>
  </SOAP-ENV:Envelope>
```

The SOAP protocol defines an envelope, and inside the envelope, defines a message body. Also, inside the message body, the SOAP method is specified, `getTemp`, as well as the `zipcode` parameter.

In the response sent by the server, notice that the SOAP message structure is similar:

```
<?xml version='1.0' encoding='UTF-8'?>
  <SOAP-ENV:Envelope
xmlns:SOAP-ENV="http://schemas.xmlsoap.org/soap/envelope/"
  xmlns:xsi="http://www.w3.org/2001/XMLSchema-instance"
  xmlns:xsd="http://www.w3.org/2001/XMLSchema">
    <SOAP-ENV:Body>
      <ns1:getTempResponse xmlns:ns1="urn:xmethods-Temperature"

SOAP-ENV:encodingStyle="http://schemas.xmlsoap.org/soap/encoding
/">
        <return xsi:type="xsd:float">19.0</return>
      </ns1:getTempResponse>
    </SOAP-ENV:Body>
  </SOAP-ENV:Envelope>
```

In the code, SOAP defines the envelope and message body as well as the response (return).

Most SOAP implementations use WSDL, an XML-based language, to describe and locate available services. The following example shows the message and service definitions of the WSDL file for the temperature service from the previous examples:

```
<?xml version="1.0"?>
<definitions name="TemperatureService"
targetNamespace="http://www.xmethods.net/sd/TemperatureService.w
sd1"
xmlns:tns="http://www.xmethods.net/sd/TemperatureService.wsdl"
xmlns:xsd="http://www.w3.org/2001/XMLSchema"
xmlns:soap="http://schemas.xmlsoap.org/wsdl/soap/"
xmlns="http://schemas.xmlsoap.org/wsdl/">
  <message name="getTempRequest">
    <part name="zipcode" type="xsd:string"/>
  </message>
  <message name="getTempResponse">
    <part name="return" type="xsd:float"/>
  </message>
<service name="TemperatureService">
```

```
        <documentation>Returns current temperature in a given U.S.  
            zipcode</documentation>  
        <port name="TemperaturePort"  
            binding="tns:TemperatureBinding">  
            <soap:address  
location="http://services.xmethods.net:80/soap/servlet/rpcrouter  
"/>  
            </port>  
        </service>  
    </definitions>
```

In the code, the request and response message actions (getTempRequest and getTempResponse) and the service name (TemperatureService) are defined.

Understanding Data Type Conversions

Using SOAP data types, MATLAB automatically converts XML data types to native MATLAB data types and vice versa. The following table contains the XML data type with the corresponding MATLAB data type:

XML Data Type	MATLAB Data Type
string	char array
boolean	logical scalar
decimal	double scalar
float	double scalar
double	double scalar
duration	double scalar
time	double scalar
date	double scalar
gYearMonth	char array
gYear	char array
gMonthDay	char array

XML Data Type	MATLAB Data Type
hexbinary	double array
base64Binary	double array
anyURI	char array
QName	char array

Finding More Information About Web Services

To learn more about SOAP, see the following resources:

- World Wide Web Consortium (W3C) specification
- Apache Axis
- W3 Schools SOAP Tutorial

To learn more about WSDL, see the following resources:

- W3C specification
- WSDL4J Project
- W3 Schools WSDL Tutorial

To find publicly available Web services and for more information about popular development platforms for Web services, see the following resources:

- XMethods.net
- IBM developerWorks
- Java Web Services
- Microsoft Developer Network

Using Web Services in MATLAB

In MATLAB, you use the `createClassFromWsd1` function to call Web service methods. The function creates a MATLAB class based on the methods of the Web service application program interface (API).

Here is an example of the `createClassFromWsd1` function using a URL:

```
createClassFromWsd1('http://example.com/service.wsdl')
```

In the example, a URL to a WSDL file is passed to the function. The following example uses a file path instead of a URL:

```
createClassFromWsd1('\myservicedirectory\service.wsdl')
```

In the example, a relative file path is passed to the function. Keep in mind that target file must contain WSDL.

Note To call remote Web services with MATLAB, you must have a working Internet connection.

The following procedure walks you through the necessary steps to build a simple Web service. To begin, the procedure shows you how to find the temperature the Web service used in previous examples:

- 1 In a Web browser, go to the XMethods Web site at <http://www.xmethods.net>.

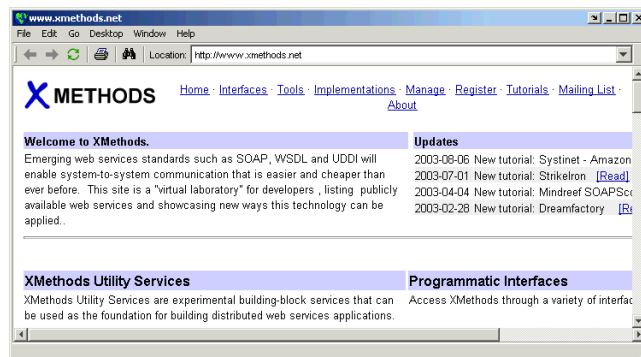

- 2 In **XMethods Demo Services**, click on the **Weather - Temperature** link.
- 3 On the **Weather - Temperature Web** page, you will find the **WSDL URL**, as well as links to analyze the WSDL. Click the **View RPC Profile** link.

In the **RPC Profile** page, you will see the available methods. In this case, the available method is **getTemp**.

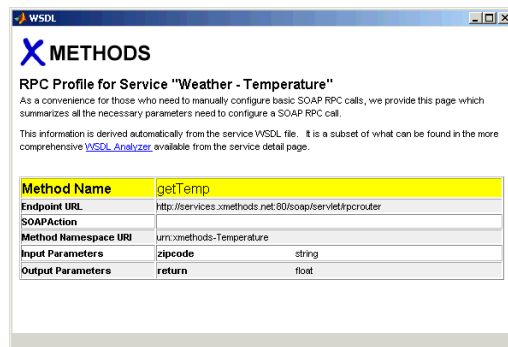

METHODS	
RPC Profile for Service "Weather - Temperature"	
As a convenience for those who need to manually configure basic SOAP RPC calls, we provide this page which summarizes all the necessary parameters need to configure a SOAP RPC call.	
This information is derived automatically from the service WSDL file. It is a subset of what can be found in the more comprehensive WSDL Analyzer available from the service detail page.	
Method Name	getTemp
Endpoint URL	http://services.xmethods.net:80/soap/Servlet#prouter
SOAP Action	
Method Namespace URI	urn:xmethods-Temperature
Input Parameters	zipcode string
Output Parameters	return float

In addition to the method name, you can see the input and output parameters and their data types. The output parameter returns a float data type. In “Understanding Data Type Conversions” on page 9-4, you see that MATLAB converts float to double scalar.

- 4 To use the `createClassFromWsd1` function, enter the following code at the MATLAB command line:

```
createClassFromWsd1('http://www.xmethods.net/sd/2001/Temperature
Service.wsdl');
```

You pass the WSDL URL to the `createClassFromWsd1` function. In response, MATLAB outputs

```
ans =
```

```
TemperatureService
```

This indicates that MATLAB has successfully parsed the WSDL and created the `TemperatureService` class. To view the methods associated with the `TemperatureService` class, enter the following code:

```
methods(TemperatureService)
```

MATLAB outputs

Methods for class TemperatureService:

```
display          TemperatureService
getTemp
```

- 5** In the current MATLAB directory, find the @TemperatureService folder. In the folder, you see the following files:
- `getTemp.m` — Contains the M-code for the `getTemp` method
 - `display.m` — Contains the M-code for a generic display method
 - `TemperatureService.m` — Contains the M-code for MATLAB object constructor

The `createClassFromWsd1` function automatically creates a file for each Web service method, a file for a generic display method, and a file for the Web service MATLAB object.

You can use the MATLAB help function to see the method signature, such as

```
help TemperatureService/getTemp
```

```
getTemp(obj,zipcode)
```

- 6** Call the `getTemp` method with the following code:

```
ts = TemperatureService;
getTemp(ts, '01760');
```

The `getTemp` method in MATLAB requires two arguments. It requires an instance of the `TemperatureService` class (`ts`) and the zip code (01760). In response, MATLAB outputs:

```
ans =
```

```
79
```

To review, the `createClassFromWsd1` function performs the following actions:

- Fetches and parses the WSDL to determine the Web service API
- Creates a folder, such as @TemperatureService, in the current MATLAB directory
- Creates the necessary M files in the directory, such as getTemp.m, display.m, and TemperatureService.m, based on the service API

For more information about object-oriented programming in MATLAB, see “Programming and Data Types” in the MATLAB documentation.

Building MATLAB Applications with Web Services

If you plan to build MATLAB applications with Web services, you will likely be using Web services to import data. Before implementing Web services in your applications, read the following sections:

- “Understanding Web Service Limitations” on page 9-10
- “Programming with Web Services” on page 9-10
- “Simple M Code Example” on page 9-11

Understanding Web Service Limitations

At the time of this writing, Web service technologies continue to evolve and change. The following list contains possible limitations that you should consider before building MATLAB applications with Web services:

- The majority of Web services are made available via HTTP. Like the Internet itself, quality of service cannot be guaranteed. Therefore, your application performance might suffer or might appear unreliable.
- Web services and the related technologies like WSDL and SOAP are relatively new. As with any new technology, established procedures and best practices are still being written.
- If you plan to call remote Web services, make sure that you validate their accuracy and reliability. Also, Web services that are free today might not remain free in the future.

Programming with Web Services

Because of the Internet is inherently unpredictable, make sure that you take proper precautions in programming with Web services. One way to ameliorate the risk is to use common program control and error-handling routines.

Common programming techniques that you might use include

- **Try - Catch statements** can catch errors that result from method calls as well as creating the MATLAB class from the WSDL. The following example shows a method call in a try - catch statement:

```
try
    t = getTemp(TemperatureService, '01760');
catch
```

```

        t = Nan;
        disp(lasterr);
    end

```

- **If statements** can check that expressions or statements are true or false. The following example uses an `if` statement to cache the WSDL locally:

```

wsdlUrl =
'http://www.xmethods.net/sd/2001/TemperatureService.wsdl';
wsdlFile = 'TemperatureService.wsdl';
if ~(exist(wsdlFile,'file') == 2)
    urlwrite(wsdlUrl,wsdlFile);
end

```

- **Error functions** can be used to throw specific errors. The following example shows an error function used in an `try - catch` statement:

```

try
    t = getTemp(TemperatureService, '01760');
catch
    error('Could not return temperature');
end

```

For more information about program control and error-handling statements, see “Programming and Data Types” in the MATLAB documentation.

Simple M Code Example

The following M-code example provides a simple demonstration of programming with Web services. The script takes an array of zip codes and uses the temperature Web service to return the local temperatures. It then runs the `max`, `min`, and `median` functions on the temperatures:

```

% Create array with zip codes for Arkansas
zips = [71854 71901 72201 71601 72143 72904 72701 71971];
% Create empty array to contain temperature output
temps = [];

wsdlUrl =
'http://www.xmethods.net/sd/2001/TemperatureService.wsdl';
if ~(exist(wsdlFile,'file') == 2)
    urlwrite(wsdlUrl,wsdlFile);

```

```
end

% Catch errors during class creation
try
    % Create class from WSDL
    createClassFromWsd1(wsd1File);
catch
    % Throw error
    error('Unable to create WSDL class');
end
ts = TemperatureService;
% Iterate through zips array
for z = zips
    try
        % Call the getTemp method
        t = getTemp(ts, z);
    catch
        % Throw error
        t = NaN;
        warning(lasterr);
    end
    % Concatenate temperature to temps array
    temps = horzcat(temps, t);
end

% Display temps array
disp('Real-Time Temperatures for Arkansas');
disp(temps);
% Display highest temperature
disp('Highest Temperature in Arkansas');
disp(max(temps));
% Display lowest temperature
disp('Lowest Temperature in Arkansas');
disp(min(temps));
% Display temps median
disp('Median Temperature in Arkansas');
disp(median(temps));
% Display current date/time
disp('Date and Time Created:');
disp(datestr(now));
```

Serial Port I/O

Introduction (p. 10-3)	Serial port capabilities, supported interfaces, and supported platforms.
Overview of the Serial Port (p. 10-5)	The serial port interface standard, signals and pin assignments, the serial data format, and finding serial port information for your platform.
Getting Started with Serial I/O (p. 10-19)	Examples to help you get started with the serial port interface.
Creating a Serial Port Object (p. 10-25)	Create a MATLAB object that represents the serial I/O device.
Connecting to the Device (p. 10-28)	Establish a connection between MATLAB and the serial I/O device.
Configuring Communication Settings (p. 10-29)	Set values for the baud rate and the serial data format.
Writing and Reading Data (p. 10-30)	Write data to the device and read data from the device.
Events and Callbacks (p. 10-50)	Enhance your serial I/O application by using events and callbacks.
Using Control Pins (p. 10-58)	Signal the presence of connected devices and control the flow of data.
Debugging: Recording Information to Disk (p. 10-64)	Save transferred data and event information to disk.
Saving and Loading (p. 10-70)	Save and load serial port objects.

Disconnecting and Cleaning Up (p. 10-71) Disconnect the serial port object from the device, and remove the object from memory and from the workspace.

Property Reference (p. 10-72) Properties grouped by category.

Introduction

What Is the MATLAB Serial Port Interface?

The MATLAB serial port interface provides direct access to peripheral devices such as modems, printers, and scientific instruments that you connect to your computer's serial port. This interface is established through a serial port object. The serial port object supports functions and properties that allow you to

- Configure serial port communications
- Use serial port control pins
- Write and read data
- Use events and callbacks
- Record information to disk

If you want to communicate with PC-compatible data acquisition hardware such as multifunction I/O boards, you need the Data Acquisition Toolbox. If you want to communicate with GPIB- or VISA-compatible instruments, you need the Instrument Control Toolbox. Note that this toolbox also includes additional serial I/O utility functions that facilitate object creation and configuration, instrument communication, and so on.

For more information about these products, visit the MathWorks Web site at <http://www.mathworks.com/products>.

Supported Serial Port Interface Standards

Over the years, several serial port interface standards have been developed. These standards include RS-232, RS-422, and RS-485 – all of which are supported by the MATLAB serial port object. Of these, the most widely used interface standard for connecting computers to peripheral devices is RS-232.

In this guide, it is assumed you are using the RS-232 standard, which is discussed in “Overview of the Serial Port” on page 10-5. Refer to your computer and device documentation to see which interface standard you can use.

Supported Platforms

The MATLAB serial port interface is supported on Microsoft Windows, Linux, and Sun Solaris platforms.

Using the Examples with Your Device

Many of the examples in this section reflect specific peripheral devices connected to a PC serial port – in particular a Tektronix TDS 210 two-channel oscilloscope connected to the COM1 port. Therefore, many of the string commands are specific to this instrument.

If your peripheral device is connected to a different serial port, or if it accepts different commands, you should modify the examples accordingly.

Overview of the Serial Port

This section provides an overview of the serial port. Topics include

- What is Serial Communication?
- The Serial Port Interface Standard
- Connecting Two Devices with a Serial Cable
- Serial Port Signals and Pin Assignments
- Serial Data Format
- Finding Serial Port Information for Your Platform

For many serial port applications, you can communicate with your device without detailed knowledge of how the serial port works. If your application is straightforward, or if you are already familiar with the topics mentioned above, you might want to begin with “The Serial Port Session” on page 10-20 to see how to use your serial port device with MATLAB.

What Is Serial Communication?

Serial communication is the most common low-level protocol for communicating between two or more devices. Normally, one device is a computer, while the other device can be a modem, a printer, another computer, or a scientific instrument such as an oscilloscope or a function generator.

As the name suggests, the serial port sends and receives bytes of information in a serial fashion – one bit at a time. These bytes are transmitted using either a binary (numerical) format or a text format.

The Serial Port Interface Standard

The serial port interface for connecting two devices is specified by the TIA/EIA-232C standard published by the Telecommunications Industry Association.

The original serial port interface standard was given by RS-232, which stands for Recommended Standard number 232. The term “RS-232” is still in popular use, and is used in this guide when referring to a serial communication port that follows the TIA/EIA-232 standard. RS-232 defines these serial port characteristics:

- The maximum bit transfer rate and cable length

- The names, electrical characteristics, and functions of signals
- The mechanical connections and pin assignments

Primary communication is accomplished using three pins: the Transmit Data pin, the Receive Data pin, and the Ground pin. Other pins are available for data flow control, but are not required.

Other standards such as RS-485 define additional functionality such as higher bit transfer rates, longer cable lengths, and connections to as many as 256 devices.

Connecting Two Devices with a Serial Cable

The RS-232 standard defines the two devices connected with a serial cable as the Data Terminal Equipment (DTE) and Data Circuit-Terminating Equipment (DCE). This terminology reflects the RS-232 origin as a standard for communication between a computer terminal and a modem.

Throughout this guide, your computer is considered a DTE, while peripheral devices such as modems and printers are considered DCE's. Note that many scientific instruments function as DTE's.

Because RS-232 mainly involves connecting a DTE to a DCE, the pin assignments are defined such that straight-through cabling is used, where pin 1 is connected to pin 1, pin 2 is connected to pin 2, and so on. A DTE to DCE serial connection using the transmit data (TD) pin and the receive data (RD) pin is shown below. Refer to "Serial Port Signals and Pin Assignments" on page 10-7 for more information about serial port pins.

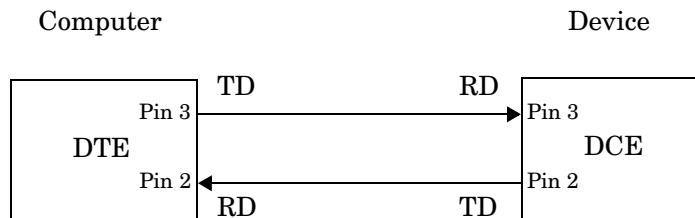

If you connect two DTE's or two DCE's using a straight serial cable, then the TD pin on each device are connected to each other, and the RD pin on each device are connected to each other. Therefore, to connect two like devices, you must use a *null modem* cable. As shown below, null modem cables cross the transmit and receive lines in the cable.

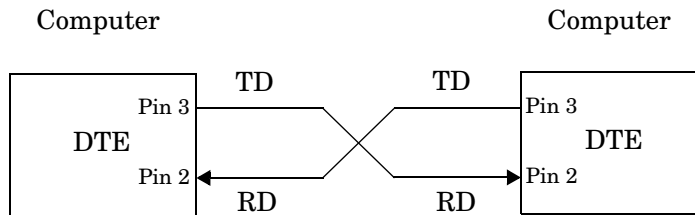

Note You can connect multiple RS-422 or RS-485 devices to a serial port. If you have an RS-232/RS-485 adaptor, then you can use the MATLAB serial port object with these devices.

Serial Port Signals and Pin Assignments

Serial ports consist of two signal types: data signals and control signals. To support these signal types, as well as the signal ground, the RS-232 standard defines a 25-pin connection. However, most PC's and UNIX platforms use a 9-pin connection. In fact, only three pins are required for serial port communications: one for receiving data, one for transmitting data, and one for the signal ground.

The pin assignment scheme for a 9-pin male connector on a DTE is given below.

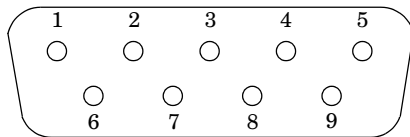

The pins and signals associated with the 9-pin connector are described below. Refer to the RS-232 standard for a description of the signals and pin assignments used for a 25-pin connector.

Table 10-1: Serial Port Pin and Signal Assignments

Pin	Label	Signal Name	Signal Type
1	CD	Carrier Detect	Control
2	RD	Received Data	Data
3	TD	Transmitted Data	Data
4	DTR	Data Terminal Ready	Control
5	GND	Signal Ground	Ground
6	DSR	Data Set Ready	Control
7	RTS	Request to Send	Control
8	CTS	Clear to Send	Control
9	RI	Ring Indicator	Control

The term “data set” is synonymous with “modem” or “device,” while the term “data terminal” is synonymous with “computer.”

Note The serial port pin and signal assignments are with respect to the DTE. For example, data is transmitted from the TD pin of the DTE to the RD pin of the DCE.

Signal States

Signals can be in either an *active* state or an *inactive* state. An active state corresponds to the binary value 1, while an inactive state corresponds to the binary value 0. An active signal state is often described as *logic 1*, *on*, *true*, or a *mark*. An inactive signal state is often described as *logic 0*, *off*, *false*, or a *space*.

For data signals, the “on” state occurs when the received signal voltage is more negative than -3 volts, while the “off” state occurs for voltages more positive than 3 volts. For control signals, the “on” state occurs when the received signal voltage is more positive than 3 volts, while the “off” state occurs for voltages more negative than -3 volts. The voltage between -3 volts and +3 volts is considered a transition region, and the signal state is undefined.

To bring the signal to the “on” state, the controlling device *unasserts* (or *lowers*) the value for data pins and *asserts* (or *raises*) the value for control pins. Conversely, to bring the signal to the “off” state, the controlling device asserts the value for data pins and unasserts the value for control pins.

The “on” and “off” states for a data signal and for a control signal are shown below.

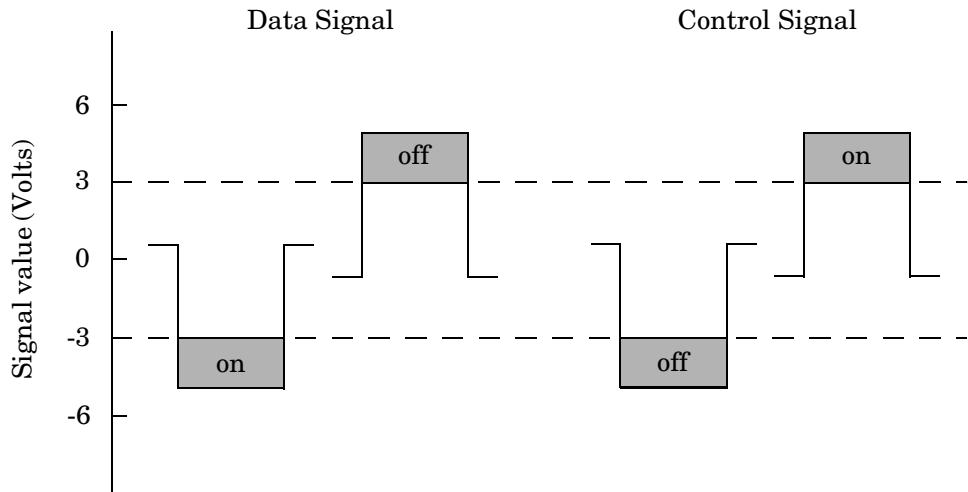

The Data Pins

Most serial port devices support *full-duplex* communication meaning that they can send and receive data at the same time. Therefore, separate pins are used for transmitting and receiving data. For these devices, the TD, RD, and GND pins are used. However, some types of serial port devices support only one-way or *half-duplex* communications. For these devices, only the TD and GND pins are used. In this guide, it is assumed that a full-duplex serial port is connected to your device.

The TD pin carries data transmitted by a DTE to a DCE. The RD pin carries data that is received by a DTE from a DCE.

The Control Pins

9-pin serial ports provide several control pins that:

- Signal the presence of connected devices
- Control the flow of data

The control pins include RTS and CTS, DTR and DSR, CD, and RI.

The RTS and CTS Pins. The RTS and CTS pins are used to signal whether the devices are ready to send or receive data. This type of data flow control – called hardware handshaking – is used to prevent data loss during transmission. When enabled for both the DTE and DCE, hardware handshaking using RTS and CTS follows these steps:

- 1 The DTE asserts the RTS pin to instruct the DCE that it is ready to receive data.
- 2 The DCE asserts the CTS pin indicating that it is clear to send data over the TD pin. If data can no longer be sent, the CTS pin is unasserted.
- 3 The data is transmitted to the DTE over the TD pin. If data can no longer be accepted, the RTS pin is unasserted by the DTE and the data transmission is stopped.

To enable hardware handshaking in MATLAB, refer to “Controlling the Flow of Data: Handshaking” on page 10-61.

The DTR and DSR Pins. Many devices use the DSR and DTR pins to signal if they are connected and powered. Signaling the presence of connected devices using DTR and DSR follows these steps:

- 1 The DTE asserts the DTR pin to request that the DCE connect to the communication line.
- 2 The DCE asserts the DSR pin to indicate it’s connected.
- 3 DCE unasserts the DSR pin when it’s disconnected from the communication line.

The DTR and DSR pins were originally designed to provide an alternative method of hardware handshaking. However, the RTS and CTS pins are usually used in this way, and not the DSR and DTR pins. However, you should refer to your device documentation to determine its specific pin behavior.

The CD and RI Pins. The CD and RI pins are typically used to indicate the presence of certain signals during modem-modem connections.

CD is used by a modem to signal that it has made a connection with another modem, or has detected a carrier tone. CD is asserted when the DCE is

receiving a signal of a suitable frequency. CD is unasserted if the DCE is not receiving a suitable signal.

RI is used to indicate the presence of an audible ringing signal. RI is asserted when the DCE is receiving a ringing signal. RI is unasserted when the DCE is not receiving a ringing signal (for example, it's between rings).

Serial Data Format

The serial data format includes one start bit, between five and eight data bits, and one stop bit. A parity bit and an additional stop bit might be included in the format as well. The diagram below illustrates the serial data format.

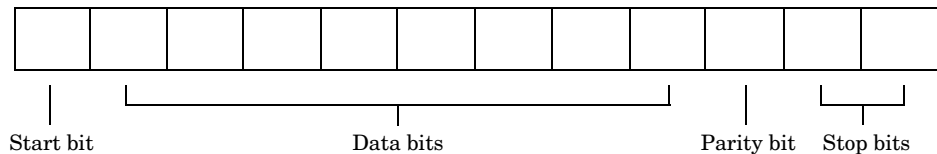

The format for serial port data is often expressed using the following notation
number of data bits - parity type - number of stop bits

For example, 8-N-1 is interpreted as eight data bits, no parity bit, and one stop bit, while 7-E-2 is interpreted as seven data bits, even parity, and two stop bits.

The data bits are often referred to as a *character* because these bits usually represent an ASCII character. The remaining bits are called *framing bits* because they frame the data bits.

Bytes Versus Values

The collection of bits that comprise the serial data format is called a *byte*. At first, this term might seem inaccurate because a byte is 8 bits and the serial data format can range between 7 bits and 12 bits. However, when serial data is stored on your computer, the framing bits are stripped away, and only the data bits are retained. Moreover, eight data bits are always used regardless of

the number of data bits specified for transmission, with the unused bits assigned a value of 0.

When reading or writing data, you might need to specify a *value*, which can consist of one or more bytes. For example, if you read one value from a device using the `int32` format, then that value consists of four bytes. For more information about reading and writing values, refer to “Writing and Reading Data” on page 10-30.

Synchronous and Asynchronous Communication

The RS-232 standard supports two types of communication protocols: synchronous and asynchronous.

Using the synchronous protocol, all transmitted bits are synchronized to a common clock signal. The two devices initially synchronize themselves to each other, and then continually send characters to stay synchronized. Even when actual data is not really being sent, a constant flow of bits allows each device to know where the other is at any given time. That is, each bit that is sent is either actual data or an idle character. Synchronous communications allows faster data transfer rates than asynchronous methods, because additional bits to mark the beginning and end of each data byte are not required.

Using the asynchronous protocol, each device uses its own internal clock resulting in bytes that are transferred at arbitrary times. So, instead of using time as a way to synchronize the bits, the data format is used.

In particular, the data transmission is synchronized using the start bit of the word, while one or more stop bits indicate the end of the word. The requirement to send these additional bits causes asynchronous communications to be slightly slower than synchronous. However, it has the advantage that the processor does not have to deal with the additional idle characters. Most serial ports operate asynchronously.

Note When used in this guide, the terms “synchronous” and “asynchronous” refer to whether read or write operations block access to the MATLAB command line. Refer to “Controlling Access to the MATLAB Command Line” on page 10-30 for more information.

How Are the Bits Transmitted?

By definition, serial data is transmitted one bit at a time. The order in which the bits are transmitted is given below:

- 1** The start bit is transmitted with a value of 0.
- 2** The data bits are transmitted. The first data bit corresponds to the least significant bit (LSB), while the last data bit corresponds to the most significant bit (MSB).
- 3** The parity bit (if defined) is transmitted.
- 4** One or two stop bits are transmitted, each with a value of 1.

The number of bits transferred per second is given by the *baud rate*. The transferred bits include the start bit, the data bits, the parity bit (if defined), and the stop bits.

Start and Stop Bits

As described in “Synchronous and Asynchronous Communication” on page 10-13, most serial ports operate asynchronously. This means that the transmitted byte must be identified by start and stop bits. The start bit indicates when the data byte is about to begin and the stop bit(s) indicates when the data byte has been transferred. The process of identifying bytes with the serial data format follows these steps:

- 1** When a serial port pin is idle (not transmitting data), then it is in an “on” state.
- 2** When data is about to be transmitted, the serial port pin switches to an “off” state due to the start bit.
- 3** The serial port pin switches back to an “on” state due to the stop bit(s). This indicates the end of the byte.

Data Bits

The data bits transferred through a serial port might represent device commands, sensor readings, error messages, and so on. The data can be transferred as either binary data or ASCII data.

Most serial ports use between five and eight data bits. Binary data is typically transmitted as eight bits. Text-based data is transmitted as either seven bits or eight bits. If the data is based on the ASCII character set, then a minimum of seven bits is required because there are 2^7 or 128 distinct characters. If an eighth bit is used, it must have a value of 0. If the data is based on the extended ASCII character set, then eight bits must be used because there are 2^8 or 256 distinct characters.

The Parity Bit

The parity bit provides simple error (parity) checking for the transmitted data. The types of parity checking are given below.

Table 10-2: Parity Types

Parity Type	Description
Even	The data bits plus the parity bit result in an even number of 1's.
Mark	The parity bit is always 1.
Odd	The data bits plus the parity bit result in an odd number of 1's.
Space	The parity bit is always 0.

Mark and space parity checking are seldom used because they offer minimal error detection. You might choose to not use parity checking at all.

The parity checking process follows these steps:

- 1 The transmitting device sets the parity bit to 0 or to 1 depending on the data bit values and the type of parity checking selected.
- 2 The receiving device checks if the parity bit is consistent with the transmitted data. If it is, then the data bits are accepted. If it is not, then an error is returned.

Note Parity checking can detect only 1-bit errors. Multiple-bit errors can appear as valid data.

For example, suppose the data bits 01110001 are transmitted to your computer. If even parity is selected, then the parity bit is set to 0 by the transmitting device to produce an even number of 1's. If odd parity is selected, then the parity bit is set to 1 by the transmitting device to produce an odd number of 1's.

Finding Serial Port Information for Your Platform

The ways to find serial port information for Windows and UNIX platforms are described below.

Note Your operating system provides default values for all serial port settings. However, these settings are overridden by your MATLAB code, and will have no effect on your serial port application.

Windows Platform

You can easily access serial port information through the Windows Control Panel. You can invoke the Control Panel with the **Start** button (**Start -> Settings -> Control Panel**).

For Windows NT, you access the serial ports by selecting the Ports icon within the Control Panel. The resulting **Ports** dialog box is shown below.

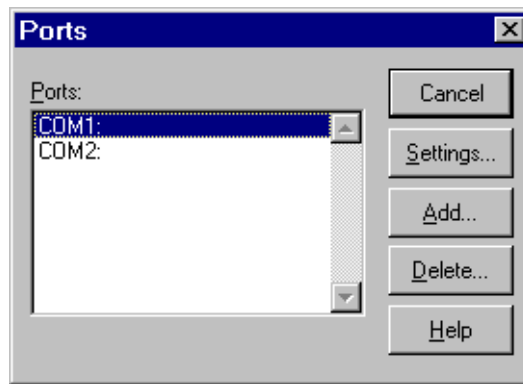

To obtain information on the possible settings for COM1, select this port under the **Ports** list box and then select **Settings**.

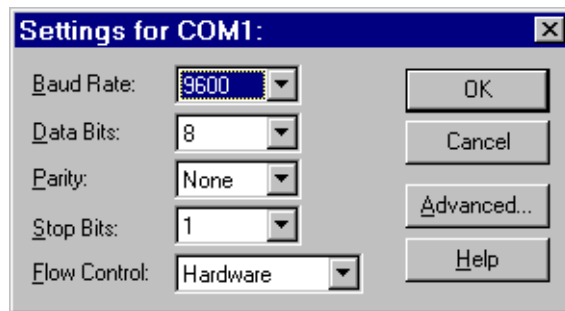

You can access serial port information for the Windows 2000 operating system with the **System Properties** dialog box, which is available through the Control Panel.

UNIX Platform

To find serial port information for UNIX platforms, you need to know the serial port names. These names might vary between different operating systems.

On Linux, serial port devices are typically named `ttyS0`, `ttyS1`, and so on. You can use the `setserial` command to display or configure serial port information. For example, to display which ports are available

```
setserial -bg /dev/ttyS*
```

```
/dev/ttyS0 at 0x03f8 (irq = 4) is a 16550A
/dev/ttyS1 at 0x02f8 (irq = 3) is a 16550A
```

To display detailed information about ttyS0

```
setserial -ag /dev/ttyS0
/dev/ttyS0, Line 0, UART: 16550A, Port: 0x03f8, IRQ: 4
  Baud_base: 115200, close_delay: 50, divisor: 0
  closing_wait: 3000, closing_wait2: infinte
  Flags: spd_normal skip_test session_lockout
```

Note If the `setserial -ag` command does not work, make sure that you have read and write permission for the port.

For all supported UNIX platforms, you can use the `stty` command to display or configure serial port information. For example, to display serial port properties for ttyS0

```
stty -a < /dev/ttyS0
```

To configure the baud rate to 4800 bits per second

```
stty speed 4800 < /dev/ttyS0 > /dev/ttyS0
```

Selected Bibliography

- 1 TIA/EIA-232-F, *Interface Between Data Terminal Equipment and Data Circuit-Terminating Equipment Employing Serial Binary Data Interchange*.
- 2 Jan Axelson, *Serial Port Complete*, Lakeview Research, Madison, WI, 1998.
- 3 *Instrument Communication Handbook*, IOTech, Inc., Cleveland, OH, 1991.
- 4 *TDS 200-Series Two Channel Digital Oscilloscope Programmer Manual*, Tektronix, Inc., Wilsonville, OR.
- 5 *Courier High Speed Modems User's Manual*, U.S. Robotics, Inc., Skokie, IL, 1994.

Getting Started with Serial I/O

To get you started with the MATLAB serial port interface, this section provides the following information:

- “Example: Getting Started” on page 10-19 illustrates some basic serial port commands.
- “The Serial Port Session” on page 10-20 describes the steps you use to perform any serial port task from beginning to end.
- “Configuring and Returning Properties” on page 10-21 describes how you display serial port property names and property values, and how you assign values to properties.

Example: Getting Started

If you have a device connected to the serial port COM1 and configured for a baud rate of 4800, you can execute the following complete example.

```
s = serial('COM1');
set(s, 'BaudRate', 4800);
fopen(s);
fprintf(s, '*IDN?')
out = fscanf(s);
fclose(s)
delete(s)
clear s
```

The *IDN? command queries the device for identification information, which is returned to out. If your device does not support this command, or if it is connected to a different serial port, you should modify the above example accordingly.

Note *IDN? is one of the commands supported by the Standard Commands for Programmable Instruments (SCPI) language, which is used by many modern devices. Refer to your device documentation to see if it supports the SCPI language.

The Serial Port Session

The serial port *session* comprises all the steps you are likely to take when communicating with a device connected to a serial port. These steps are:

- 1 Create a serial port object** – You create a serial port object for a specific serial port using the serial creation function.

You can also configure properties during object creation. In particular, you might want to configure properties associated with serial port communications such as the baud rate, the number of data bits, and so on.

- 2 Connect to the device** – You connect the serial port object to the device using the `fopen` function.

After the object is connected, you can alter device settings by configuring property values, read data, and write data.

- 3 Configure properties** – To establish the desired serial port object behavior, you assign values to properties using the `set` function or dot notation.

In practice, you can configure many of the properties at any time including during, or just after, object creation. Conversely, depending on your device settings and the requirements of your serial port application, you might be able to accept the default property values and skip this step.

- 4 Write and read data** – You can now write data to the device using the `fprintf` or `fwrite` function, and read data from the device using the `fgetl`, `fgets`, `fread`, `fscanf`, or `readasynch` function.

The serial port object behaves according to the previously configured or default property values.

- 5 Disconnect and clean up** – When you no longer need the serial port object, you should disconnect it from the device using the `fclose` function, remove it from memory using the `delete` function, and remove it from the MATLAB workspace using the `clear` command.

The serial port session is reinforced in many of the serial port documentation examples. Refer to “Example: Getting Started” on page 10-19 to see a basic example that uses the steps shown above.

Configuring and Returning Properties

You establish the desired serial port object behavior by configuring property values. You can display or configure property values using the set function, the get function, or dot notation.

Displaying Property Names and Property Values

Once the serial port object is created, you can use the set function to display all the configurable properties to the command line. Additionally, if a property has a finite set of string values, then set also displays these values.

```
s = serial('COM1');
set(s)
  ByteOrder: [ {littleEndian} | bigEndian ]
  BytesAvailableFcn
  BytesAvailableFcnCount
  BytesAvailableFcnMode: [ {terminator} | byte ]
  ErrorFcn
  InputBufferSize
  Name
  OutputBufferSize
  OutputEmptyFcn
  RecordDetail: [ {compact} | verbose ]
  RecordMode: [ {overwrite} | append | index ]
  RecordName
  Tag
  Timeout
  TimerFcn
  TimerPeriod
  UserData

SERIAL specific properties:
  BaudRate
  BreakInterruptFcn
  DataBits
  DataTerminalReady: [ {on} | off ]
  FlowControl: [ {none} | hardware | software ]
  Parity: [ {none} | odd | even | mark | space ]
  PinStatusFcn
  Port
  ReadAsyncMode: [ {continuous} | manual ]
```

```
RequestToSend: [ {on} | off ]  
StopBits  
Terminator
```

You can use the get function to display one or more properties and their current values to the command line. To display all properties and their current values

```
get(s)  
  ByteOrder = littleEndian  
  BytesAvailable = 0  
  BytesAvailableFcn =  
  BytesAvailableFcnCount = 48  
  BytesAvailableFcnMode = terminator  
  BytesToOutput = 0  
  ErrorFcn =  
  InputBufferSize = 512  
  Name = Serial-COM1  
  OutputBufferSize = 512  
  OutputEmptyFcn =  
  RecordDetail = compact  
  RecordMode = overwrite  
  RecordName = record.txt  
  RecordStatus = off  
  Status = closed  
  Tag =  
  Timeout = 10  
  TimerFcn =  
  TimerPeriod = 1  
  TransferStatus = idle  
  Type = serial  
  UserData = []  
  ValuesReceived = 0  
  ValuesSent = 0  
  
  SERIAL specific properties:  
  BaudRate = 9600  
  BreakInterruptFcn =  
  DataBits = 8  
  DataTerminalReady = on  
  FlowControl = none
```

```

Parity = none
PinStatus = [1x1 struct]
PinStatusFcn =
Port = COM1
ReadAsyncMode = continuous
RequestToSend = on
StopBits = 1
Terminator = LF

```

To display the current value for one property, you supply the property name to `get`.

```

get(s, 'OutputBufferSize')
ans =
    512

```

To display the current values for multiple properties, you must include the property names as elements of a cell array.

```

get(s, {'Parity', 'TransferStatus'})
ans =
    'none'    'idle'

```

You can also use the dot notation to display a single property value.

```

s.Parity
ans =
    none

```

Configuring Property Values

You can configure property values using the `set` function

```

set(s, 'BaudRate', 4800);

```

or the dot notation.

```

s.BaudRate = 4800;

```

To configure values for multiple properties, you can supply multiple property name/property value pairs to `set`.

```

set(s, 'DataBits', 7, 'Name', 'Test1-serial')

```

Note that you can configure only one property value at a time using the dot notation.

In practice, you can configure many of the properties at any time while the serial port object exists – including during object creation. However, some properties are not configurable while the object is connected to the device or when recording information to disk. Refer to “Property Reference” on page 10-72 for information about when a property is configurable.

Specifying Property Names

Serial port property names are presented using mixed case. While this makes property names easier to read, you can use any case you want when specifying property names. Additionally, you need use only enough letters to identify the property name uniquely, so you can abbreviate most property names. For example, you can configure the BaudRate property any of these ways.

```
set(s, 'BaudRate', 4800)
set(s, 'baudrate', 4800)
set(s, 'BAUD', 4800)
```

When you include property names in an M-file, you should use the full property name. This practice can prevent problems with future releases of MATLAB if a shortened name is no longer unique because of the addition of new properties.

Default Property Values

Whenever you do not explicitly define a value for a property, then the default value is used. All configurable properties have default values.

Note Your operating system provides default values for all serial port settings such as the baud rate. However, these settings are overridden by your MATLAB code, and will have no effect on your serial port application.

If a property has a finite set of string values, then the default value is enclosed by {}. For example, the default value for the Parity property is none.

```
set(s, 'Parity')
[ {none} | odd | even | mark | space ]
```

You can find the default value for any property in the property reference pages.

Creating a Serial Port Object

You create a serial port object with the `serial` function. `serial` requires the name of the serial port connected to your device as an input argument. Additionally, you can configure property values during object creation. For example, to create a serial port object associated with the serial port COM1

```
s = serial('COM1');
```

The serial port object `s` now exists in the MATLAB workspace. You can display the class of `s` with the `whos` command.

```
whos s
  Name      Size      Bytes  Class
  -----
  s         1x1         512   serial object
```

```
Grand total is 11 elements using 512 bytes
```

Once the serial port object is created, the properties listed below are automatically assigned values. These general purpose properties provide descriptive information about the serial port object based on the object type and the serial port.

Table 10-3: Descriptive General Purpose Properties

Property Name	Description
Name	Specify a descriptive name for the serial port object
Port	Indicate the platform-specific serial port name
Type	Indicate the object type

You can display the values of these properties for `s` with the `get` function.

```
get(s,{'Name','Port','Type'})
ans =
    'Serial-COM1'    'COM1'    'serial'
```

Configuring Properties During Object Creation

You can configure serial port properties during object creation. `serial` accepts property names and property values in the same format as the `set` function. For example, you can specify property name/property value pairs.

```
s = serial('COM1', 'BaudRate', 4800, 'Parity', 'even');
```

If you specify an invalid property name, the object is not created. However, if you specify an invalid value for some properties (for example, `BaudRate` is set to 50), the object might be created but you will not be informed of the invalid value until you connect the object to the device with the `fopen` function.

The Serial Port Object Display

The serial port object provides you with a convenient display that summarizes important configuration and state information. You can invoke the display summary these three ways:

- Type the serial port object variable name at the command line.
- Exclude the semicolon when creating a serial port object.
- Exclude the semicolon when configuring properties using the dot notation.

The display summary for the serial port object `s` is given below.

```
Serial Port Object : Serial-COM1
```

Communication Settings

```
Port:          COM1
BaudRate:      9600
Terminator:    'LF'
```

Communication State

```
Status:        closed
RecordStatus:  off
```

Read/Write State

```
TransferStatus:  idle
BytesAvailable:  0
ValuesReceived:  0
ValuesSent:      0
```

Creating an Array of Serial Port Objects

In MATLAB, you can create an array from existing variables by concatenating those variables together. The same is true for serial port objects. For example, suppose you create the serial port objects `s1` and `s2`

```
s1 = serial('COM1');
s2 = serial('COM2');
```

You can now create a serial port object array consisting of `s1` and `s2` using the usual MATLAB syntax. To create the row array `x`

```
x = [s1 s2]
```

Instrument Object Array

Index:	Type:	Status:	Name:
1	serial	closed	Serial-COM1
2	serial	closed	Serial-COM2

To create the column array `y`

```
y = [s1;s2];
```

Note that you cannot create a matrix of serial port objects. For example, you cannot create the matrix

```
z = [s1 s2;s1 s2];
??? Error using ==> serial/vertcat
Only a row or column vector of instrument objects can be created.
```

Depending on your application, you might want to pass an array of serial port objects to a function. For example, to configure the baud rate and parity for `s1` and `s2` using one call to `set`

```
set(x, 'BaudRate', 19200, 'Parity', 'even')
```

Refer to the serial port function reference to see which functions accept a serial port object array as an input.

Connecting to the Device

Before you can use the serial port object to write or read data, you must connect it to your device via the serial port specified in the `serial` function. You connect a serial port object to the device with the `fopen` function.

```
fopen(s)
```

Some properties are read-only while the serial port object is connected and must be configured before using `fopen`. Examples include the `InputBufferSize` and the `OutputBufferSize` properties. Refer to “Property Reference” on page 10-72 to determine when you can configure a property.

Note You can create any number of serial port objects. However, you can connect only one serial port object to a given serial port at a time.

You can examine the `Status` property to verify that the serial port object is connected to the device.

```
s.Status
ans =
open
```

As illustrated below, the connection between the serial port object and the device is complete, and you can write and read data.

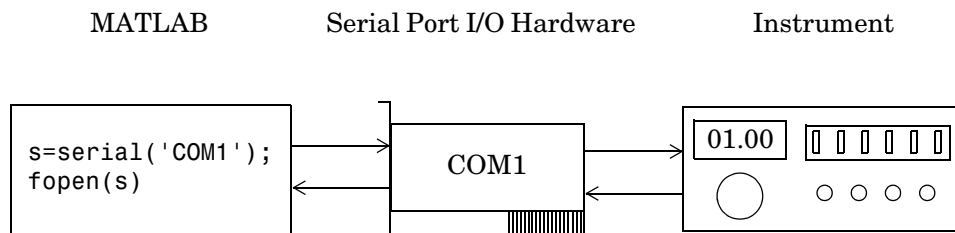

Configuring Communication Settings

Before you can write or read data, both the serial port object and the device must have identical communication settings. Configuring serial port communications involves specifying values for properties that control the baud rate and the serial data format. These properties are given below.

Table 10-4: Communication Properties

Property Name	Description
BaudRate	Specify the rate at which bits are transmitted
DataBits	Specify the number of data bits to transmit
Parity	Specify the type of parity checking
StopBits	Specify the number of bits used to indicate the end of a byte
Terminator	Specify the terminator character

Note If the serial port object and the device communication settings are not identical, then you cannot successfully read or write data.

Refer to your device documentation for an explanation of its supported communication settings.

Writing and Reading Data

For many serial port applications, there are three important questions that you should consider when writing or reading data:

- Will the read or write function block access to the MATLAB command line?
- Is the data to be transferred binary (numerical) or text?
- Under what conditions will the read or write operation complete?

For write operations, these questions are answered in “Writing Data” on page 10-32. For read operations, these questions are answered in “Reading Data” on page 10-37.

Example: Introduction to Writing and Reading Data

Suppose you want to return identification information for a Tektronix TDS 210 two-channel oscilloscope connected to the serial port COM1. This requires writing the *IDN? command to the instrument using the `fprintf` function, and then reading back the result of that command using the `fscanf` function.

```
s = serial('COM1');  
fopen(s)  
fprintf(s, '*IDN?')  
out = fscanf(s)
```

The resulting identification information is shown below.

```
out =  
TEKTRONIX,TDS 210,0,CF:91.1CT FV:v1.16 TDS2CM:CMV:v1.04
```

End the serial port session.

```
fclose(s)  
delete(s)  
clear s
```

Controlling Access to the MATLAB Command Line

You control access to the MATLAB command line by specifying whether a read or write operation is *synchronous* or *asynchronous*.

A synchronous operation blocks access to the command line until the read or write function completes execution. An asynchronous operation does not block

access to the command line, and you can issue additional commands while the read or write function executes in the background.

The terms “synchronous” and “asynchronous” are often used to describe how the serial port operates at the hardware level. The RS-232 standard supports an asynchronous communication protocol. Using this protocol, each device uses its own internal clock. The data transmission is synchronized using the start bit of the bytes, while one or more stop bits indicate the end of the byte. Refer to “Serial Data Format” on page 10-12 for more information on start bits and stop bits. The RS-232 standard also supports a synchronous mode where all transmitted bits are synchronized to a common clock signal.

At the hardware level, most serial ports operate asynchronously. However, using the default behavior for many of the read and write functions, you can mimic the operation of a synchronous serial port.

Note When used in this guide, the terms “synchronous” and “asynchronous” refer to whether read or write operations block access to the MATLAB command line. In other words, these terms describe how the software behaves, and not how the hardware behaves.

The two main advantages of writing or reading data asynchronously are:

- You can issue another command while the write or read function is executing.
- You can use all supported callback properties (see “Events and Callbacks” on page 10-50).

For example, because serial ports have separate read and write pins, you can simultaneously read and write data. This is illustrated below.

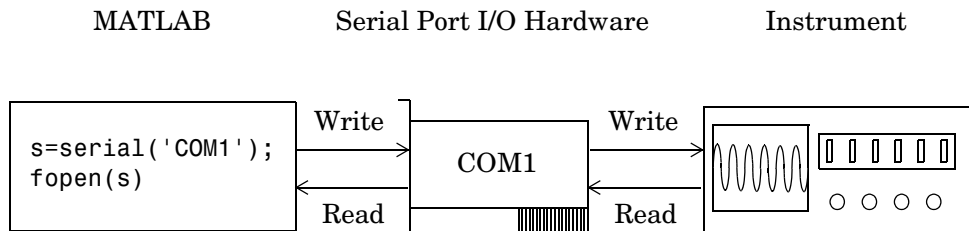

Writing Data

This section describes writing data to your serial port device in three parts:

- “The Output Buffer and Data Flow” on page 10-33 describes the flow of data from MATLAB to the device.
- “Writing Text Data” on page 10-35 describes how to write text data (string commands) to the device.
- “Writing Binary Data” on page 10-37 describes how to write binary (numerical) data to the device.

The functions associated with writing data are given below.

Table 10-5: Functions Associated with Writing Data

Function Name	Description
fprintf	Write text to the device
fwrite	Write binary data to the device
stopasync	Stop asynchronous read and write operations

The properties associated with writing data are given below.

Table 10-6: Properties Associated with Writing Data

Property Name	Description
BytesToOutput	Indicate the number of bytes currently in the output buffer
OutputBufferSize	Specify the size of the output buffer in bytes
Timeout	Specify the waiting time to complete a read or write operation
TransferStatus	Indicate if an asynchronous read or write operation is in progress
ValuesSent	Indicate the total number of values written to the device

The Output Buffer and Data Flow

The output buffer is computer memory allocated by the serial port object to store data that is to be written to the device. When writing data to your device, the data flow follows these two steps:

- 1 The data specified by the write function is sent to the output buffer.
- 2 The data in the output buffer is sent to the device.

The `OutputBufferSize` property specifies the maximum number of bytes that you can store in the output buffer. The `BytesToOutput` property indicates the number of bytes currently in the output buffer. The default values for these properties are given below.

```
s = serial('COM1');
get(s, {'OutputBufferSize', 'BytesToOutput'})
ans =
    [512]    [0]
```

If you attempt to write more data than can fit in the output buffer, an error is returned and no data is written.

For example, suppose you write the string command `*IDN?` to the TDS 210 oscilloscope using the `fprintf` function. As shown below, the string is first written to the output buffer as six values.

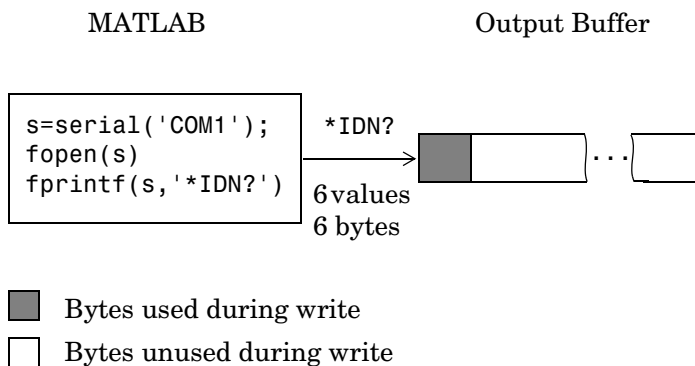

The `*IDN?` command consists of six values because the terminator is automatically written. Moreover, the default data format for the `fprintf` function specifies that one value corresponds to one byte. For more information about bytes and values, refer to “Bytes Versus Values” on page 10-12. `fprintf` and the terminator are discussed in “Writing Text Data” on page 10-35.

As shown below, after the string is written to the output buffer, it is then written to the device via the serial port.

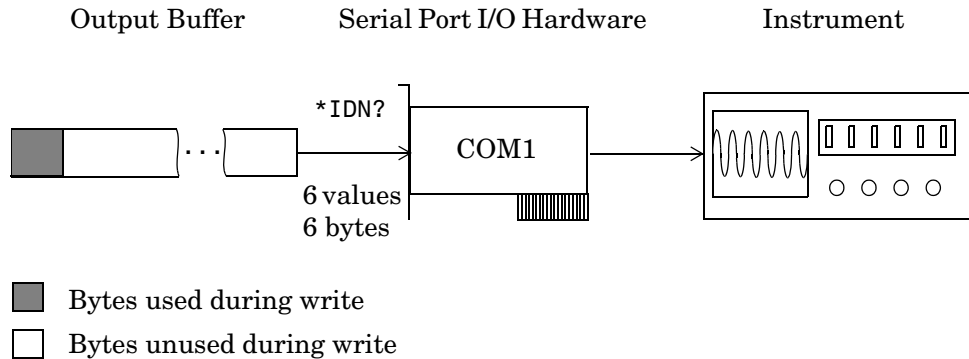

Writing Text Data

You use the `fprintf` function to write text data to the device. For many devices, writing text data means writing string commands that change device settings, prepare the device to return data or status information, and so on.

For example, the `Display:Contrast` command changes the display contrast of the oscilloscope.

```
s = serial('COM1');
fopen(s)
fprintf(s, 'Display:Contrast 45')
```

By default, `fprintf` writes data using the `%s\n` format because many serial port devices accept only text-based commands. However, you can specify many other formats as described in the `fprintf` reference pages.

You can verify the number of values sent to the device with the `ValuesSent` property.

```
s.ValuesSent
ans =
    20
```

Note that the `ValuesSent` property value includes the terminator because each occurrence of `\n` in the command sent to the device is replaced with the `Terminator` property value.

```
s.Terminator
ans =
LF
```

The default value of `Terminator` is the line feed character. The terminator required by your device will be described in its documentation.

Synchronous Versus Asynchronous Write Operations. By default, `fprintf` operates synchronously and will block the MATLAB command line until execution completes. To write text data asynchronously to the device, you must specify `async` as the last input argument to `fprintf`.

```
fprintf(s, 'Display:Contrast 45', 'async')
```

Asynchronous operations do not block access to the MATLAB command line. Additionally, while an asynchronous write operation is in progress, you can:

- Execute an asynchronous read operation because serial ports have separate pins for reading and writing
- Make use of all supported callback properties

You can determine which asynchronous operations are in progress with the `TransferStatus` property. If no asynchronous operations are in progress, then `TransferStatus` is `idle`.

```
s.TransferStatus
ans =
idle
```

Rules for Completing a Write Operation with `fprintf`. A synchronous or asynchronous write operation using `fprintf` completes when:

- The specified data is written.
- The time specified by the `Timeout` property passes.

Additionally, you can stop an asynchronous write operation with the `stopasync` function.

Writing Binary Data

You use the `fwrite` function to write binary data to the device. Writing binary data means writing numerical values. A typical application for writing binary data involves writing calibration data to an instrument such as an arbitrary waveform generator.

Note Some serial port devices accept only text-based commands. These commands might use the SCPI language or some other vendor-specific language. Therefore, you might need to use the `fprintf` function for all write operations.

By default, `fwrite` translates values using the `uchar` precision. However, you can specify many other precisions as described in the reference pages for this function.

By default, `fwrite` operates synchronously. To write binary data asynchronously to the device, you must specify `async` as the last input argument to `fwrite`. For more information about synchronous and asynchronous write operations, refer to the “Writing Text Data” on page 10-35. For a description of the rules used by `fwrite` to complete a write operation, refer to its reference pages.

Reading Data

This section describes reading data from your serial port device in three parts:

- “The Input Buffer and Data Flow” on page 10-39 describes the flow of data from the device to MATLAB.
- “Reading Text Data” on page 10-41 describes how to read from the device, and format the data as text.
- “Reading Binary Data” on page 10-43 describes how to read binary (numerical) data from the device.

The functions associated with reading data are given below.

Table 10-7: Functions Associated with Reading Data

Function Name	Description
<code>fgetc</code>	Read one line of text from the device and discard the terminator
<code>fgets</code>	Read one line of text from the device and include the terminator
<code>fread</code>	Read binary data from the device
<code>fscanf</code>	Read data from the device, and format as text
<code>readasync</code>	Read data asynchronously from the device
<code>stopasync</code>	Stop asynchronous read and write operations

The properties associated with reading data are given below.

Table 10-8: Properties Associated with Reading Data

Property Name	Description
<code>BytesAvailable</code>	Indicate the number of bytes available in the input buffer
<code>InputBufferSize</code>	Specify the size of the input buffer in bytes
<code>ReadAsyncMode</code>	Specify whether an asynchronous read operation is continuous or manual
<code>Timeout</code>	Specify the waiting time to complete a read or write operation
<code>TransferStatus</code>	Indicate if an asynchronous read or write operation is in progress
<code>ValuesReceived</code>	Indicate the total number of values read from the device

The Input Buffer and Data Flow

The input buffer is computer memory allocated by the serial port object to store data that is to be read from the device. When reading data from your device, the data flow follows these two steps:

- 1 The data read from the device is stored in the input buffer.
- 2 The data in the input buffer is returned to the MATLAB variable specified by the read function.

The `InputBufferSize` property specifies the maximum number of bytes that you can store in the input buffer. The `BytesAvailable` property indicates the number of bytes currently available to be read from the input buffer. The default values for these properties are given below.

```
s = serial('COM1');
get(s,{'InputBufferSize','BytesAvailable'})
ans =
    [512]    [0]
```

If you attempt to read more data than can fit in the input buffer, an error is returned and no data is read.

For example, suppose you use the `fscanf` function to read the text-based response of the `*IDN?` command previously written to the TDS 210 oscilloscope. As shown below, the text data is first read into to the input buffer via the serial port.

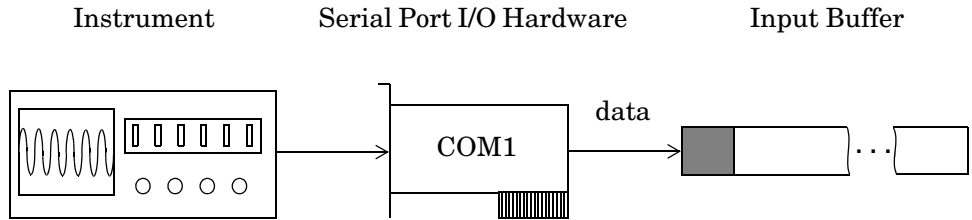

- Bytes used during read
- Bytes unused during read

Note that for a given read operation, you might not know the number of bytes returned by the device. Therefore, you might need to preset the `InputBufferSize` property to a sufficiently large value before connecting the serial port object.

As shown below, after the data is stored in the input buffer, it is then transferred to the output variable specified by `fscanf`.

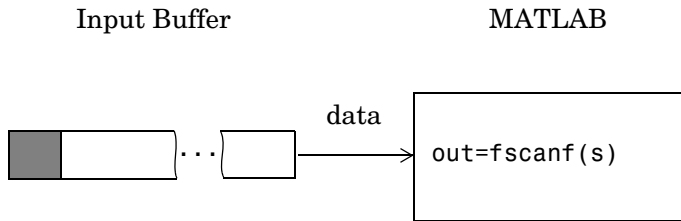

- Bytes used during read
- Bytes unused during read

Reading Text Data

You use the `fgetl`, `fgets`, and `fscanf` functions to read data from the device, and format the data as text.

For example, suppose you want to return identification information for the oscilloscope. This requires writing the `*IDN?` command to the instrument, and then reading back the result of that command.

```
s = serial('COM1');
fopen(s)
fprintf(s, '*IDN?')
out = fscanf(s)
out =
TEKTRONIX,TDS 210,0,CF:91.1CT FV:v1.16 TDS2CM:CMV:v1.04
```

By default, `fscanf` reads data using the `%c` format because the data returned by many serial port devices is text based. However, you can specify many other formats as described in the `fscanf` reference pages.

You can verify the number of values read from the device – including the terminator – with the `ValuesReceived` property.

```
s.ValuesReceived
ans =
    56
```

Synchronous Versus Asynchronous Read Operations. You specify whether read operations are synchronous or asynchronous with the `ReadAsyncMode` property. You can configure `ReadAsyncMode` to `continuous` or `manual`.

If `ReadAsyncMode` is `continuous` (the default value), the serial port object continuously queries the device to determine if data is available to be read. If data is available, it is asynchronously stored in the input buffer. To transfer the data from the input buffer to MATLAB, you use one of the synchronous (blocking) read functions such as `fgetl` or `fscanf`. If data is available in the input buffer, these functions will return quickly.

```
s.ReadAsyncMode = 'continuous';
fprintf(s, '*IDN?')
s.BytesAvailable
ans =
    56
out = fscanf(s);
```

If `ReadAsyncMode` is `manual`, the serial port object does not continuously query the device to determine if data is available to be read. To read data asynchronously, you use the `readasync` function. You then use one of the synchronous read functions to transfer data from the input buffer to MATLAB.

```
s.ReadAsyncMode = 'manual';
fprintf(s, '*IDN?')
s.BytesAvailable
ans =
    0
readasync(s)
s.BytesAvailable
ans =
   56
out = fscanf(s);
```

Asynchronous operations do not block access to the MATLAB command line. Additionally, while an asynchronous read operation is in progress, you can:

- Execute an asynchronous write operation because serial ports have separate pins for reading and writing
- Make use of all supported callback properties

You can determine which asynchronous operations are in progress with the `TransferStatus` property. If no asynchronous operations are in progress, then `TransferStatus` is `idle`.

```
s.TransferStatus
ans =
idle
```

Rules for Completing a Read Operation with `fscanf`. A read operation with `fscanf` blocks access to the MATLAB command line until:

- The terminator specified by the `Terminator` property is read.
- The time specified by the `Timeout` property passes.
- The specified number of values specified is read.
- The input buffer is filled.

Reading Binary Data

You use the `fread` function to read binary data from the device. Reading binary data means that you return numerical values to MATLAB.

For example, suppose you want to return the cursor and display settings for the oscilloscope. This requires writing the `CURSOR?` and `DISPLAY?` commands to the instrument, and then reading back the results of those commands.

```
s = serial('COM1');
fopen(s)
fprintf(s,'CURSOR?')
fprintf(s,'DISPLAY?')
```

Because the default value for the `ReadAsyncMode` property is `continuous`, data is asynchronously returned to the input buffer as soon as it is available from the device. You can verify the number of values read with the `BytesAvailable` property.

```
s.BytesAvailable
ans =
    69
```

You can return the data to MATLAB using any of the synchronous read functions. However, if you use `fgetl`, `fgets`, or `fscanf`, then you must issue the function twice because there are two terminators stored in the input buffer. If you use `fread`, then you can return all the data to MATLAB in one function call.

```
out = fread(s,69);
```

By default, `fread` returns numerical values in double precision arrays. However, you can specify many other precisions as described in the `fread` reference pages. You can convert the numerical data to text using the MATLAB `char` function.

```
val = char(out)
val =
HBARS;CH1;SECONDS;-1.0E-3;1.0E-3;VOLTS;-6.56E-1;6.24E-1
YT;DOTS;0;45
```

For more information about synchronous and asynchronous read operations, refer to “Reading Text Data” on page 10-41. For a description of the rules used by `fread` to complete a read operation, refer to its reference pages.

Example: Writing and Reading Text Data

This example illustrates how to communicate with a serial port instrument by writing and reading text data.

The instrument is a Tektronix TDS 210 two-channel oscilloscope connected to the COM1 port. Therefore, many of the commands given below are specific to this instrument. A sine wave is input into channel 2 of the oscilloscope, and your job is to measure the peak-to-peak voltage of the input signal.

- 1 Create a serial port object** – Create the serial port object `s` associated with serial port COM1.

```
s = serial('COM1');
```

- 2 Connect to the device** – Connect `s` to the oscilloscope. Because the default value for the `ReadAsyncMode` property is `continuous`, data is asynchronously returned to the input buffer as soon as it is available from the instrument.

```
fopen(s)
```

- 3 Write and read data** – Write the `*IDN?` command to the instrument using `fprintf`, and then read back the result of the command using `fscanf`.

```
fprintf(s, '*IDN?')
idn = fscanf(s)
idn =
TEKTRONIX,TDS 210,0,CF:91.1CT FV:v1.16 TDS2CM:CMV:v1.04
```

You need to determine the measurement source. Possible measurement sources include channel 1 and channel 2 of the oscilloscope.

```
fprintf(s, 'MEASUREMENT:IMMED:SOURCE?')
source = fscanf(s)
source =
CH1
```

The scope is configured to return a measurement from channel 1. Because the input signal is connected to channel 2, you must configure the instrument to return a measurement from this channel.

```
fprintf(s, 'MEASUREMENT:IMMED:SOURCE CH2')
fprintf(s, 'MEASUREMENT:IMMED:SOURCE?')
source = fscanf(s)
```



```
source =
CH2
```

You can now configure the scope to return the peak-to-peak voltage, and then request the value of this measurement.

```
fprintf(s, 'MEASUREMENT:MEAS1:TYPE PK2PK')
fprintf(s, 'MEASUREMENT:MEAS1:VALUE?')
```

Transfer data from the input buffer to MATLAB using `fscanf`.

```
ptop = fscanf(s, '%g')
ptop =
2.0199999809E0
```

- 4 Disconnect and clean up** – When you no longer need `s`, you should disconnect it from the instrument, and remove it from memory and from the MATLAB workspace.

```
fclose(s)
delete(s)
clear s
```

Example: Parsing Input Data Using `strread`

This example illustrates how to use the `strread` function to parse and format data that you read from a device. `strread` is particularly useful when you want to parse a string into one or more variables, where each variable has its own specified format.

The instrument is a Tektronix TDS 210 two-channel oscilloscope connected to the serial port COM1.

- 1 Create a serial port object** – Create the serial port object `s` associated with serial port COM1.

```
s = serial('COM1');
```

- 2 Connect to the device** – Connect `s` to the oscilloscope. Because the default value for the `ReadAsyncMode` property is `continuous`, data is asynchronously returned to the input buffer as soon as it is available from the instrument.

```
fopen(s)
```

- 3 Write and read data** – Write the RS232? command to the instrument using `fprintf`, and then read back the result of the command using `fscanf`. RS232? queries the RS-232 settings and returns the baud rate, the software flow control setting, the hardware flow control setting, the parity type, and the terminator.

```
fprintf(s, 'RS232?')
data = fscanf(s)
data =
9600;0;0;NONE;LF
```

Use the `strread` function to parse and format the data variable into five new variables.

```
[br,sfc,hfc,par,tm] = strread(data, '%d%d%d%s%s', 'delimiter', ';')

br =
    9600
sfc =
     0
hfc =
     0
par =
    'NONE'
tm =
    'LF'
```

- 4 Disconnect and clean up** – When you no longer need `s`, you should disconnect it from the instrument, and remove it from memory and from the MATLAB workspace.

```
fclose(s)
delete(s)
clear s
```

Example: Reading Binary Data

This example illustrates how you can download the TDS 210 oscilloscope screen display to MATLAB. The screen display data is transferred and saved to disk using the Windows bitmap format. This data provides a permanent record of your work, and is an easy way to document important signal and scope parameters.

Because the amount of data transferred is expected to be fairly large, it is asynchronously returned to the input buffer as soon as it is available from the instrument. This allows you to perform other tasks as the transfer progresses. Additionally, the scope is configured to its highest baud rate of 19,200.

- 1 Create a serial port object** – Create the serial port object `s` associated with serial port COM1.

```
s = serial('COM1');
```

- 2 Configure property values** – Configure the input buffer to accept a reasonably large number of bytes, and configure the baud rate to the highest value supported by the scope.

```
s.InputBufferSize = 50000;  
s.BaudRate = 19200;
```

- 3 Connect to the device** – Connect `s` to the oscilloscope. Because the default value for the `ReadAsyncMode` property is `continuous`, data is asynchronously returned to the input buffer as soon as it is available from the instrument.

```
fopen(s)
```

- 4 Write and read data** – Configure the scope to transfer the screen display as a bitmap.

```
fprintf(s, 'HARDCOPY:PORT RS232')  
fprintf(s, 'HARDCOPY:FORMAT BMP')  
fprintf(s, 'HARDCOPY START')
```

Wait until all the data is sent to the input buffer, and then transfer the data to the MATLAB workspace as unsigned 8-bit integers.

```
out = fread(s,s.BytesAvailable,'uint8');
```

- 5 Disconnect and clean up** – When you no longer need `s`, you should disconnect it from the instrument, and remove it from memory and from the MATLAB workspace.

```
fclose(s)  
delete(s)  
clear s
```

Viewing the Bitmap Data

To view the bitmap data, you should follow these steps:

- 1** Open a disk file.
- 2** Write the data to the disk file.
- 3** Close the disk file.
- 4** Read the data into MATLAB using the `imread` function.
- 5** Scale and display the data using the `imagesc` function.

Note that the file I/O versions of the `fopen`, `fwrite`, and `fclose` functions are used.

```
fid = fopen('test1.bmp','w');  
fwrite(fid,out,'uint8');  
fclose(fid)  
a = imread('test1.bmp','bmp');  
imagesc(a)
```

Because the scope returns the screen display data using only two colors, an appropriate colormap is selected.

```
mymap = [0 0 0; 1 1 1];  
colormap(mymap)
```

The resulting bitmap image is shown below.

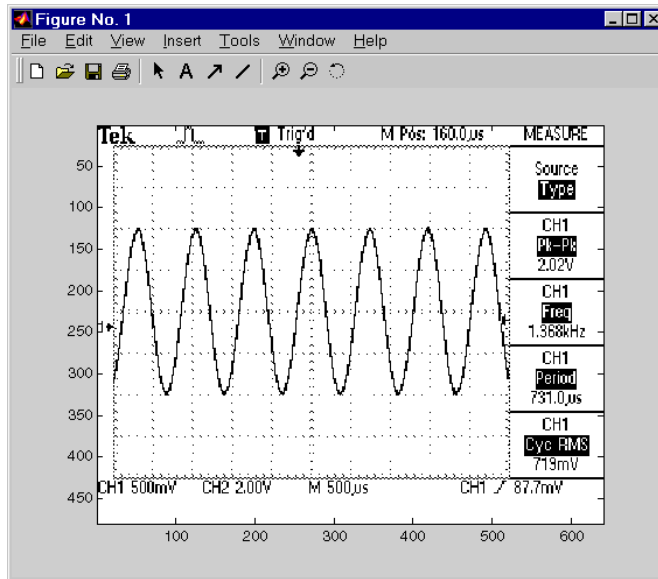

Events and Callbacks

You can enhance the power and flexibility of your serial port application by using *events*. An event occurs after a condition is met and might result in one or more callbacks.

While the serial port object is connected to the device, you can use events to display a message, display data, analyze data, and so on. Callbacks are controlled through *callback properties* and *callback functions*. All event types have an associated callback property. Callback functions are M-file functions that you construct to suit your specific application needs.

You execute a callback when a particular event occurs by specifying the name of the M-file callback function as the value for the associated callback property.

Example: Introduction to Events and Callbacks

This example uses the M-file callback function `instrcallback` to display a message to the command line when a bytes-available event occurs. The event is generated when the terminator is read.

```
s = serial('COM1');  
fopen(s)  
s.BytesAvailableFcnMode = 'terminator';  
s.BytesAvailableFcn = @instrcallback;  
fprintf(s, '*IDN?')  
out = fscanf(s);
```

The resulting display from `instrcallback` is shown below.

```
BytesAvailable event occurred at 17:01:29 for the object:  
Serial-COM1.
```

End the serial port session.

```
fclose(s)  
delete(s)  
clear s
```

You can use the `type` command to display `instrcallback` at the command line.

Event Types and Callback Properties

The serial port event types and callback properties are described below.

Table 10-9: Event Types and Callback Properties

Event Type	Associated Properties
Break interrupt	BreakInterruptFcn
Bytes available	BytesAvailableFcn
	BytesAvailableFcnCount
	BytesAvailableFcnMode
Error	ErrorFcn
Output empty	OutputEmptyFcn
Pin status	PinStatusFcn
Timer	TimerFcn
	TimerPeriod

Break-Interrupt Event. A break-interrupt event is generated immediately after a break interrupt is generated by the serial port. The serial port generates a break interrupt when the received data has been in an inactive state longer than the transmission time for one character.

This event executes the callback function specified for the `BreakInterruptFcn` property. It can be generated for both synchronous and asynchronous read and write operations.

Bytes-Available Event. A bytes-available event is generated immediately after a predetermined number of bytes are available in the input buffer or a terminator is read, as determined by the `BytesAvailableFcnMode` property.

If `BytesAvailableFcnMode` is `byte`, the bytes-available event executes the callback function specified for the `BytesAvailableFcn` property every time the number of bytes specified by `BytesAvailableFcnCount` is stored in the input

buffer. If `BytesAvailableFcnMode` is `terminator`, then the callback function executes every time the character specified by the `Terminator` property is read.

This event can be generated only during an asynchronous read operation.

Error Event. An error event is generated immediately after an error occurs.

This event executes the callback function specified for the `ErrorFcn` property. It can be generated only during an asynchronous read or write operation.

An error event is generated when a timeout occurs. A timeout occurs if a read or write operation does not successfully complete within the time specified by the `Timeout` property. An error event is not generated for configuration errors such as setting an invalid property value.

Output-Empty Event. An output-empty event is generated immediately after the output buffer is empty.

This event executes the callback function specified for the `OutputEmptyFcn` property. It can be generated only during an asynchronous write operation.

Pin Status Event. A pin status event is generated immediately after the state (pin value) changes for the CD, CTS, DSR, or RI pins. Refer to “Serial Port Signals and Pin Assignments” on page 10-7 for a description of these pins.

This event executes the callback function specified for the `PinStatusFcn` property. It can be generated for both synchronous and asynchronous read and write operations.

Timer Event. A timer event is generated when the time specified by the `TimerPeriod` property passes. Time is measured relative to when the serial port object is connected to the device.

This event executes the callback function specified for the `TimerFcn` property. Note that some timer events might not be processed if your system is significantly slowed or if the `TimerPeriod` value is too small.

Storing Event Information

You can store event information in a callback function or in a record file. Event information is stored in a callback function using two fields: `Type` and `Data`. The `Type` field contains the event type, while the `Data` field contains event-specific information. As described in “Creating and Executing Callback Functions” on

page 10-54, these two fields are associated with a structure that you define in the callback function header. Refer to “Debugging: Recording Information to Disk” on page 10-64 to learn about recording data and event information to a record file.

The event types and the values for the Type and Data fields are given below.

Table 10-10: Event Information

Event Type	Field	Field Value
Break interrupt	Type	BreakInterrupt
	Data.AbsTime	day-month-year hour:minute:second
Bytes available	Type	BytesAvailable
	Data.AbsTime	day-month-year hour:minute:second
Error	Type	Error
	Data.AbsTime	day-month-year hour:minute:second
	Data.Message	An error string
Output empty	Type	OutputEmpty
	Data.AbsTime	day-month-year hour:minute:second
Pin status	Type	PinStatus
	Data.AbsTime	day-month-year hour:minute:second
	Data.Pin	CarrierDetect, ClearToSend, DataSetReady, or RingIndicator
	Data.PinValue	on or off
Timer	Type	Timer
	Data.AbsTime	day-month-year hour:minute:second

The Data field values are described below.

The AbsTime Field. AbsTime is defined for all events, and indicates the absolute time the event occurred. The absolute time is returned using the clock format.

day-month-year hour:minute:second

The Pin Field. Pin is used by the pin status event to indicate if the CD, CTS, DSR, or RI pins changed state. Refer to “Serial Port Signals and Pin Assignments” on page 10-7 for a description of these pins.

The PinValue Field. PinValue is used by the pin status event to indicate the state of the CD, CTS, DSR, or RI pins. Possible values are on or off.

The Message Field. Message is used by the error event to store the descriptive message that is generated when an error occurs.

Creating and Executing Callback Functions

You can specify the callback function to be executed when a specific event type occurs by including the name of the M-file as the value for the associated callback property. You can specify the callback function as a function handle or as a string cell array element. Function handles are described in the `function_handle` reference pages.

For example, to execute the callback function `mycallback` every time the terminator is read from your device

```
s.BytesAvailableFcnMode = 'terminator';  
s.BytesAvailableFcn = @mycallback;
```

Alternatively, you can specify the callback function as a cell array.

```
s.BytesAvailableFcn = {'mycallback'};
```

M-file callback functions require at least two input arguments. The first argument is the serial port object. The second argument is a variable that captures the event information given in Table 10-10, Event Information, on page 10-53. This event information pertains only to the event that caused the callback function to execute. The function header for `mycallback` is shown below.

```
function mycallback(obj,event)
```

You pass additional parameters to the callback function by including both the callback function and the parameters as elements of a cell array. For example, to pass the MATLAB variable `time` to `mycallback`

```
time = datestr(now,0);  
s.BytesAvailableFcnMode = 'terminator';  
s.BytesAvailableFcn = {@mycallback,time};
```

Alternatively, you can specify the callback function as a string in the cell array.

```
s.BytesAvailableFcn = {'mycallback',time};
```

The corresponding function header is

```
function mycallback(obj,event,time)
```

If you pass additional parameters to the callback function, then they must be included in the function header after the two required arguments.

Note You can also specify the callback function as a string. In this case, the callback is evaluated in the MATLAB workspace and no requirements are made on the input arguments of the callback function.

Enabling Callback Functions After They Error

If an error occurs while a callback function is executing, then:

- The callback function is automatically disabled.
- A warning is displayed at the command line, indicating that the callback function is disabled.

If you want to enable the same callback function, you can set the callback property to the same value or you can disconnect the object with the `fclose` function. If you want to use a different callback function, the callback will be enabled when you configure the callback property to the new value.

Example: Using Events and Callbacks

This example uses the M-file callback function `instrcallback` to display event-related information to the command line when a bytes-available event or an output-empty event occurs.

- 1 Create a serial port object** – Create the serial port object `s` associated with serial port COM1.

```
s = serial('COM1');
```

- 2 Connect to the device** – Connect `s` to the Tektronix TDS 210 oscilloscope. Because the default value for the `ReadAsyncMode` property is `continuous`, data is asynchronously returned to the input buffer as soon as it is available from the instrument.

```
fopen(s)
```

- 3 Configure properties** – Configure `s` to execute the callback function `instrcallback` when a bytes-available event or an output-empty event occurs. Because `instrcallback` requires the serial port object and event information to be passed as input arguments, the callback function is specified as a function handle.

```
s.BytesAvailableFcnMode = 'terminator';  
s.BytesAvailableFcn = @instrcallback;  
s.OutputEmptyFcn = @instrcallback;
```

- 4 Write and read data** – Write the `RS232?` command asynchronously to the oscilloscope. This command queries the RS-232 settings and returns the baud rate, the software flow control setting, the hardware flow control setting, the parity type, and the terminator.

```
fprintf(s, 'RS232?', 'async')
```

`instrcallback` is called after the `RS232?` command is sent, and when the terminator is read. The resulting displays are shown below.

```
OutputEmpty event occurred at 17:37:21 for the object:  
Serial-COM1.
```

```
BytesAvailable event occurred at 17:37:21 for the object:  
Serial-COM1.
```

Read the data from the input buffer.

```
out = fscanf(s)
out =
9600;0;0;NONE;LF
```

- 5 Disconnect and clean up** – When you no longer need `s`, you should disconnect it from the instrument, and remove it from memory and from the MATLAB workspace.

```
fclose(s)
delete(s)
clear s
```

Using Control Pins

As described in “Serial Port Signals and Pin Assignments” on page 10-7, 9-pin serial ports include six control pins. These control pins allow you to:

- Signal the presence of connected devices
- Control the flow of data

The properties associated with the serial port control pins are given below.

Table 10-11: Control Pin Properties

Property Name	Description
DataTerminalReady	Specify the state of the DTR pin
FlowControl	Specify the data flow control method to use
PinStatus	Indicate the state of the CD, CTS, DSR, and RI pins
RequestToSend	Specify the state of the RTS pin

Signaling the Presence of Connected Devices

DTE's and DCE's often use the CD, DSR, RI, and DTR pins to indicate whether a connection is established between serial port devices. Once the connection is established, you can begin to write or read data.

You can monitor the state of the CD, DSR, and RI pins with the `PinStatus` property. You can specify or monitor the state of the DTR pin with the `DataTerminalReady` property.

The following example illustrates how these pins are used when two modems are connected to each other.

Example: Connecting Two Modems

This example connects two modems to each other via the same computer, and illustrates how you can monitor the communication status for the computer-modem connections, and for the modem-modem connection. The first modem is connected to COM1, while the second modem is connected to COM2.

- 1 Create the serial port objects** – After the modems are powered on, the serial port object `s1` is created for the first modem, and the serial port object `s2` is created for the second modem.

```
s1 = serial('COM1');  
s2 = serial('COM2');
```

- 2 Connect to the devices** – `s1` and `s2` are connected to the modems. Because the default value for the `ReadAsyncMode` property is `continuous`, data is asynchronously returned to the input buffers as soon as it is available from the modems.

```
fopen(s1)  
fopen(s2)
```

Because the default `DataTerminalReady` property value is `on`, the computer (data terminal) is now ready to exchange data with the modems. You can verify that the modems (data sets) can communicate with the computer by examining the value of the Data Set Ready pin with the `PinStatus` property.

```
s1.PinStatus  
ans =  
    CarrierDetect: 'off'  
    ClearToSend: 'on'  
    DataSetReady: 'on'  
    RingIndicator: 'off'
```

The value of the `DataSetReady` field is `on` because both modems were powered on before they were connected to the objects.

- 3 Configure properties** – Both modems are configured for a baud rate of 2400 bits per second and a carriage return (CR) terminator.

```
s1.BaudRate = 2400;  
s1.Terminator = 'CR';  
s2.BaudRate = 2400;  
s2.Terminator = 'CR';
```

- 4 Write and read data** – Write the `atd` command to the first modem. This command puts the modem “off the hook,” which is equivalent to manually lifting a phone receiver.

```
fprintf(s1,'atd')
```

Write the ata command to the second modem. This command puts the modem in “answer mode,” which forces it to connect to the first modem.

```
fprintf(s2, 'ata')
```

After the two modems negotiate their connection, you can verify the connection status by examining the value of the Carrier Detect pin using the PinStatus property.

```
s1.PinStatus
ans =
    CarrierDetect: 'on'
      ClearToSend: 'on'
    DataSetReady: 'on'
    RingIndicator: 'off'
```

You can also verify the modem-modem connection by reading the descriptive message returned by the second modem.

```
s2.BytesAvailable
ans =
    25
out = fread(s2,25);
char(out)
ans =
ata
CONNECT 2400/NONE
```

Now break the connection between the two modems by configuring the DataTerminalReady property to off. You can verify that the modems are disconnected by examining the Carrier Detect pin value.

```
s1.DataTerminalReady = 'off';
s1.PinStatus
ans =
    CarrierDetect: 'off'
      ClearToSend: 'on'
    DataSetReady: 'on'
    RingIndicator: 'off'
```

- 5 Disconnect and clean up** – Disconnect the objects from the modems, and remove the objects from memory and from the MATLAB workspace.

```
fclose([s1 s2])
delete([s1 s2])
clear s1 s2
```

Controlling the Flow of Data: Handshaking

Data flow control or *handshaking* is a method used for communicating between a DCE and a DTE to prevent data loss during transmission. For example, suppose your computer can receive only a limited amount of data before it must be processed. As this limit is reached, a handshaking signal is transmitted to the DCE to stop sending data. When the computer can accept more data, another handshaking signal is transmitted to the DCE to resume sending data.

If supported by your device, you can control data flow using one of these methods:

- Hardware handshaking
- Software handshaking

Note Although you might be able to configure your device for both hardware handshaking and software handshaking at the same time, MATLAB does not support this behavior.

You can specify the data flow control method with the `FlowControl` property. If `FlowControl` is `hardware`, then hardware handshaking is used to control data flow. If `FlowControl` is `software`, then software handshaking is used to control data flow. If `FlowControl` is `none`, then no handshaking is used.

Hardware Handshaking

Hardware handshaking uses specific serial port pins to control data flow. In most cases, these are the RTS and CTS pins. Hardware handshaking using these pins is described in “The RTS and CTS Pins” on page 10-11.

If `FlowControl` is `hardware`, then the RTS and CTS pins are automatically managed by the DTE and DCE. You can return the CTS pin value with the

PinStatus property. You can configure or return the RTS pin value with the RequestToSend property.

Note Some devices also use the DTR and DSR pins for handshaking. However, these pins are typically used to indicate that the system is ready for communication, and are not used to control data transmission. In MATLAB, hardware handshaking always uses the RTS and CTS pins.

If your device does not use hardware handshaking in the standard way, then you might need to manually configure the RequestToSend property. In this case, you should configure FlowControl to none. If FlowControl is hardware, then the RequestToSend value that you specify might not be honored. Refer to the device documentation to determine its specific pin behavior.

Software Handshaking

Software handshaking uses specific ASCII characters to control data flow. These characters, known as Xon and Xoff (or XON and XOFF), are described below.

Table 10-12: Software Handshaking Characters

Character	Integer Value	Description
Xon	17	Resume data transmission
Xoff	19	Pause data transmission

When using software handshaking, the control characters are sent over the transmission line the same way as regular data. Therefore you need only the TD, RD, and GND pins.

The main disadvantage of software handshaking is that you cannot write the Xon or Xoff characters while numerical data is being written to the device. This is because numerical data might contain a 17 or 19, which makes it impossible to distinguish between the control characters and the data. However, you can write Xon or Xoff while data is being asynchronously read from the device because you are using both the TD and RD pins.

Example: Using Software Handshaking

Suppose you want to use software flow control with the example described in “Example: Reading Binary Data” on page 10-46. To do this, you must configure the oscilloscope and serial port object for software flow control.

```
fprintf(s, 'RS232:SOFTF ON')  
s.FlowControl = 'software';
```

To pause data transfer, you write the numerical value 19 to the device.

```
fwrite(s,19)
```

To resume data transfer, you write the numerical value 17 to the device.

```
fwrite(s,17)
```

Debugging: Recording Information to Disk

While the serial port object is connected to the device, you can record this information to a disk file:

- The number of values written to the device, the number of values read from the device, and the data type of the values
- Data written to the device, and data read from the device
- Event information

Recording information to disk provides a permanent record of your serial port session, and is an easy way to debug your application.

You record information to a disk file with the record function. The properties associated with recording information to disk are given below.

Table 10-13: Recording Properties

Property Name	Description
RecordDetail	Specify the amount of information saved to a record file
RecordMode	Specify whether data and event information is saved to one record file or to multiple record files
RecordName	Specify the name of the record file
RecordStatus	Indicate if data and event information are saved to a record file

Example: Introduction to Recording Information

This example records the number of values written to and read from the device, and stores the information to the file `myfile.txt`

```
s = serial('COM1');
fopen(s)
s.RecordName = 'myfile.txt';
record(s)
fprintf(s, '*IDN?')
idn = fscanf(s);
```

```
fprintf(s, 'RS232?')
rs232 = fscanf(s);
```

End the serial port session.

```
fclose(s)
delete(s)
clear s
```

You can use the `type` command to display `myfile.txt` at the command line.

Creating Multiple Record Files

When you initiate recording with the `record` function, the `RecordMode` property determines if a new record file is created or if new information is appended to an existing record file.

You can configure `RecordMode` to overwrite, append, or index. If `RecordMode` is `overwrite`, then the record file is overwritten each time recording is initiated. If `RecordMode` is `append`, then the new information is appended to the file specified by `RecordName`. If `RecordMode` is `index`, a different disk file is created each time recording is initiated. The rules for specifying a record filename are discussed in the next section.

Specifying a Filename

You specify the name of the record file with the `RecordName` property. You can specify any value for `RecordName` – including a directory path – provided the filename is supported by your operating system. Additionally, if `RecordMode` is `index`, then the filename follows these rules:

- Indexed filenames are identified by a number. This number precedes the filename extension and is increased by 1 for successive record files.
- If no number is specified as part of the initial filename, then the first record file does not have a number associated with it. For example, if `RecordName` is `myfile.txt`, then `myfile.txt` is the name of the first record file, `myfile01.txt` is the name of the second record file, and so on.
- `RecordName` is updated after the record file is closed.
- If the specified filename already exists, then the existing file is overwritten.

The Record File Format

The record file is an ASCII file that contains a record of one or more serial port sessions. You specify the amount of information saved to a record file with the `RecordDetail` property.

`RecordDetail` can be compact or verbose. A compact record file contains the number of values written to the device, the number of values read from the device, the data type of the values, and event information. A verbose record file contains the preceding information as well as the data transferred to and from the device.

Binary data with precision given by `uchar`, `schar`, `(u)int8`, `(u)int16` or `(u)int32` is recorded using hexadecimal format. For example, if the integer value 255 is read from the instrument as a 16-bit integer, the hexadecimal value 00FF is saved in the record file. Single- and double-precision floating-point numbers are recorded as decimal values using the `%g` format, and as hexadecimal values using the format specified by the IEEE Standard 754-1985 for Binary Floating-Point Arithmetic.

The IEEE floating-point format includes three components: the sign bit, the exponent field, and the significand field. Single-precision floating-point values consist of 32 bits. The value is given by

$$\text{value} = (-1)^{\text{sign}}(2^{\text{exp}-127})(1.\text{significand})$$

Double-precision floating-point values consist of 64 bits. The value is given by

$$\text{value} = (-1)^{\text{sign}}(2^{\text{exp}-1023})(1.\text{significand})$$

The floating-point format component, and the associated single-precision and double-precision bits are given below.

Component	Single-Precision Bits	Double-Precision Bits
sign	1	1
exp	2-9	2-12
significand	10-32	13-64

Bit 1 is the left-most bit as stored in the record file.

Example: Recording Information to Disk

This example illustrates how to record information transferred between a serial port object and a Tektronix TDS 210 oscilloscope. Additionally, the structure of the resulting record file is presented.

- 1 Create the serial port object** – Create the serial port object `s` associated with the serial port COM1.

```
s = serial('COM1');
```

- 2 Connect to the device** – Connect `s` to the oscilloscope. Because the default value for the `ReadAsyncMode` property is continuous, data is asynchronously returned the input buffer as soon as it is available from the instrument.

```
fopen(s)
```

- 3 Configure property values** – Configure `s` to record information to multiple disk files using the verbose format. Recording is then initiated with the first disk file defined as `WaveForm1.txt`.

```
s.RecordMode = 'index';
s.RecordDetail = 'verbose';
s.RecordName = 'WaveForm1.txt';
record(s)
```

- 4 Write and read data** – The commands written to the instrument, and the data read from the instrument are recorded in the record file. Refer to “Example: Writing and Reading Text Data” on page 10-44 for an explanation of the oscilloscope commands.

```
fprintf(s, '*IDN?')
idn = fscanf(s);
fprintf(s, 'MEASUREMENT:IMMED:SOURCE CH2')
fprintf(s, 'MEASUREMENT:IMMED:SOURCE?')
source = fscanf(s);
```

Read the peak-to-peak voltage with the `fread` function. Note that the data returned by `fread` is recorded using hex format.

```
fprintf(s, 'MEASUREMENT:MEAS1:TYPE PK2PK')
fprintf(s, 'MEASUREMENT:MEAS1:VALUE?')
ptop = fread(s,s.BytesAvailable);
```

Convert the peak-to-peak voltage to a character array.

```
char(ptop) '  
ans =  
2.0199999809E0
```

The recording state is toggled from on to off. Because the RecordMode value is index, the record filename is automatically updated.

```
record(s)  
s.RecordStatus  
ans =  
off  
s.RecordName  
ans =  
WaveForm2.txt
```

5 Disconnect and clean up – When you no longer need `s`, you should disconnect it from the instrument, and remove it from memory and from the MATLAB workspace.

```
fclose(s)  
delete(s)  
clear s
```

The Record File Contents

The contents of the WaveForm1.txt record file are shown below. Because the RecordDetail property was verbose, the number of values, commands, and data were recorded. Note that data returned by the fread function is in hex format.

```
type WaveForm1.txt
```

Legend:

- * - An event occurred.
- > - A write operation occurred.
- < - A read operation occurred.

```
1   Recording on 22-Jan-2000 at 11:21:21.575. Binary data in...
2   > 6 ascii values.
    *IDN?
3   < 56 ascii values.
    TEKTRONIX,TDS 210,0,CF:91.1CT FV:v1.16 TDS2CM:CMV:v1.04
4   > 29 ascii values.
    MEASUREMENT:IMMED:SOURCE CH2
5   > 26 ascii values.
    MEASUREMENT:IMMED:SOURCE?
6   < 4 ascii values.
    CH2
7   > 27 ascii values.
    MEASUREMENT:MEAS1:TYPE PK2PK
8   > 25 ascii values.
    MEASUREMENT:MEAS1:VALUE?
9   < 15 uchar values.
    32 2e 30 31 39 39 39 39 38 30 39 45 30 0a
10  Recording off.
```

Saving and Loading

You can save serial port objects to a MAT-file just as you would any workspace variable – using the `save` command. For example, suppose you create the serial port object `s` associated with the serial port `COM1`, configure several property values, and perform a write and read operation.

```
s = serial('COM1');
s.BaudRate = 19200;
s.Tag = 'My serial object';
fopen(s)
fprintf(s, '*IDN?')
out = fscanf(s);
```

To save the serial port object and the data read from the device to the MAT-file `myserial.mat`

```
save myserial s out
```

Note You can save data and event information as text to a disk file with the `record` function.

You can recreate `s` and `out` in the workspace using the `load` command.

```
load myserial
```

Values for read-only properties are restored to their default values upon loading. For example, the `Status` property is restored to `closed`. Therefore, to use `s`, you must connect it to the device with the `fopen` function. To determine if a property is read-only, examine its reference pages.

Using Serial Port Objects on Different Platforms

If you save a serial port object from one platform, and then load that object on a different platform having different serial port names, then you will need to modify the `Port` property value. For example, suppose you create the serial port object `s` associated with the serial port `COM1` on a Windows platform. If you want to save `s` for eventual use on a Linux platform, you should configure `Port` to an appropriate value such as `ttyS0` after the object is loaded.

Disconnecting and Cleaning Up

When you no longer need your serial port object, you should disconnect it from the device, and clean up your MATLAB environment by removing the object from memory and from the workspace. These are the steps you take to end a serial port session.

Disconnecting a Serial Port Object

When you no longer need to communicate with the device, you should disconnect it from the serial port object with the `fclose` function.

```
fclose(s)
```

You can examine the `Status` property to verify that the serial port object and the device are disconnected.

```
s.Status  
ans =  
closed
```

After `fclose` is issued, the serial port associated with `s` is available. You can now connect another serial port object to it using `fopen`.

Cleaning Up the MATLAB Environment

When you no longer need the serial port object, you should remove it from memory with the `delete` function.

```
delete(s)
```

Before using `delete`, you must disconnect the serial port object from the device with the `fclose` function.

A deleted serial port object is *invalid*, which means that you cannot connect it to the device. In this case, you should remove the object from the MATLAB workspace. To remove serial port objects and other variables from the MATLAB workspace, use the `clear` command.

```
clear s
```

If you use `clear` on a serial port object that is still connected to a device, the object is removed from the workspace but remains connected to the device. You can restore cleared objects to MATLAB with the `instrfind` function.

Property Reference

This section includes information to help you learn about serial port properties. The information is organized using these topics:

- “The Property Reference Page Format” on page 10-72 describes the organization of the property reference pages.
- “Serial Port Object Properties” on page 10-73 summarizes the properties using several categories based on how they are used. Following this section, the properties are listed alphabetically and described in detail.

The Property Reference Page Format

Each serial port property description contains some or all of this information:

- The property name
- A description of the property
- The property characteristics, including:
 - Read only – the condition under which the property is read only
A property can be read only always, never, while the serial port object is open, or while the serial port object is recording. You can configure a property value using the set function or dot notation. You can return the current property value using the get function or dot notation.
 - Data type – the property data type
This is the data type you use when specifying a property value.
- Valid property values including the default value
When property values are given by a predefined list, the default value is usually indicated by {}.
- An example using the property
- Related properties and functions

Serial Port Object Properties

The serial port object properties are briefly described below, and organized into categories based on how they are used. Following this section, the properties are listed alphabetically and described in detail.

Communications Properties

BaudRate	Specify the rate at which bits are transmitted
DataBits	Specify the number of data bits to transmit
Parity	Specify the type of parity checking
StopBits	Specify the number of bits used to indicate the end of a byte
Terminator	Specify the terminator character

Write Properties

BytesToOutput	Indicate the number of bytes currently in the output buffer
OutputBufferSize	Specify the size of the output buffer in bytes
Timeout	Specify the waiting time to complete a read or write operation
TransferStatus	Indicate if an asynchronous read or write operation is in progress
ValuesSent	Indicate the total number of values written to the device

Read Properties	
BytesAvailable	Indicate the number of bytes available in the input buffer
InputBufferSize	Specify the size of the input buffer in bytes
ReadAsyncMode	Specify whether an asynchronous read operation is continuous or manual
Timeout	Specify the waiting time to complete a read or write operation
TransferStatus	Indicate if an asynchronous read or write operation is in progress
ValuesReceived	Indicate the total number of values read from the device

Callback Properties	
BreakInterrupt Fcn	Specify the M-file callback function to execute when a break-interrupt event occurs
BytesAvailable Fcn	Specify the M-file callback function to execute when a specified number of bytes is available in the input buffer, or a terminator is read
BytesAvailable FcnCount	Specify the number of bytes that must be available in the input buffer to generate a bytes-available event
BytesAvailable FcnMode	Specify if the bytes-available event is generated after a specified number of bytes is available in the input buffer, or after a terminator is read
ErrorFcn	Specify the M-file callback function to execute when an error event occurs

Callback Properties (Continued)

OutputEmptyFcn	Specify the M-file callback function to execute when the output buffer is empty
PinStatusFcn	Specify the M-file callback function to execute when the CD, CTS, DSR, or RI pins change state
TimerFcn	Specify the M-file callback function to execute when a predefined period of time passes
TimerPeriod	Specify the period of time between timer events

Control Pin Properties

DataTerminalReady	Specify the state of the DTR pin
FlowControl	Specify the data flow control method to use
PinStatus	Indicate the state of the CD, CTS, DSR, and RI pins
RequestToSend	Specify the state of the RTS pin

Recording Properties

RecordDetail	Specify the amount of information saved to a record file
RecordMode	Specify whether data and event information are saved to one record file or to multiple record files
RecordName	Specify the name of the record file
RecordStatus	Indicate if data and event information are saved to a record file

General Purpose Properties	
ByteOrder	Specify the order in which the device stores bytes
Name	Specify a descriptive name for the serial port object
Port	Indicate the platform-specific serial port name
Status	Indicate if the serial port object is connected to the device
Tag	Specify a label to associate with a serial port object
Type	Indicate the object type
UserData	Specify data that you want to associate with a serial port object

Purpose Specify the rate at which bits are transmitted

Description You configure BaudRate as bits per second. The transferred bits include the start bit, the data bits, the parity bit (if used), and the stop bits. However, only the data bits are stored.

The baud rate is the rate at which information is transferred in a communication channel. In the serial port context, "9600 baud" means that the serial port is capable of transferring a maximum of 9600 bits per second. If the information unit is one baud (one bit), then the bit rate and the baud rate are identical. If one baud is given as 10 bits, (for example, eight data bits plus two framing bits), the bit rate is still 9600 but the baud rate is 9600/10, or 960. You always configure BaudRate as bits per second. Therefore, in the above example, set BaudRate to 9600.

Note Both the computer and the peripheral device must be configured to the same baud rate before you can successfully read or write data.

Standard baud rates include 110, 300, 600, 1200, 2400, 4800, 9600, 14400, 19200, 38400, 57600, 115200, 128000 and 256000 bits per second. To display the supported baud rates for the serial ports on your platform, refer to "Finding Serial Port Information for Your Platform" on page 10-16.

Characteristics

Read only	Never
Data type	Double

Values The default value is 9600.

See Also **Properties**
DataBits, Parity, StopBits

BreakInterruptFcn

Purpose Specify the M-file callback function to execute when a break-interrupt event occurs

Description You configure BreakInterruptFcn to execute an M-file callback function when a break-interrupt event occurs. A break-interrupt event is generated by the serial port when the received data is in an off (space) state longer than the transmission time for one byte.

Note A break-interrupt event can be generated at any time during the serial port session.

If the RecordStatus property value is on, and a break-interrupt event occurs, the record file records this information:

- The event type as BreakInterrupt
- The time the event occurred using the format day-month-year hour:minute:second:millisecond

Refer to “Creating and Executing Callback Functions” on page 10-54 to learn how to create a callback function.

Characteristics

Read only	Never
Data type	Callback function

Values The default value is an empty string.

See Also **Functions**
record

Properties
RecordStatus

Purpose Specify the byte order of the device

Description You configure `ByteOrder` to be `littleEndian` or `bigEndian`. If `ByteOrder` is `littleEndian`, then the device stores the first byte in the first memory address. If `ByteOrder` is `bigEndian`, then the device stores the last byte in the first memory address.

For example, suppose the hexadecimal value `4F52` is to be stored in device memory. Because this value consists of two bytes, `4F` and `52`, two memory locations are used. Using big-endian format, `4F` is stored first in the lower storage address. Using little-endian format, `52` is stored first in the lower storage address.

Note You should configure `ByteOrder` to the appropriate value for your device before performing a read or write operation. Refer to your device documentation for information about the order in which it stores bytes.

Characteristics

Read only	Never
Data type	String

Values

<code>{littleEndian}</code>	The byte order of the device is little-endian.
<code>bigEndian</code>	The byte order of the device is big-endian.

See Also

Properties
Status

BytesAvailable

Purpose Indicate the number of bytes available in the input buffer

Description BytesAvailable indicates the number of bytes currently available to be read from the input buffer. The property value is continuously updated as the input buffer is filled, and is set to 0 after the fopen function is issued.

You can make use of BytesAvailable only when reading data asynchronously. This is because when reading data synchronously, control is returned to the MATLAB command line only after the input buffer is empty. Therefore, the BytesAvailable value is always 0. Refer to “Reading Text Data” on page 10-41 to learn how to read data asynchronously.

The BytesAvailable value can range from zero to the size of the input buffer. Use the InputBufferSize property to specify the size of the input buffer. Use the ValuesReceived property to return the total number of values read.

Characteristics

Read only	Always
Data type	Double

Values The default value is 0.

See Also **Functions**
fopen

Properties
InputBufferSize, TransferStatus, ValuesReceived

Purpose Specify the M-file callback function to execute when a specified number of bytes is available in the input buffer, or a terminator is read

Description You configure BytesAvailableFcn to execute an M-file callback function when a bytes-available event occurs. A bytes-available event occurs when the number of bytes specified by the BytesAvailableFcnCount property is available in the input buffer, or after a terminator is read, as determined by the BytesAvailableFcnMode property.

Note A bytes-available event can be generated only for asynchronous read operations.

If the RecordStatus property value is on, and a bytes-available event occurs, the record file records this information:

- The event type as BytesAvailable
- The time the event occurred using the format day-month-year
hour:minute:second:millisecond

Refer to “Creating and Executing Callback Functions” on page 10-54 to learn how to create a callback function.

Characteristics

Read only	Never
Data type	Callback function

Values The default value is an empty string.

Example Create the serial port object s for a Tektronix TDS 210 two-channel oscilloscope connected to the serial port COM1.

```
s = serial('COM1');
```

BytesAvailableFcn

Configure `s` to execute the M-file callback function `instrcallback` when 40 bytes are available in the input buffer.

```
s.BytesAvailableFcnCount = 40;  
s.BytesAvailableFcnMode = 'byte';  
s.BytesAvailableFcn = @instrcallback;
```

Connect `s` to the oscilloscope.

```
fopen(s)
```

Write the `*IDN?` command, which instructs the scope to return identification information. Because the default value for the `ReadAsyncMode` property is `continuous`, data is read as soon as it is available from the instrument.

```
fprintf(s, '*IDN?')
```

The resulting output from `instrcallback` is shown below.

```
BytesAvailable event occurred at 18:33:35 for the object:  
Serial-COM1.
```

56 bytes are read and `instrcallback` is called once. The resulting display is shown above.

```
s.BytesAvailable  
ans =  
    56
```

Suppose you remove 25 bytes from the input buffer and then issue the `MEASUREMENT?` command, which instructs the scope to return its measurement settings.

```
out = fscanf(s, '%c', 25);  
fprintf(s, 'MEASUREMENT?')
```

The resulting output from `instrcallback` is shown below.

```
BytesAvailable event occurred at 18:33:48 for the object:  
Serial-COM1.
```

```
BytesAvailable event occurred at 18:33:48 for the object:  
Serial-COM1.
```

There are now 102 bytes in the input buffer, 31 of which are left over from the *IDN? command. `instrcallback` is called twice; once when 40 bytes are available and once when 80 bytes are available.

```
s.BytesAvailable
ans =
    102
```

See Also

Functions

`record`

Properties

`BytesAvailableFcnCount`, `BytesAvailableFcnMode`, `RecordStatus`, `Terminator`, `TransferStatus`

BytesAvailableFcnCount

Purpose	Specify the number of bytes that must be available in the input buffer to generate a bytes-available event				
Description	<p>You configure BytesAvailableFcnCount to the number of bytes that must be available in the input buffer before a bytes-available event is generated.</p> <p>Use the BytesAvailableFcnMode property to specify whether the bytes-available event occurs after a certain number of bytes are available or after a terminator is read.</p> <p>The bytes-available event executes the M-file callback function specified for the BytesAvailableFcn property.</p> <p>You can configure BytesAvailableFcnCount only when the object is disconnected from the device. You disconnect an object with the fclose function. A disconnected object has a Status property value of closed.</p>				
Characteristics	<table><tr><td>Read only</td><td>While open</td></tr><tr><td>Data type</td><td>Double</td></tr></table>	Read only	While open	Data type	Double
Read only	While open				
Data type	Double				
Values	The default value is 48.				
See Also	Functions fclose Properties BytesAvailableFcn, BytesAvailableFcnMode, Status				

Purpose

Specify if the bytes-available event is generated after a specified number of bytes is available in the input buffer, or after a terminator is read

Description

You can configure BytesAvailableFcnMode to be terminator or byte. If BytesAvailableFcnMode is terminator, a bytes-available event occurs when the terminator specified by the Terminator property is reached. If BytesAvailableFcnMode is byte, a bytes-available event occurs when the number of bytes specified by the BytesAvailableFcnCount property is available.

The bytes-available event executes the M-file callback function specified for the BytesAvailableFcn property.

You can configure BytesAvailableFcnMode only when the object is disconnected from the device. You disconnect an object with the fclose function. A disconnected object has a Status property value of closed.

Characteristics

Read only While open

Data type String

Values

{terminator} A bytes-available event is generated when the terminator is read.

byte A bytes-available event is generated when the specified number of bytes are available.

See Also

Functions

fclose

Properties

BytesAvailableFcn, BytesAvailableFcnCount, Status, Terminator

BytesToOutput

Purpose Indicate the number of bytes currently in the output buffer

Description BytesToOutput indicates the number of bytes currently in the output buffer waiting to be written to the device. The property value is continuously updated as the output buffer is filled and emptied, and is set to 0 after the fopen function is issued.

You can make use of BytesToOutput only when writing data asynchronously. This is because when writing data synchronously, control is returned to the MATLAB command line only after the output buffer is empty. Therefore, the BytesToOutput value is always 0. Refer to “Writing Text Data” on page 10-35 to learn how to write data asynchronously.

Use the ValuesSent property to return the total number of values written to the device.

Note If you attempt to write out more data than can fit in the output buffer, then an error is returned and BytesToOutput is 0. You specify the size of the output buffer with the OutputBufferSize property.

Characteristics

Read only	Always
Data type	Double

Values The default value is 0.

See Also **Functions**
fopen

Properties
OutputBufferSize, TransferStatus, ValuesSent

Purpose Specify the number of data bits to transmit

Description You can configure DataBits to be 5, 6, 7, or 8. Data is transmitted as a series of five, six, seven, or eight bits with the least significant bit sent first. At least seven data bits are required to transmit ASCII characters. Eight bits are required to transmit binary data. Five and six bit data formats are used for specialized communications equipment.

Note Both the computer and the peripheral device must be configured to transmit the same number of data bits.

In addition to the data bits, the serial data format consists of a start bit, one or two stop bits, and possibly a parity bit. You specify the number of stop bits with the StopBits property, and the type of parity checking with the Parity property.

To display the supported number of data bits for the serial ports on your platform, refer to “Finding Serial Port Information for Your Platform” on page 10-16.

Characteristics

Read only	Never
Data type	Double

Values DataBits can be 5, 6, 7, or 8. The default value is 8.

See Also **Properties**
Parity, StopBits

DataTerminalReady

Purpose Specify the state of the DTR pin

Description You can configure `DataTerminalReady` to be on or off. If `DataTerminalReady` is on, the Data Terminal Ready (DTR) pin is asserted. If `DataTerminalReady` is off, the DTR pin is unasserted.

In normal usage, the DTR and Data Set Ready (DSR) pins work together, and are used to signal if devices are connected and powered. However, there is nothing in the RS-232 standard that states the DTR pin must be used in any specific way. For example, DTR and DSR might be used for handshaking. You should refer to your device documentation to determine its specific pin behavior.

You can return the value of the DSR pin with the `PinStatus` property. Handshaking is described in “Controlling the Flow of Data: Handshaking” on page 10-61.

Characteristics

Read only	Never
Data type	String

Values

{on}	The DTR pin is asserted.
off	The DTR pin is unasserted.

See Also **Properties**
`FlowControl`, `PinStatus`

Purpose Specify the M-file callback function to execute when an error event occurs

Description You configure ErrorFcn to execute an M-file callback function when an error event occurs.

Note An error event is generated only for asynchronous read and write operations.

An error event is generated when a timeout occurs. A timeout occurs if a read or write operation does not successfully complete within the time specified by the Timeout property. An error event is not generated for configuration errors such as setting an invalid property value.

If the RecordStatus property value is on, and an error event occurs, the record file records this information:

- The event type as Error
- The error message
- The time the event occurred using the format day-month-year
hour:minute:second:millisecond

Refer to “Creating and Executing Callback Functions” on page 10-54 to learn how to create a callback function.

Characteristics

Read only	Never
Data type	Callback function

Values The default value is an empty string.

See Also **Functions**
record

Properties
RecordStatus, Timeout

FlowControl

Purpose Specify the data flow control method to use

Description You can configure FlowControl to be none, hardware, or software. If FlowControl is none, then data flow control (handshaking) is not used. If FlowControl is hardware, then hardware handshaking is used to control data flow. If FlowControl is software, then software handshaking is used to control data flow.

Hardware handshaking typically utilizes the Request to Send (RTS) and Clear to Send (CTS) pins to control data flow. Software handshaking uses control characters (Xon and Xoff) to control data flow. Refer to “Controlling the Flow of Data: Handshaking” on page 10-61 for more information about handshaking.

You can return the value of the CTS pin with the PinStatus property. You can specify the value of the RTS pin with the RequestToSend property. However, if FlowControl is hardware, and you specify a value for RequestToSend, then that value might not be honored.

Note Although you might be able to configure your device for both hardware handshaking and software handshaking at the same time, MATLAB does not support this behavior.

Characteristics

Read only	Never
Data type	String

Values

{none}	No flow control is used.
hardware	Hardware flow control is used.
software	Software flow control is used.

See Also **Properties**
PinStatus, RequestToSend

Purpose Specify the size of the input buffer in bytes

Description You configure `InputBufferSize` as the total number of bytes that can be stored in the input buffer during a read operation.

A read operation is terminated if the amount of data stored in the input buffer equals the `InputBufferSize` value. You can read text data with the `fgetl`, `fgets`, or `fscanf` functions. You can read binary data with the `fread` function.

You can configure `InputBufferSize` only when the serial port object is disconnected from the device. You disconnect an object with the `fclose` function. A disconnected object has a `Status` property value of `closed`.

If you configure `InputBufferSize` while there is data in the input buffer, then that data is flushed.

Characteristics

Read only	While open
Data type	Double

Values The default value is 512.

See Also

Functions
`fclose`, `fgetl`, `fgets`, `fopen`, `fread`, `fscanf`

Properties
`Status`

Name

Purpose Specify a descriptive name for the serial port object

Description You configure Name to be a descriptive name for the serial port object.

When you create a serial port object, a descriptive name is automatically generated and stored in Name. This name is given by concatenating the word “Serial” with the serial port specified in the serial function. However, you can change the value of Name at any time.

The serial port is given by the Port property. If you modify this property value, then Name is automatically updated to reflect that change.

Characteristics

Read only	Never
Data type	String

Values Name is automatically defined when the serial port object is created.

Example Suppose you create a serial port object associated with the serial port COM1.

```
s = serial('COM1');
```

s is automatically assigned a descriptive name.

```
s.Name  
ans =  
Serial-COM1
```

See Also

Functions
serial

Purpose Specify the size of the output buffer in bytes

Description You configure `OutputBufferSize` as the total number of bytes that can be stored in the output buffer during a write operation.

An error occurs if the output buffer cannot hold all the data to be written. You write text data with the `fprintf` function. You write binary data with the `fwrite` function.

You can configure `OutputBufferSize` only when the serial port object is disconnected from the device. You disconnect an object with the `fclose` function. A disconnected object has a `Status` property value of `closed`.

Characteristics

Read only	While open
Data type	Double

Values The default value is 512.

See Also

Functions
`fprintf`, `fwrite`

Properties
`Status`

OutputEmptyFcn

Purpose Specify the M-file callback function to execute when the output buffer is empty

Description You configure OutputEmptyFcn to execute an M-file callback function when an output-empty event occurs. An output-empty event is generated when the last byte is sent from the output buffer to the device.

Note An output-empty event can be generated only for asynchronous write operations.

If the RecordStatus property value is on, and an output-empty event occurs, the record file records this information:

- The event type as OutputEmpty
- The time the event occurred using the format day-month-year
hour:minute:second:millisecond

Refer to “Creating and Executing Callback Functions” on page 10-54 to learn how to create a callback function.

Characteristics

Read only	Never
Data type	Callback function

Values The default value is an empty string.

See Also **Functions**
record

Properties
RecordStatus

Purpose Specify the type of parity checking

Description You can configure Parity to be none, odd, even, mark, or space. If Parity is none, parity checking is not performed and the parity bit is not transmitted. If Parity is odd, the number of mark bits (1's) in the data is counted, and the parity bit is asserted or unasserted to obtain an odd number of mark bits. If Parity is even, the number of mark bits in the data is counted, and the parity bit is asserted or unasserted to obtain an even number of mark bits. If Parity is mark, the parity bit is asserted. If Parity is space, the parity bit is unasserted.

Parity checking can detect errors of one bit only. An error in two bits might cause the data to have a seemingly valid parity, when in fact it is incorrect. Refer to “The Parity Bit” on page 10-15 for more information about parity checking.

In addition to the parity bit, the serial data format consists of a start bit, between five and eight data bits, and one or two stop bits. You specify the number of data bits with the DataBits property, and the number of stop bits with the StopBits property.

Characteristics	Read only	Never
	Data type	String

Values	{none}	No parity checking
	odd	Odd parity checking
	even	Even parity checking
	mark	Mark parity checking
	space	Space parity checking

See Also **Properties**
DataBits, StopBits

PinStatus

Purpose Indicate the state of the CD, CTS, DSR, and RI pins

Description PinStatus is a structure array that contains the fields CarrierDetect, ClearToSend, DataSetReady and RingIndicator. These fields indicate the state of the Carrier Detect (CD), Clear to Send (CTS), Data Set Ready (DSR) and Ring Indicator (RI) pins, respectively. Refer to “Serial Port Signals and Pin Assignments” on page 10-7 for more information about these pins.

PinStatus can be on or off for any of these fields. A value of on indicates the associated pin is asserted. A value of off indicates the associated pin is unasserted. A pin status event occurs when any of these pins changes its state. A pin status event executes the M-file specified by PinStatusFcn.

In normal usage, the Data Terminal Ready (DTR) and DSR pins work together, while the Request to Send (RTS) and CTS pins work together. You can specify the state of the DTR pin with the DataTerminalReady property. You can specify the state of the RTS pin with the RequestToSend property.

Refer to “Example: Connecting Two Modems” on page 10-58 for an example that uses PinStatus.

Characteristics

Read only	Always
Data type	Structure

Values

off	The associated pin is asserted.
on	The associated pin is asserted.

The default value is device dependent.

See Also **Properties**
DataTerminalReady, PinStatusFcn, RequestToSend

Purpose Specify the M-file callback function to execute when the CD, CTS, DSR, or RI pins change state

Description You configure PinStatusFcn to execute an M-file callback function when a pin status event occurs. A pin status event occurs when the Carrier Detect (CD), Clear to Send (CTS), Data Set Ready (DSR) or Ring Indicator (RI) pin changes state. A serial port pin changes state when it is asserted or unasserted. Information about the state of these pins is recorded in the PinStatus property.

Note A pin status event can be generated at any time during the serial port session.

If the RecordStatus property value is on, and a pin status event occurs, the record file records this information:

- The event type as PinStatus
- The pin that changed its state, and the pin state as either on or off
- The time the event occurred using the format day-month-year hour:minute:second:millisecond

Refer to “Creating and Executing Callback Functions” on page 10-54 to learn how to create a callback function.

Characteristics

Read only	Never
Data type	Callback function

Values The default value is an empty string.

See Also **Functions**
record

Properties
PinStatus, RecordStatus

Port

Purpose

Specify the platform-specific serial port name

Description

You configure `Port` to be the name of a serial port on your platform. `Port` specifies the physical port associated with the object and the device.

When you create a serial port object, `Port` is automatically assigned the port name specified for the `serial` function.

You can configure `Port` only when the object is disconnected from the device. You disconnect an object with the `fclose` function. A disconnected object has a `Status` property value of `closed`.

Characteristics

Read only While open

Data type String

Values

The `Port` value is determined when the serial port object is created.

Example

Suppose you create a serial port object associated with serial port `COM1`.

```
s = serial('COM1');
```

The value of the `Port` property is `COM1`.

```
s.Port  
ans =  
COM1
```

See Also

Functions

`fclose`, `serial`

Properties

`Name`, `Status`

Purpose Specify whether an asynchronous read operation is continuous or manual

Description You can configure `ReadAsyncMode` to be continuous or manual. If `ReadAsyncMode` is continuous, the serial port object continuously queries the device to determine if data is available to be read. If data is available, it is automatically read and stored in the input buffer. If issued, the `readasync` function is ignored.

If `ReadAsyncMode` is manual, the object will not query the device to determine if data is available to be read. Instead, you must manually issue the `readasync` function to perform an asynchronous read operation. Because `readasync` checks for the terminator, this function can be slow. To increase speed, you should configure `ReadAsyncMode` to continuous.

Note If the device is ready to transmit data, then it will do so regardless of the `ReadAsyncMode` value. Therefore, if `ReadAsyncMode` is manual and a read operation is not in progress, then data might be lost. To guarantee that all transmitted data is stored in the input buffer, you should configure `ReadAsyncMode` to continuous.

You can determine the amount of data available in the input buffer with the `BytesAvailable` property. For either `ReadAsyncMode` value, you can bring data into the MATLAB workspace with one of the synchronous read functions such as `fscanf`, `fgetl`, `fgets`, or `fread`.

Characteristics

Read only	Never
Data type	String

Values

<code>{continuous}</code>	Continuously query the device to determine if data is available to be read.
<code>manual</code>	Manually read data from the device using the <code>readasync</code> function.

ReadAsyncMode

See Also

Functions

fgetc1, fgets, fread, fscanf, readasync

Properties

BytesAvailable, InputBufferSize

Purpose Specify the amount of information saved to a record file

Description You can configure RecordDetail to be compact or verbose. If RecordDetail is compact, the number of values written to the device, the number of values read from the device, the data type of the values, and event information are saved to the record file. If RecordDetail is verbose, the data written to the device, and the data read from the device are also saved to the record file.

The event information saved to a record file is shown in Table 10-10, Event Information, on page 10-53. The verbose record file structure is shown in “Example: Recording Information to Disk” on page 10-67.

Characteristics	Read only	Never
	Data type	String

Values	{compact}	The number of values written to the device, the number of values read from the device, the data type of the values, and event information are saved to the record file.
	verbose	The data written to the device, and the data read from the device are also saved to the record file.

See Also **Functions**
record

Properties
RecordMode, RecordName, RecordStatus

RecordMode

Purpose Specify whether data and event information are saved to one record file or to multiple record files

Description You can configure RecordMode to be overwrite, append, or index. If RecordMode is overwrite, then the record file is overwritten each time recording is initiated. If RecordMode is append, then data is appended to the record file each time recording is initiated. If RecordMode is index, a different record file is created each time recording is initiated, each with an indexed filename.

You can configure RecordMode only when the object is not recording. You terminate recording with the record function. A object that is not recording has a RecordStatus property value of off.

You specify the record filename with the RecordName property. The indexed filename follows a prescribed set of rules. Refer to “Specifying a Filename” on page 10-65 for a description of these rules.

Characteristics	Read only	While recording
	Data type	String

Values	{overwrite}	The record file is overwritten.
	append	Data is appended to an existing record file.
	index	A different record file is created, each with an indexed filename.

Example Suppose you create the serial port object s associated with the serial port COM1.

```
s = serial('COM1');  
fopen(s)
```

Specify the record filename with the RecordName property, configure RecordMode to index, and initiate recording.

```
s.RecordName = 'MyRecord.txt';  
s.RecordMode = 'index';  
record(s)
```

The record filename is automatically updated with an indexed filename after recording is turned off.

```
record(s, 'off')
s.RecordName
ans =
MyRecord01.txt
```

Disconnect `s` from the peripheral device, remove `s` from memory, and remove `s` from the MATLAB workspace.

```
fclose(s)
delete(s)
clear s
```

See Also

Functions

`record`

Properties

`RecordDetail`, `RecordName`, `RecordStatus`

RecordName

Purpose Specify the name of the record file

Description You configure RecordName to be the name of the record file. You can specify any value for RecordName – including a directory path – provided the filename is supported by your operating system.

MATLAB supports any filename supported by your operating system. However, if you access the file through MATLAB, you might need to specify the filename using single quotes. For example, suppose you name the record file My Record.txt. To type this file at the MATLAB command line, you must include the name in quotes.

```
type('My Record.txt')
```

You can specify whether data and event information are saved to one disk file or to multiple disk files with the RecordMode property. If RecordMode is index, then the filename follows a prescribed set of rules. Refer to “Specifying a Filename” on page 10-65 for a description of these rules.

You can configure RecordName only when the object is not recording. You terminate recording with the record function. An object that is not recording has a RecordStatus property value of off.

Characteristics

Read only	While recording
Data type	String

Values The default record filename is record.txt.

See Also **Functions**
record

Properties
RecordDetail, RecordMode, RecordStatus

Purpose	Indicate if data and event information are saved to a record file	
Description	<p>You can configure RecordStatus to be off or on with the record function. If RecordStatus is off, then data and event information are not saved to a record file. If RecordStatus is on, then data and event information are saved to the record file specified by RecordName.</p> <p>Use the record function to initiate or complete recording. RecordStatus is automatically configured to reflect the recording state.</p> <p>For more information about recording to a disk file, refer to “Debugging: Recording Information to Disk” on page 10-64.</p>	
Characteristics	Read only	Always
	Data type	String
Values	{off}	Data and event information are not written to a record file.
	on	Data and event information are written to a record file.
See Also	Functions	
	record	
	Properties	
	RecordDetail, RecordMode, RecordName	

RequestToSend

Purpose Specify the state of the RTS pin

Description You can configure `RequestToSend` to be on or off. If `RequestToSend` is on, the Request to Send (RTS) pin is asserted. If `RequestToSend` is off, the RTS pin is unasserted.

In normal usage, the RTS and Clear to Send (CTS) pins work together, and are used as standard handshaking pins for data transfer. In this case, RTS and CTS are automatically managed by the DTE and DCE. However, there is nothing in the RS-232 standard that requires the RTS pin must be used in any specific way. Therefore, if you manually configure the `RequestToSend` value, it is probably for nonstandard operations.

If your device does not use hardware handshaking in the standard way, and you need to manually configure `RequestToSend`, then you should configure the `FlowControl` property to `none`. Otherwise, the `RequestToSend` value that you specify might not be honored. Refer to your device documentation to determine its specific pin behavior.

You can return the value of the CTS pin with the `PinStatus` property. Handshaking is described in “Controlling the Flow of Data: Handshaking” on page 10-61.

Characteristics

Read only	Never
Data type	String

Values

<code>{on}</code>	The RTS pin is asserted.
<code>off</code>	The RTS pin is unasserted.

See Also **Properties**
`FlowControl`, `PinStatus`

Purpose Indicate if the serial port object is connected to the device

Description Status can be open or closed. If Status is closed, the serial port object is not connected to the device. If Status is open, the serial port object is connected to the device.

Before you can write or read data, you must connect the serial port object to the device with the `fopen` function. You use the `fclose` function to disconnect a serial port object from the device.

Characteristics Read only Always

Data type String

Values {closed} The serial port object is not connected to the device.

open The serial port object is connected to the device.

See Also **Functions**
`fclose`, `fopen`

StopBits

Purpose Specify the number of bits used to indicate the end of a byte

Description You can configure StopBits to be 1, 1.5, or 2. If StopBits is 1, one stop bit is used to indicate the end of data transmission. If StopBits is 2, two stop bits are used to indicate the end of data transmission. If StopBits is 1.5, the stop bit is transferred for 150% of the normal time used to transfer one bit.

Note Both the computer and the peripheral device must be configured to transmit the same the number of stop bits.

In addition to the stop bits, the serial data format consists of a start bit, between five and eight data bits, and possibly a parity bit. You specify the number of data bits with the DataBits property, and the type of parity checking with the Parity property.

Characteristics

Read only	Never
Data type	Double

Values

{1}	One stop bit is transmitted to indicate the end of a byte.
1.5	The stop bit is transferred for 150% of the normal time used to transfer one bit.
2	Two stop bits are transmitted to indicate the end of a byte.

See Also **Properties**
DataBits, Parity

Purpose	Specify a label to associate with a serial port object				
Description	<p>You configure Tag to be a string value that uniquely identifies a serial port object.</p> <p>Tag is particularly useful when constructing programs that would otherwise need to define the serial port object as a global variable, or pass the object as an argument between callback routines.</p> <p>You can return the serial port object with the <code>instrfind</code> function by specifying the Tag property value.</p>				
Characteristics	<table><tr><td>Read only</td><td>Never</td></tr><tr><td>Data type</td><td>String</td></tr></table>	Read only	Never	Data type	String
Read only	Never				
Data type	String				
Values	The default value is an empty string.				
Example	<p>Suppose you create a serial port object associated with the serial port COM1.</p> <pre>s = serial('COM1'); fopen(s)</pre> <p>You can assign <code>s</code> a unique label using Tag.</p> <pre>set(s, 'Tag', 'MySerialObj')</pre> <p>You can access <code>s</code> in the MATLAB workspace or in an M-file using the <code>instrfind</code> function and the Tag property value.</p> <pre>s1 = instrfind('Tag', 'MySerialObj');</pre>				
See Also	Functions <code>instrfind</code>				

Terminator

Purpose Specify the terminator character

Description You can configure Terminator to an integer value ranging from 0 to 127, which represents the ASCII code for the character, or you can configure Terminator to the ASCII character. For example, to configure Terminator to a carriage return, you specify the value to be CR or 13. To configure Terminator to a line feed, you specify the value to be LF or 10. You can also set Terminator to CR/LF or LF/CR. If Terminator is CR/LF, the terminator is a carriage return followed by a line feed. If Terminator is LF/CR, the terminator is a line feed followed by a carriage return. Note that there are no integer equivalents for these two values. Additionally, you can set Terminator to a 1-by-2 cell array. The first element of the cell is the read terminator and the second element of the cell array is the write terminator

When performing a write operation using the `fprintf` function, all occurrences of `\n` are replaced with the Terminator property value. Note that `%s\n` is the default format for `fprintf`. A read operation with `fgetl`, `fgets`, or `fscanf` completes when the Terminator value is read. The terminator is ignored for binary operations.

You can also use the terminator to generate a bytes-available event when the `BytesAvailableFcnMode` is set to terminator.

Characteristics

Read only	Never
Data type	String

Values An integer value ranging from 0 to 127, or the equivalent ASCII character. CR/LF and LF/CR are also accepted values. You specify different read and write terminators as a 1-by-2 cell array.

See Also

Functions
`fgetl`, `fgets`, `fprintf`, `fscanf`

Properties
`BytesAvailableFcnMode`

Purpose Specify the waiting time to complete a read or write operation

Description You configure `Timeout` to be the maximum time (in seconds) to wait to complete a read or write operation.

If a timeout occurs, then the read or write operation aborts. Additionally, if a timeout occurs during an asynchronous read or write operation, then:

- An error event is generated.
- The M-file callback function specified for `ErrorFcn` is executed.

Characteristics

Read only	Never
Data type	Double

Values The default value is 10 seconds.

See Also **Properties**
`ErrorFcn`

TimerFcn

Purpose Specify the M-file callback function to execute when a predefined period of time passes.

Description You configure `TimerFcn` to execute an M-file callback function when a timer event occurs. A timer event occurs when the time specified by the `TimerPeriod` property passes. Time is measured relative to when the serial port object is connected to the device with `fopen`.

Note A timer event can be generated at any time during the serial port session.

If the `RecordStatus` property value is on, and a timer event occurs, the record file records this information:

- The event type as `Timer`
- The time the event occurred using the format `day-month-year hour:minute:second:millisecond`

Some timer events might not be processed if your system is significantly slowed or if the `TimerPeriod` value is too small.

Refer to “Creating and Executing Callback Functions” on page 10-54 to learn how to create a callback function.

Characteristics

Read only	Never
Data type	Callback function

Values The default value is an empty string.

See Also

Functions
`fopen`, `record`

Properties
`RecordStatus`, `TimerPeriod`

Purpose Specify the period of time between timer events

Description `TimerPeriod` specifies the time, in seconds, that must pass before the callback function specified for `TimerFcn` is called. Time is measured relative to when the serial port object is connected to the device with `fopen`.

Some timer events might not be processed if your system is significantly slowed or if the `TimerPeriod` value is too small.

Characteristics

Read only	Never
Data type	Callback function

Values The default value is 1 second. The minimum value is 0.01 second.

See Also

Functions
`fopen`

Properties
`TimerFcn`

TransferStatus

Purpose Indicate if an asynchronous read or write operation is in progress

Description TransferStatus can be `idle`, `read`, `write`, or `read&write`. If TransferStatus is `idle`, then no asynchronous read or write operations are in progress. If TransferStatus is `read`, then an asynchronous read operation is in progress. If TransferStatus is `write`, then an asynchronous write operation is in progress. If TransferStatus is `read&write`, then both an asynchronous read and an asynchronous write operation are in progress.

You can write data asynchronously using the `fprintf` or `fwrite` functions. You can read data asynchronously using the `readasync` function, or by configuring the `ReadAsyncMode` property to `continuous`. While `readasync` is executing, TransferStatus might indicate that data is being read even though data is not filling the input buffer. If `ReadAsyncMode` is `continuous`, TransferStatus indicates that data is being read only when data is actually filling the input buffer.

You can execute an asynchronous read and an asynchronous write operation simultaneously because serial ports have separate read and write pins. Refer to “Writing and Reading Data” on page 10-30 for more information about synchronous and asynchronous read and write operations.

Characteristics	Read only	Always
	Data type	String

Values	<code>{idle}</code>	No asynchronous operations are in progress.
	<code>read</code>	An asynchronous read operation is in progress.
	<code>write</code>	An asynchronous write operation is in progress.
	<code>read&write</code>	Asynchronous read and write operations are in progress.

See Also **Functions**
`fprintf`, `fwrite`, `readasync`

Properties
`ReadAsyncMode`

Purpose Indicate the object type

Description Type indicates the type of the object. Type is automatically defined after the serial port object is created with the `serial` function. The Type value is always `serial`.

Characteristics

Read only	Always
Data type	String

Values Type is always `serial`. This value is automatically defined when the serial port object is created.

Example Suppose you create a serial port object associated with the serial port COM1.

```
s = serial('COM1');
```

The value of the Type property is `serial`, which is the object class.

```
s.Type
ans =
serial
```

You can also display the object class with the `whos` command.

```
Name      Size      Bytes  Class
s          1x1          644  serial object
```

```
Grand total is 18 elements using 644 bytes
```

See Also **Functions**
`serial`

UserData

Purpose Specify data that you want to associate with a serial port object

Description You configure UserData to store data that you want to associate with a serial port object. The object does not use this data directly, but you can access it using the get function or the dot notation.

Characteristics

Read only	Never
Data type	Any type

Values The default value is an empty vector.

Example Suppose you create the serial port object associated with the serial port COM1.

```
s = serial('COM1');
```

You can associate data with `s` by storing it in `UserData`.

```
coeff.a = 1.0;  
coeff.b = -1.25;  
s.UserData = coeff;
```

Purpose	Indicate the total number of values read from the device				
Description	<p>ValuesReceived indicates the total number of values read from the device. The value is updated after each successful read operation, and is set to 0 after the fopen function is issued. If the terminator is read from the device, then this value is reflected by ValuesReceived.</p> <p>If you are reading data asynchronously, use the BytesAvailable property to return the number of bytes currently available in the input buffer.</p> <p>When performing a read operation, the received data is represented by values rather than bytes. A value consists of one or more bytes. For example, one uint32 value consists of four bytes. Refer to “Bytes Versus Values” on page 10-12 for more information about bytes and values.</p>				
Characteristics	<table><tr><td>Read only</td><td>Always</td></tr><tr><td>Data type</td><td>Double</td></tr></table>	Read only	Always	Data type	Double
Read only	Always				
Data type	Double				
Values	The default value is 0.				
Example	<p>Suppose you create a serial port object associated with the serial port COM1.</p> <pre>s = serial('COM1'); fopen(s)</pre> <p>If you write the RS232? command, and then read back the response using fscanf, ValuesReceived is 17 because the instrument is configured to send the LF terminator.</p> <pre>fprintf(s, 'RS232?') out = fscanf(s) out = 9600;0;0;NONE;LF s.ValuesReceived ans = 17</pre>				
See Also	Functions fopen				

ValuesReceived

Properties

BytesAvailable

Purpose	Indicate the total number of values written to the device				
Description	<p>ValuesSent indicates the total number of values written to the device. The value is updated after each successful write operation, and is set to 0 after the fopen function is issued. If you are writing the terminator, then ValuesSent reflects this value.</p> <p>If you are writing data asynchronously, use the BytesToOutput property to return the number of bytes currently in the output buffer.</p> <p>When performing a write operation, the transmitted data is represented by values rather than bytes. A value consists of one or more bytes. For example, one uint32 value consists of four bytes. Refer to “Bytes Versus Values” on page 10-12 for more information about bytes and values.</p>				
Characteristics	<table><tr><td>Read only</td><td>Always</td></tr><tr><td>Data type</td><td>Double</td></tr></table>	Read only	Always	Data type	Double
Read only	Always				
Data type	Double				
Values	The default value is 0.				
Example	<p>Suppose you create a serial port object associated with the serial port COM1.</p> <pre>s = serial('COM1'); fopen(s)</pre> <p>If you write the *IDN? command using the fprintf function, then ValuesSent is 6 because the default data format is %s\n, and the terminator was written.</p> <pre>fprintf(s, '*IDN?') s.ValuesSent ans = 6</pre>				
See Also	Functions fopen Properties BytesToOutput				

Symbols

`%val` 5-4, 5-7

allocating memory 5-24

DIGITAL Visual Fortran 5-7

A

API

access methods 3-3

memory management 3-33

argument checking 4-8

argument passing, from Java methods

data conversion 7-59

built-in data types 7-60

conversions you can perform 7-60

Java objects 7-60

argument passing, to Java methods

data conversion 7-49

built-in arrays 7-51

built-in data types 7-51

Java object arrays 7-55

Java object cell arrays 7-56

Java objects 7-53

objects of Object class 7-54

string arrays 7-53

string data types 7-52

effect of dimension on 7-56

argument type, Java

effect on method dispatching 7-57

array access methods 5-6

mat 1-2

arrays

cell 3-6

empty 3-6

hybrid 4-39

MATLAB 3-4

multidimensional 3-6

persistent 4-38

serial port object 9-26

sparse 4-29

temporary 4-37, 5-35

arrays, Java

accessing elements of 7-38

assigning

the empty matrix 7-44

values to 7-41

with single subscripts 7-42

comparison with MATLAB arrays 7-32

concatenation of 7-45

creating a copy 7-47

creating a reference 7-46

creating in MATLAB 7-36

creating with `javaArray` 7-36

dimensionality of 7-32

dimensions 7-35

indexing 7-34

with colon operator 7-39

with single subscripts 7-38, 7-40

linear arrays 7-43

passed by reference 7-52

representing in MATLAB 7-32

sizing 7-34

subscripted deletion 7-44

using the end subscript 7-41

ASCII file mode 1-5

ASCII flat file 1-3

automation

client 8-60

controller 8-7, 8-66

server 8-66

B

- BaudRate 9-76
- bcc53engmatopts.bat 3-16
- bcc53opts.bat 3-15
- bcc54engmatopts.bat 3-16
- bcc54opts.bat 3-15
- bcc55engmatopts.bat 3-16
- bcc55opts.bat 3-15
- bccengmatopts.bat 3-16
- bccopts.bat 3-15
- binary data
 - reading from a device 9-42
 - writing to a device 9-36
- binary file mode 1-5
- BLAS and LAPACK functions 4-45
 - building MEX files for 4-49, 4-52
 - example of 4-51
 - handling complex numbers 4-47
 - passing arguments 4-46
 - specifying the function name 4-46
- BreakInterruptFcn 9-77
- BSTR 8-72
- buffer
 - input, serial port object 9-38
 - output, serial port object 9-32
- ByteOrder 9-78
- BytesAvailable 9-79
- BytesAvailableFcn 9-80
- BytesAvailableFcnCount 9-83
- BytesAvailableFcnMode 9-84

C

- C example
 - convec.c 4-20
 - doubleelem.c 4-23
 - findnz.c 4-25

- fulltosparse.c 4-29
- phonebook.c 4-16
- revord.c 4-10
- sincall.c 4-33
- timestwo.c 4-7
- timestwoalt.c 4-9
- xtimesy.c 4-14

C language

- data types 3-7
- debugging 4-53
- MEX-files 4-1

C language example

- basic 4-7
- calling MATLAB functions 4-33
- calling user-defined functions 4-33
- handling 8-, 16-, 32-bit data 4-23
- handling arrays 4-25
- handling complex data 4-20
- handling sparse arrays 4-29
- passing multiple values 4-13
- persistent array 4-38
- strings 4-10

callback

- serial port object 9-49
 - functions 9-53
 - properties 9-49

caller workspace 4-37

cat

- using with Java arrays 7-45
- using with Java objects 7-14

cell

- using with Java objects 7-63

cell arrays 3-6, 4-16

- converting from Java object 7-63

char

- overloading toChar in Java 7-61

- character encoding
 - default character set 1-8
 - lossless data conversion 1-8
 - Unicode 1-8
- class
 - using in Java 7-20
- classes, Java 7-4
 - built-in 7-4
 - defining 7-4
 - identifying using which 7-27
 - importing 7-10
 - loading into workspace 7-9
 - making available to MATLAB 7-7
 - sources for 7-4
 - third-party 7-4
 - user-defined 7-4
- classpath.txt
 - finding and editing 7-6
 - using with Java archive files 7-8
 - using with Java classes 7-7
 - using with Java packages 7-8
- client (DDE) 8-75
- collections 8-62
- colon
 - using in Java array access 7-39
 - using in Java array assignment 7-43
- COM
 - automation server 8-66
 - collections 8-62
 - concepts 8-2
 - controller 8-66
 - Count property 8-62
 - event handler function 8-52
 - Item method 8-62
 - launching server 8-73
 - limitations of MATLAB support 8-65
 - MATLAB as automation client 8-60
 - ProgID 8-3, 8-16, 8-17
 - server 8-66
 - use in the MATLAB Engine 6-4
- commands. *See* individual commands.
- Compaq Visual Fortran compiler
 - debugging 5-37
- compiler
 - changing on UNIX 3-10
 - debugging
 - Compaq Visual Fortran 5-37
 - Microsoft 4-54
 - Watcom 4-55
 - preconfigured options file 3-15–3-17
 - selecting on Windows 3-12
 - supported 3-9
- compiling
 - engine application
 - UNIX 6-17–6-18
 - Windows 6-19
 - MAT-file application
 - UNIX 1-31
 - Windows 1-33
- complex data
 - in Fortran 5-21
- comopts.bat 3-21
- computational routine 4-2, 5-2
- concatenation
 - of Java arrays 7-45
 - of Java objects 7-14
- configuration 3-9
 - problems 3-31
 - UNIX 3-10
 - Windows 3-12, 3-14
- control pins
 - serial port object, using 9-57
- convec.c 4-20
- convec.f 5-21

conversation (DDE) 8-75
conversion, data
 in Java method arguments 7-49
copying a Java array 7-47
Count property 8-62

D

data access
 within Java objects 7-18
data bits 9-13
data format
 serial port 9-11
data storage 3-4
data type 4-6
 C language 3-7
 cell arrays 3-6
 checking 4-8
 complex double-precision nonsparse matrix
 3-5
 empty arrays 3-6
 Fortran language 3-7
 MAT-file 1-5
 MATLAB 3-7
 MATLAB string 3-7
 multidimensional arrays 3-6
 numeric matrix 3-5
 objects 3-6
 sparse arrays 4-29
 sparse matrices 3-7
 structures 3-6
data, MATLAB 3-4
 exporting from 1-3–1-4
 importing to 1-2–1-3
DataBits 9-86
DataTerminalReady 9-87
DataToOutput 9-85

dblmat.f 5-24
dbmex 5-36
DCE 9-5
DCOM (distributed component object model) 8-74
 using MATLAB as a server 8-74
DDE (dynamic data exchange) 8-75
 accessing MATLAB as server 8-77
 advisory links 8-84
 client 8-75
 conversation 8-75
 hot link 8-84
 item 8-76
 MATLAB
 requesting data from 8-80
 sending commands to 8-79
 sending data to 8-81
 using as client 8-83
 name hierarchy 8-78
 notifying when data changes 8-84
 server 8-75
 service name 8-76
 topic 8-76, 8-78–8-82
 engine 8-79
 system 8-78
 warm link 8-84
 Windows clipboard formats 8-76–8-77
ddeadv 8-83
ddeexec 8-83
ddeinit 8-83
ddepoke 8-83
ddereq 8-83
ddeterm 8-83
ddeunadv 8-83
debugging C language MEX-files 4-53
 UNIX 4-53
 Windows 4-54

- debugging Fortran language MEX-files
 - UNIX 5-36
 - Windows 5-37
 - df50engmatopts.bat 3-17
 - df50opts.bat 3-16
 - df60engmatopts.bat 3-17
 - df61opts.bat 3-16
 - df66opts.bat 3-16
 - diary 1-3
 - diary file 1-3
 - DIGITAL Visual Fortran compiler
 - debugging 5-37
 - directory
 - eng_mat 3-44
 - mex 3-43
 - mx 3-43
 - refbook 3-43
 - directory organization
 - MAT-file application 1-9
 - Microsoft Windows 3-41
 - UNIX 3-38
 - directory path
 - convention 3-7
 - display
 - serial port object 9-25
 - display function
 - overloading toString in Java 7-28
 - distributed component object model. *See* DCOM.
 - dll extension 3-2
 - dll libraries
 - data conversion 2-11
 - enumerated types 2-15
 - primitive types 2-11
 - reference pointers 2-25
 - references 2-21
 - strings 2-14
 - structures 2-15
 - library functions
 - getting information about 2-4
 - invoking functions 2-7
 - passing arguments 2-8
 - general rules 2-9
 - libstruct objects 2-18
 - references 2-10
 - structures 2-17
 - loading the library 2-3
 - MATLAB interface to 2-1
 - unloading the library 2-3
 - DLLs 3-9
 - locating 3-28
 - documenting MEX-file 4-36, 5-34
 - double
 - overloading toDouble in Java 7-61
 - doubleelem.c 4-23
 - DTE 9-5
 - dynamic data exchange. *See* DDE.
 - dynamic memory allocation
 - in Fortran 5-24
 - mxMalloc 4-11
 - dynamically linked subroutines 3-2
- ## E
- empty arrays 3-6
 - empty matrix
 - conversion to Java NULL 7-57
 - in Java array assignment 7-44
 - empty string
 - conversion to Java object 7-57
 - end
 - use with Java arrays 7-41
 - eng_mat directory 3-44, 6-5
 - engClose 6-2, 6-3
 - engdemo.c 6-5

- engEvalString 6-3
- engGetVariable 6-2, 6-3
- engGetVisible 6-3
- engine
 - compiling 6-16
 - linking 6-16
 - UNIX 6-17
 - windows 6-19
- engine application
 - Windows 6-19
- engine example
 - calling MATLAB
 - from C program 6-5
 - from Fortran program 6-10
- engine functions 6-2–6-3
- engine library 6-1
 - communicating with MATLAB
 - UNIX 6-4
 - Windows 6-4
- engOpen 6-2, 6-3
- engOpenSingleUse 6-3
- engopts.sh 3-17
- engOutputBuffer 6-3
- engPutVariable 6-3
- engSetVisible 6-3
- engwindemo.c 1-25, 6-5
- ErrorFcn 9-88
- event handler
 - function 8-52
 - writing 8-52
- events
 - serial port object 9-49
 - storing information 9-51
 - types 9-49
- examples, Java programming
 - communicating through a serial port 7-71
 - creating and using a phone book 7-76

- finding an internet protocol address 7-69
- reading a URL 7-66
- exception
 - floating-point 1-30, 6-16
- exceptions, Java
 - handling 7-30
- explore example 3-7
- extension
 - MEX-file 3-2

F

- f option 3-15
- fengdemo.f 6-10
- fieldnames
 - using with Java objects 7-17
- Figure
 - Methods of library libmx 2-6
- file mode
 - ASCII 1-5
 - binary 1-5
- files
 - flat 1-3
 - linking multiple 4-36, 5-34
- findnz.c 4-25
- floating-point exceptions
 - Borland C++ Compiler on Windows 1-31, 6-17
 - engine applications 6-16
 - masking 1-30, 6-16
 - MAT-file applications 1-30
- FlowControlHardware 9-89
- fopen 1-3, 1-4
- Fortran
 - case in 5-5
 - data types 3-7

- pointers
 - concept 5-4, 5-15
 - declaring 5-4
- Fortran examples
 - convec.f 5-21
 - dblmat.f 5-24
 - fulltoparse.f 5-27
 - matsq.f 5-16
 - passstr.f 5-14
 - revord.f 5-11
 - sincall.f 5-30
 - timestwo.f 5-9
 - xtimesy.f 5-18
- Fortran language examples
 - calling MATLAB functions 5-30
 - handling complex data 5-21
 - handling sparse matrices 5-26
 - passing arrays of strings 5-13
 - passing matrices 5-15
 - passing multiple values 5-18
 - passing scalar 4-7, 5-9
 - passing strings 5-11
- Fortran language MEX-files 5-2
 - components 5-2
- fread 1-3
- fulltoparse.c 4-29
- fulltoparse.f 5-27
- function handles
 - serial port object callback 9-53
- fwrite 1-4

G

- g option 4-53
- gateway routine 4-2, 5-2, 5-4
 - accessing mxArray data 4-2
- gccopts.sh 3-17

H

- handshaking
 - serial port object 9-60
- help 4-36, 5-34
- help files 4-36, 5-34
- hybrid array
 - persistent 4-40
 - temporary 4-39
- hybrid arrays 4-39

I

- IDE
 - building MEX-files 3-18
- IEEE routines 3-3
- import
 - using with Java classes 7-10
- include directory 1-9
- indexing Java arrays
 - using single colon subscripting 7-40
 - using single subscripting 7-38
- InputBufferSize 9-90
- internet protocol address
 - Java example 7-69
- ir 3-7, 4-29, 5-26
- isa
 - using with Java objects 7-20
- isjava
 - using with Java objects 7-20
- Item method 8-62

J

- Java
 - API class packages 7-2
 - archive (JAR) files 7-8
 - development kit 7-5

- Java Virtual Machine (JVM) 7-2
 - packages 7-8
- Java, MATLAB interface to
 - arguments passed to Java methods 7-49
 - arguments returned from Java methods 7-59
 - arrays, working with 7-31
 - benefits of 7-2
 - classes, using 7-4
 - examples 7-65
 - methods, invoking 7-21
 - objects, creating and using 7-12
 - overview 7-2
- javaArray function 7-36
- jc 3-7, 4-29, 5-26

L

- LAPACK and BLAS functions 4-45
 - building MEX files for 4-49, 4-52
 - example of 4-51
 - handling complex numbers 4-47
 - passing arguments 4-46
 - specifying the function name 4-46
- lccengmatopts.bat 3-16
- lccopts.bat 3-15
- library path
 - setting on UNIX 1-31, 6-17
- linking DLLs to MEX-files 3-26
- linking multiple files 4-36, 5-34
- load 1-3, 1-5
 - using with Java objects 7-16
- loading
 - serial port objects 9-69
- locating DLLs 3-28

M

- mat.h 1-9
- matClose 1-6, 1-7
- matDeleteVariable 1-6, 1-7
- matdemo1.f 1-21
- matdemo2.f 1-26
- MAT-file
 - C language
 - reading 1-17
 - compiling 1-30
 - data types 1-5
 - examples 1-10
 - Fortran language
 - creating 1-21
 - reading 1-26
 - linking 1-30
 - subroutines 1-5
 - UNIX libraries 1-10
 - using 1-2
 - Windows libraries 1-10
- MAT-file application
 - UNIX 1-31
 - Windows 1-33
- MAT-file example
 - creating
 - C language 1-12
 - Fortran language 1-21
 - reading
 - C language 1-17
 - Fortran language 1-26
- MAT-functions 1-6--??
- matGetDir 1-6, 1-7
- matGetFp 1-6
- matGetNextVariable 1-6, 1-7
- matGetNextVariableInfo 1-6, 1-7
- matGetVariable 1-6, 1-7
- matGetVariableInfo 1-6, 1-7

MATLAB

- arrays 3-4
- as DCOM server client 8-65
- data 3-4
- data file format 1-2
- data storage 3-4
- data type 3-7
- engine 6-1
- exporting data 1-2–1-4
- importing data 1-2–1-3
- MAT-file 1-5
 - reading arrays from 1-5
 - saving arrays to 1-5
- moving data between platforms 1-4–1-5
- stand-alone applications 1-2
- string 3-6
- using as a computation engine 6-1
- variables 3-4

matOpen 1-6, 1-7

matopts.sh 3-17

matPutArray 1-6, 1-7

matPutArrayAsGlobal 1-6, 1-7

matrix

- complex double-precision nonsparse 3-5
- numeric 3-5
- sparse 3-7, 5-26

matrix.h 1-9

matsq.f 5-16

memory

- allocation 4-11
- leak 3-36, 4-38
- temporary 5-35

memory management 3-33, 4-37, 5-35

- API 3-33
- compatibility 3-33
- routines 3-3
- special considerations 4-37

methods

- using with Java methods 7-26

methods, Java

- calling syntax 7-21
- converting input arguments 7-49
- displaying 7-26
- displaying information about 7-24
- finding the defining class 7-27
- overloading 7-57
- passing data to 7-49
- static 7-23
- undefined 7-29

methodsview 7-24

- output fields 7-26

mex

- <ENV_VAR>#<val> 3-20
- g 4-53, 5-36

mex build script 3-18, 4-9

- default options file, UNIX 3-20
- default options file, Windows 3-21
- switches 3-19

- <name>#<def> 3-20
- <name>=<def> 3-20
- @<rsp_file> 3-19
- argcheck 3-19
- c 3-19
- D<name>[#<def>] 3-19
- f <file> 3-19
- fortran 4-37, 5-34
- g 3-19
- h[elp] 3-19
- I<pathname> 3-19
- inline 3-19
- l<file> 3-19
- L<pathname> 3-19
- O 3-20
- outdir <name> 3-20

- output <name> 3-20
- setup 3-12, 3-20
- U<name> 3-20
- v 3-20
- V5 3-20
- mex directory 3-43
- mex.bat 4-9
- mex.m 4-9
- mex.sh 4-9
- mexAtExit 4-38
 - register a function 4-38
- mexCallMATLAB 4-33, 4-35, 4-37, 5-30, 5-32, 5-33
- mexErrMsgTxt 4-37, 5-6
- mexEvalString 4-37, 5-34
- MEX-file 3-2
 - advanced topics 4-36
 - Fortran 5-34
 - applications of 3-2
 - arguments 4-4
 - C language 4-1
 - calling 3-3
 - compiling 4-9
 - Microsoft Visual C++ 3-26
 - UNIX 3-10, 3-22–3-24
 - Windows 3-14, 3-24–3-27
 - components 4-2
 - computation error 3-33
 - configuration problem 3-31
 - creating C language 4-2, 4-9
 - creating Fortran language 5-2
 - custom building 3-18
 - debugging C language 4-53
 - debugging Fortran language 5-36
 - DLL linking 3-26
 - documenting 4-36, 5-34
 - dynamically allocated memory 4-37
 - examples 4-6, 5-8
 - extensions 3-2
 - load error 3-31
 - overview 3-2
 - passing cell arrays 4-16
 - passing structures 4-16
 - problems 3-30–3-33
 - segmentation error 3-32
 - syntax errors 3-31
 - temporary array 4-37
 - using 3-2
 - versioning 3-26
- mexFunction 4-2, 5-2, 5-4
 - altered name 5-37
 - parameters 4-2, 5-2
- mexGetMatrix 5-34
- mexGetVariable 4-37
- mexglx extension 3-2
- mexhpux extension 3-2
- mexmac extension 3-2
- mexMakeArrayPersistent 4-38
- mexMakeMemoryPersistent 4-38
- mexopts.bat 3-21
- mexopts.sh 3-17
- mexPutMatrix 5-34
- mexPutVariable 4-37
- mexSetTrapFlag 4-37
- mexsol extension 3-2
- mexversion.rc 3-26
- M-file
 - creating data 1-3
- Microsoft compiler
 - debugging 4-54
- Microsoft Windows
 - directory organization 3-41
- msvc50engmatopts.bat 3-16
- msvc50opts.bat 3-15
- msvc60engmatopts.bat 3-16

- msvc60opts.bat 3-16
- multidimensional arrays 3-6
- mx directory 3-43
- mxArray 3-4, 5-6
 - accessing data 4-2
 - contents 3-4
 - improperly destroying 3-34
 - ir 3-7
 - jc 3-7
 - nzmax 3-7
 - pi 3-7
 - pr 3-7
 - temporary with improper data 3-35
 - type 3-4
- mxCalloc 4-11, 4-37, 5-6
- mxCopyComplex16ToPtr 5-21
- mxCopyPtrToComplex16 5-21
- mxCopyPtrToReal8 5-7, 5-18
- mxCreateFull 5-6, 5-16
- mxCreateNumericArray 4-23
- mxCreateSparse 5-6
- mxCreateString 4-12, 5-6
- mxDestroyArray 3-33, 4-39, 5-35
- mxFree 3-34
- mxGetCell 4-16
- mxGetData 4-16, 4-23, 4-25
- mxGetField 4-16
- mxGetImagData 4-23, 4-25
- mxGetPi 4-20, 5-15
- mxGetPr 4-16, 4-20, 5-15
- mxGetScalar 4-9, 4-16
- mxMalloc 4-11, 4-37
- mxRealloc 4-11, 4-37
- mxSetCell 3-35, 4-39
- mxSetData 3-36, 3-37, 4-39
- mxSetField 3-35
- mxSetImagData 3-36, 3-37

- mxSetIr 3-37
- mxSetJc 3-37
- mxSetPi 3-36, 3-37
- mxSetPr 3-36, 4-39
- mxUNKNOWN_CLASS 4-35, 5-33

N

- Name
 - serial port property 9-91
- ndims
 - using with Java arrays 7-35
- nlhs 4-2, 4-4, 5-2, 5-5
- nrhs 4-2, 4-4, 5-2, 5-5
- null modem cable 9-6
- numeric matrix 3-5
- nzmax 3-7, 5-26

O

- objects 3-6
 - serial port 9-24
- objects, Java
 - accessing data within 7-18
 - concatenating 7-14
 - constructing 7-12
 - converting to MATLAB cell array 7-63
 - converting to MATLAB structures 7-62
 - identifying fieldnames 7-17
 - information about 7-20
 - class name 7-20
 - class type 7-20
 - passing by reference 7-14
 - saving and loading 7-16
- options file
 - creating new 3-18
 - modifying 3-18

- preconfigured 3-15
 - specifying 3-15
 - when to specify 3-15
- OutputBufferSize 9-92
- OutputEmptyFcn 9-93
- overloading Java methods 7-57

P

- Parity 9-94
- parity bit 9-14
- passing data to Java methods 7-49
- passstr.f 5-14
- persistent arrays
 - exempting from cleanup 4-38
- phonebook.c 4-16
- pi 3-5
- PinStatus 9-95
- PinStatusFcn 9-96
- plhs 4-2, 4-4, 5-2, 5-5
- pointer 5-4
 - Fortran language MEX-file 5-15
- Port 9-97
- pr 3-5
- prhs 4-2, 4-4, 5-2, 5-5
- properties
 - serial port object 9-72
- protocol
 - DCOM 8-74

R

- read/write failures, checking for 1-12
- ReadAsyncMode 9-98
- reading
 - binary data from a device 9-42
 - text data from a device 9-40

- record file
 - serial port object
 - creating multiple files 9-64
 - filename 9-64
 - format 9-65
- RecordDetail 9-100
- RecordMode 9-101
- RecordName 9-103
- RecordStatus 9-104
- refbook directory 3-43
- references
 - to Java arrays 7-46
- RequestToSend 9-105
- revord.c 4-10
- revord.f 5-11
- routine
 - computational 4-2
 - gateway 4-2, 5-2
 - mex 3-3
 - mx 3-3
- RS-232 standard 9-4

S

- save 1-4, 1-5
 - using with Java objects 7-16
- saving
 - serial port objects 9-69
- serial port
 - data format 9-11
 - devices,connecting 9-5
 - object creation 9-24
 - RS-232 standard 9-4
 - session 9-19
 - signal and pin assignments 9-6

- serial port object
 - array creation 9-26
 - callback properties 9-49
 - configuring communications 9-28
 - connecting to device 9-27
 - disconnecting 9-70
 - display 9-25
 - event types 9-49
 - handshaking 9-60
 - input buffer 9-38
 - output buffer 9-32
 - properties 9-72
 - reading binary data 9-42
 - reading text data 9-40
 - recording information to disk 9-63
 - using control pins 9-57
 - using events and callbacks 9-49
 - writing and reading data 9-29
 - writing binary data 9-36
 - writing text data 9-34
- serializable interface 7-16
- service name 8-75, 8-76
- session
 - serial port 9-19
- shared libraries
 - data conversion 2-11
 - enumerated types 2-15
 - primitive types 2-11
 - reference pointers 2-25
 - references 2-21
 - strings 2-14
 - structures 2-15
 - library functions
 - getting information about 2-4
 - invoking functions 2-7
 - passing arguments 2-8
 - general rules 2-9
 - libstruct objects 2-18
 - references 2-10
 - structures 2-17
 - loading the library 2-3
 - MATLAB interface to 2-1
 - unloading the library 2-3
- shared libraries directory
 - UNIX 1-10
 - Windows 1-10
- sharing character data 1-8
- sincall.c 4-33
- sincall.f 5-30
- size
 - using with Java arrays 7-34
- sparse arrays 4-29
- sparse matrices 3-7
- start bit 9-13
- static data, Java
 - accessing 7-19
 - assigning 7-19
- static methods, Java 7-23
- Status 9-106
- stop bit 9-13
- StopBits 9-107
- storing data 3-4
- string 3-6
- struct
 - using with Java objects 7-62
- structures 4-16
- structures, MATLAB 3-6
 - converting from Java object 7-62
- subroutines
 - dynamically linked 3-2
- system configuration 3-9

T

Tag

- serial port property 9-108

temporary arrays 4-37

- automatic cleanup 4-37

- destroying 3-37

temporary memory

- cleaning up 3-37

Terminator 9-109

text data

- reading from a device 9-40

- writing to a device 9-34

Timeout 9-110

TimerFcn 9-111

TimerPeriod 9-112

timestwo.c 4-7

timestwo.f 5-9

timestwoalt.c 4-9

TransferStatus 9-113

troubleshooting

- MEX-file creation 3-30

Type

- serial port property 9-114

U

UNIX

- directory organization 3-38

URL

- Java example 7-66

UserData

- serial port property 9-115

V

ValuesReceived 9-116

ValuesSent 9-118

variable scope 4-37

variables 3-4

versioning MEX-files 3-26

Visual Basic

- MATLAB DDE server example 8-81

W

wat11copts.bat 3-16

wat11engmatopts.bat 3-17

Watcom compiler

- debugging 4-55

watcopts.bat 3-16

watengmatopts.bat 3-17

which

- using with Java methods 7-27

Windows

- automation 8-66

- COM 8-66

- directory organization 3-41

- mex -setup 3-12

- selecting compiler 3-12

Windows clipboard format

- Metafile pict 8-77

- text 8-76

- XLTable 8-77

workspace

- caller 4-37, 5-34

- MEX-file function 4-37, 5-34

write/read failures, checking for 1-12

writing

- binary data to a device 9-36

- text data to a device 9-34

writing event handlers 8-52

X

`xtimesy.c` 4-14

`xtimesy.f` 5-18

Y

`yprime.c` 3-10, 3-14

`yprimef.F` 3-10

`yprimef.f` 3-14

`yprimefg.F` 3-10

`yprimefg.f` 3-14

